



HAWK ENTERPRISES OF ELKHART, INC

2014&2814

TigerHawk Owner's Manual



2014 TIGERHAWK



2814 TIGERHAWK

Hawk Enterprises
52744 Park Six Court
Elkhart, IN 46514

Phone: 574-294-1910
Toll Free: 888-289-4295

Fax: 574-970-0289
Toll Free 866-429-5329

Service Information	2
Machine Specifications	3
Features	3
Important Safety Instructions.....	4
Grounding Instructions	5-6
Operations	7
Guidelines For Operations	7
Controls.....	7
Adjustments.....	8
Cord Storage	8
Clean Up And Storage	8
TigerHawk Assemblies	9-14
Optional Accessories.....	15
Limited Warranty	Back Cover

SERVICE INFORMATION

To obtain consistent performance over the life of your equipment, read through these instructions and save them for future reference. If you require service, contact the dealer from which the machine was purchased or an authorized service station.

Always refer to your limited Warranty for complete service information.

The model, type, and serial number are indicated on the data plate on the side of the handle. From prompt and complete service, refer to these numbers when inquiring about service.

SERIAL NO.	MODEL		
VOLTS	PHASE	HZ	
MOTOR	AMPS	H.P.	

Write the model and serial number of your unit in the space provided. Refer to the data plate on unit.	
SERIAL #	MODEL #
Retain this owners manual for future reference.	

Model #	TH-2014	TH-2814
Part #	F-TIGER2014	F-TIGER2814
Pad Size	20" X 14"	28" X 14"
Pad Driver Type	Combination Pad Holder/Diamond Pad Driver	Combination Pad Holder/Diamond Pad Driver
Power Source *	115V 60Hz	115V 60Hz
Motor/HP	1.5 HP TEFC 1740 RPM, 180 Frame	1.5 HP TEFC 1740 RPM, 180 Frame
Spray System	N/A	N/A
Active Vacuum	N/A	N/A
Amp Draw	7.8	7.8
Vibration Compensator	1.25 Inches	1.25 Inches
Cord	2-piece 50' 12-3 SJTOW (100' 12-3 Optional)	2-piece 50' 12-3 SJTOW (100' 12-3 Optional)
Pad Pressure (lbs/in ²)***	.71	.65
Pad Pressure (lbs/ft ²)***	101.83	92.94
Total Weight **	250	305
Shipping Weight	283	341

***Unit also available in 230V, and 50 Hz**
****Weight is calculated without the power cord**
*****Pad pressure does not include the weight of the power cord.**
Specifications subject to change without notice.

<p>Features</p> <ul style="list-style-type: none"> • Twin (dual) capacitor 180 frame TEFC (Totally Enclosed Fan-Cooled) motor keeps out dirt and dust for longer motor life. • Extra heavy duty spring steel cord strain relief with a 2-piece 12-3 power cord • Low current draw • Thumb operated safety switch • Negative pressure on/off switch • Dual steel operating triggers for left or right hand operation 	<ul style="list-style-type: none"> • One-piece industrial powder coated heavy duty steel handle for optimum durability • Welded frame for rugged, reliable performance • 8" Non-marking, 2X8, ball bearing wheels • Multiple position handle adjustment for operator comfort and safety • Comfort style vinyl handle grips for ease of use • Full wraparound dust skirt
--	---

- Revolutionary Design that Utilizes.....
- Primary vibration isolators
 - Secondary vibration isolators
 - Floating head to insure 100% pad contact at all times
 - Low Profile
 - Quick handle/Carriage Removal

IMPORTANT SAFETY INSTRUCTIONS

When using an electrical appliance, basic precautions should always be followed, including the following:



WARNING:

ELECTRIC SHOCK CAN CAUSE SERIOUS INJURY OR BE FATAL. PLEASE READ THE FOLLOWING INSTRUCTIONS ON THE USE AND OPERATIONS OF FLOOR FINISHING MACHINES.

- Your TigerHawk is equipped with a safety switch lock and power switch triggers designed for your safety. Do not attempt to bypass or defeat the safety switch lock. Never use any device to lock the power switch triggers in the “ON” position.
- Do not leave the TigerHawk plugged in. Turn off the switch and unplug the electrical cord when not in use and before servicing or changing the brushes or pads.
- Do not allow the machine to be used as a toy. Close attention is necessary when used near children. Do not leave the machine connected to an electrical outlet unattended.
- Use only as described in this manual. Use only manufacturer’s recommended attachments.
- Do not use with a damaged cord or plug. If the machine is not working as it should, has been dropped, damaged, or left outdoors, return it to a service center before using.
- Use care to keep the electrical supply cord around sharp edges or corners. Keep the cord away from the heated surfaces.
- Connect to properly grounded (3-wire) outlet only. Refer to Grounding Instructions, Page 5-6.
- Do not use extension cords or outlets with inadequate current carrying capacity.
- Turn off all controls before unplugging.
- Do not unplug by pulling on the cord. To unplug, grasp the plug and pull.
- Do not handle the plug or TigerHawk with wet hands.
- Wind the cord no tighter than is necessary to retain it during storage. Refer to Cord Storage, Page 8.
- Use extra care when working on or near stairs.
- Do not use in conjunction with flammable or combustible liquids such as gasoline, or use in areas where explosive vapor or dust may be present.
- Store your TigerHawk indoors in a cool, dry area.
- Keep your work area well lighted.
- **WARNING:** To avoid electrical shock, use indoor only.



WARNING:

RISK OF EXPLOSION. FLOOR SANDING MACHINE CAN RESULT IN AN EXPLOSIVE MIXTURE OF FINE DUST AND AIR. USE FLOOR SANDING MACHINE ONLY IN A WELL-VENTILATED AREA, FREE FROM ANY FLAME OR MATCH

GROUNDING INSTRUCTIONS

This appliance must be grounded. If it should malfunction or break down, grounding provides a path of least resistance for electric current to reduce the risk of electric shock. This appliance is equipped with a cord that has an equipment-grounding conductor and grounding plug. The plug must be plugged into an appropriate outlet that is properly installed and grounded in accordance with all local codes and ordinances.

FOR FLOOR FINISHING MACHINES RATED LESS THAN 150 VOLTS

Improper connection of an equipment grounding conductor can result in risk of electric shock. Check with a qualified electrician or service person if you are in doubt as to whether the outlet is properly grounded. Do not modify the plug provided with the appliance. If it will not fit the outlet, have a proper outlet installed by a qualified electrician. This appliance is for use on a nominal 120 volt circuit and has a grounding plug that looks like the plug illustrated in Figure 1.

A temporary adapter which looks like the adapter illustrated in Figure 2 may be used to connect this plug to a two pole receptacle, as shown, if a properly grounded outlet is not available. The temporary adapter should be used only until a properly grounded outlet (Figure 1) can be installed by a qualified electrician. The green colored rigid ear, lug, or the like extending from the adapter must be connected to a permanent ground such as a properly grounded outlet box cover. Whenever the adapter is used, it must be held in place by metal screw.

FOR FLOOR FINISHING MACHINES RATED 150-220 VOLTS:

If the machine is provided with an attachment plug cap as shown in Figure 3, it is intended for use on a 240 volt (nominal) circuit. No adapter is available for this cap.



WARNING:
DO NOT USE GROUNDING
ADAPTERS ON TIGERHAWKS IN
CANADA. CHECK WITH CANADIAN CODE
FOR PROPER EQUIPMENT USAGE.
IMPROPER USE OF GROUND ADAPTORS CAN
CAUSE SERIOUS INJURY, FIRE, OR BE FATAL.

Grounding Instructions (Continued)

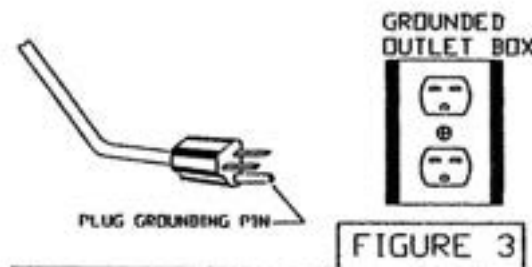
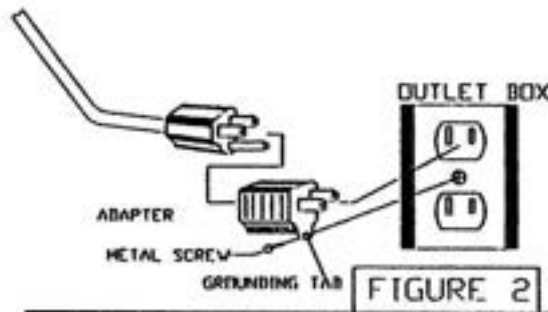
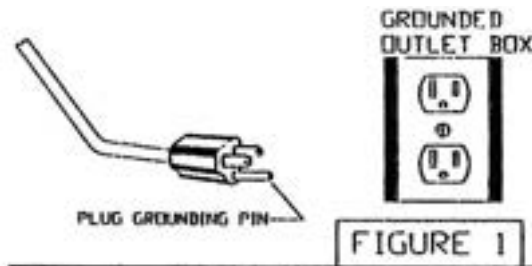

CONTROLS

TO TURN THE MACHINE ON

The operating handle must be lowered and locked to the proper operating position before switching the machine ON. Place both hands firmly on the handle grips with your fingers around the power triggers. **Do NOT** apply pressure on the triggers before the safety switch lock is disengaged.

Disengage the safety switch lock by pushing it forward with one thumb. Then, while holding the safety switch lock in the disengaged position, squeeze the power triggers toward the handle grips and return your thumb to the handle grip.

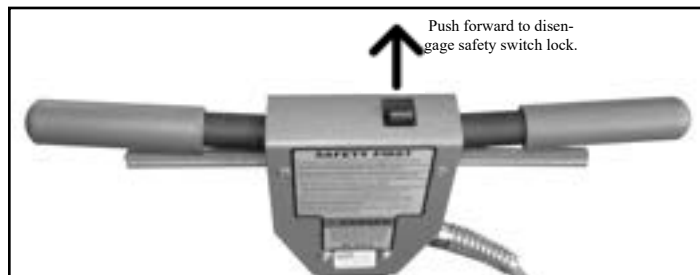

To stop the machine, simply release the triggers. The safety switch lock will automatically return to the engaged position.

GUIDELINES FOR OPERATION

- Your TigerHawk is a very sensitive, powerful unit. When in operation, it should be guided gradually and smoothly without sudden or rough motions. You will want to practice with your machine on a smooth surface until you have experience in operating it.
- For ease of operation, always keep the brush or pad surface level, balanced, and flat on the floor at all times.
- Always adjust the operating handle to a comfortable height at which the brush or pad surface is balanced before starting the machine. (See Handle Adjustment Page 4)
- Your TigerHawk will operate differently on various surfaces. For example, there will be much more resistance when the machine is used on a rough surface, than when it is used on a smooth surface. The operator should be prepared to adjust for these differences.
- **BEGIN OPERATING THE TIGERHAWK WITH THE PAD SURFACE LEVEL, BALANCED AND FLAT ON THE FLOOR.**
- To move the machine to the right, turn the unit to the right.
- To move the machine to the left, turn the unit to the left.
- To move the machine forward or backward, keep the brush or pad flat on the floor and push or pull the machine in the desired direction.

ADJUSTMENTS HANDLE ADJUSTMENT

The handle can be adjusted to any desired work position by simply pulling on the pull pin and move the handle to the desired position. Firmly push the pull pin back into the adjustment holes. This will lock the handle in position.

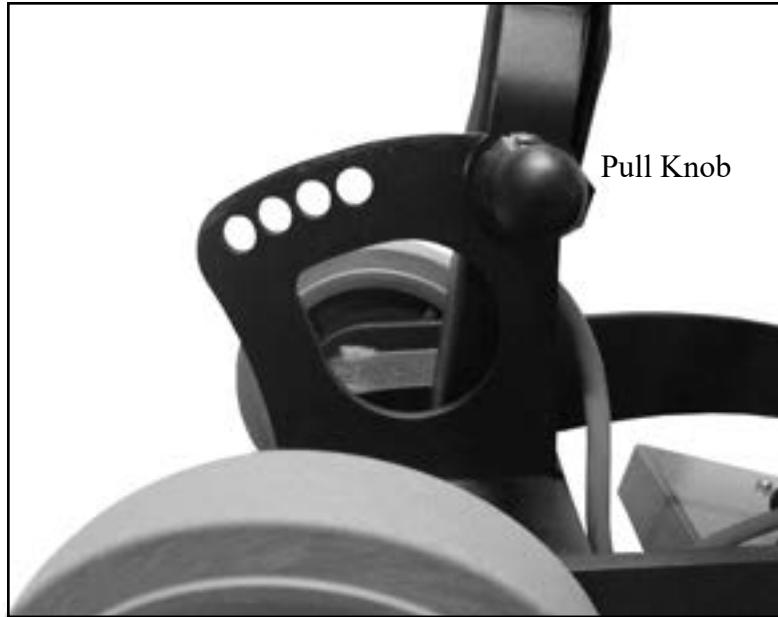

Figure 5

CORD STORAGE

When not in use, loosely coil the power cord and hang on the handle.



CLEANUP AND STORAGE

After being used, your TigerHawk can be wiped clean with a soft damp cloth and should be stored in a clean, dry place.

Tiger Hawk

2014

2814

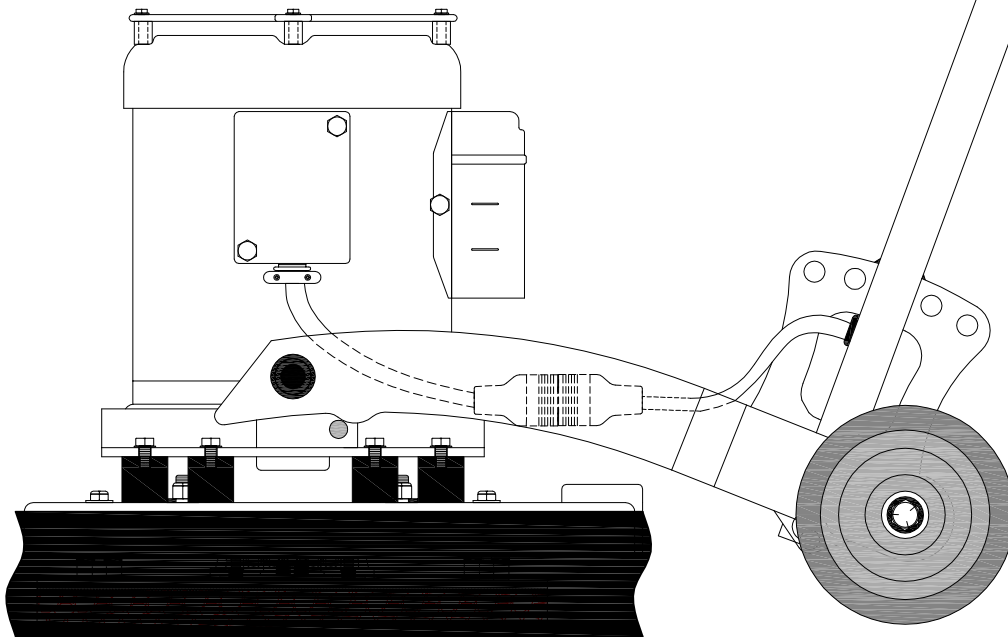

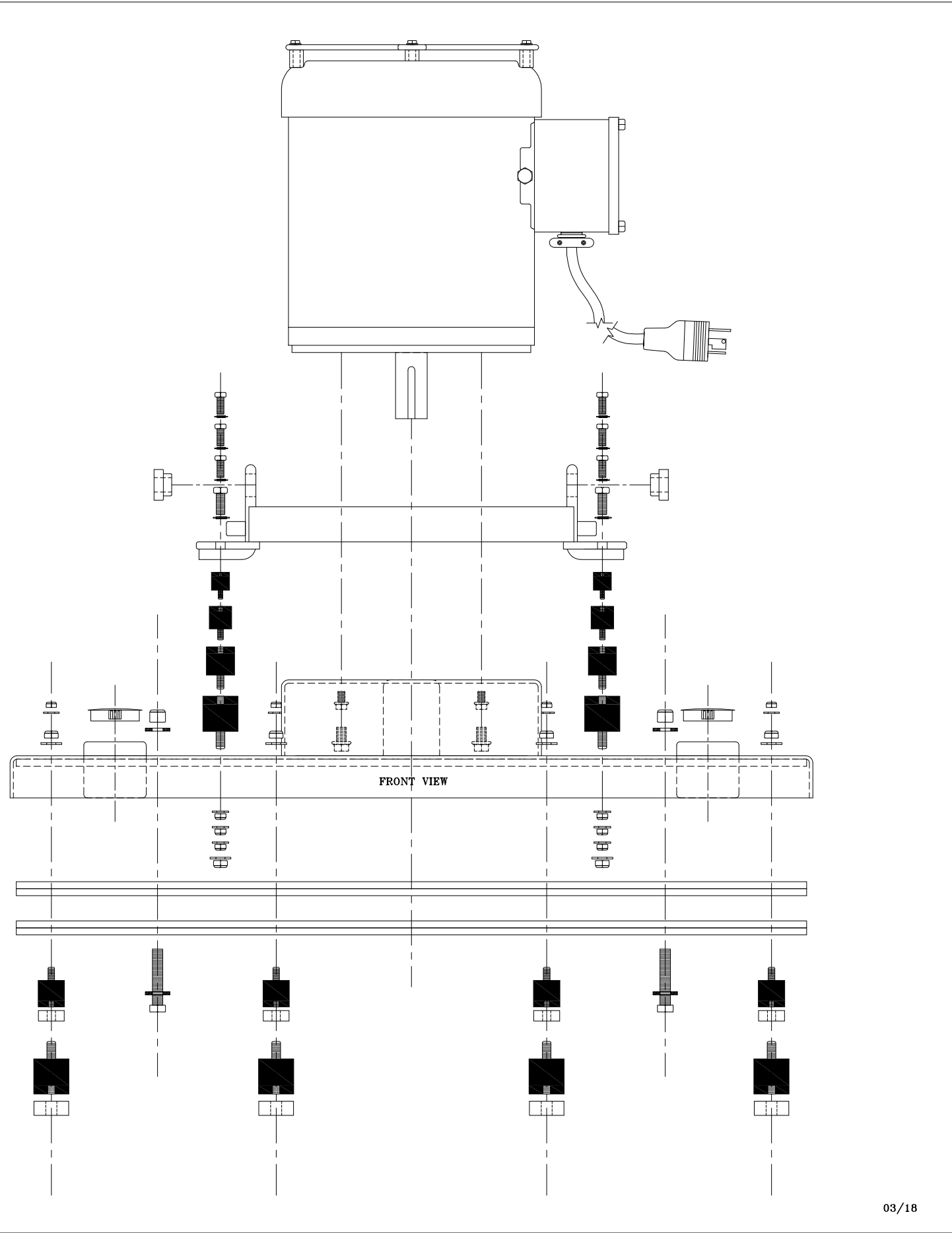

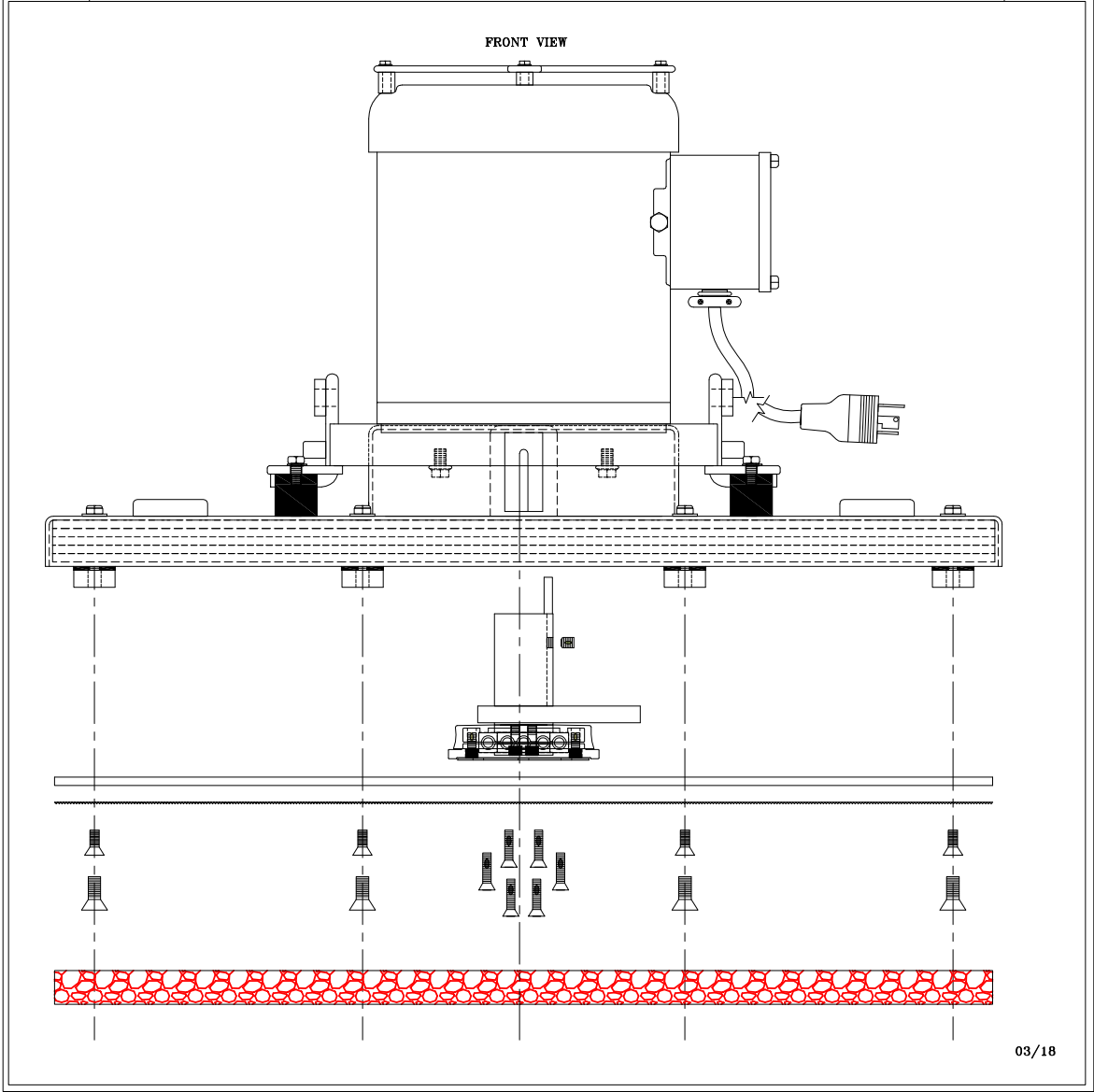
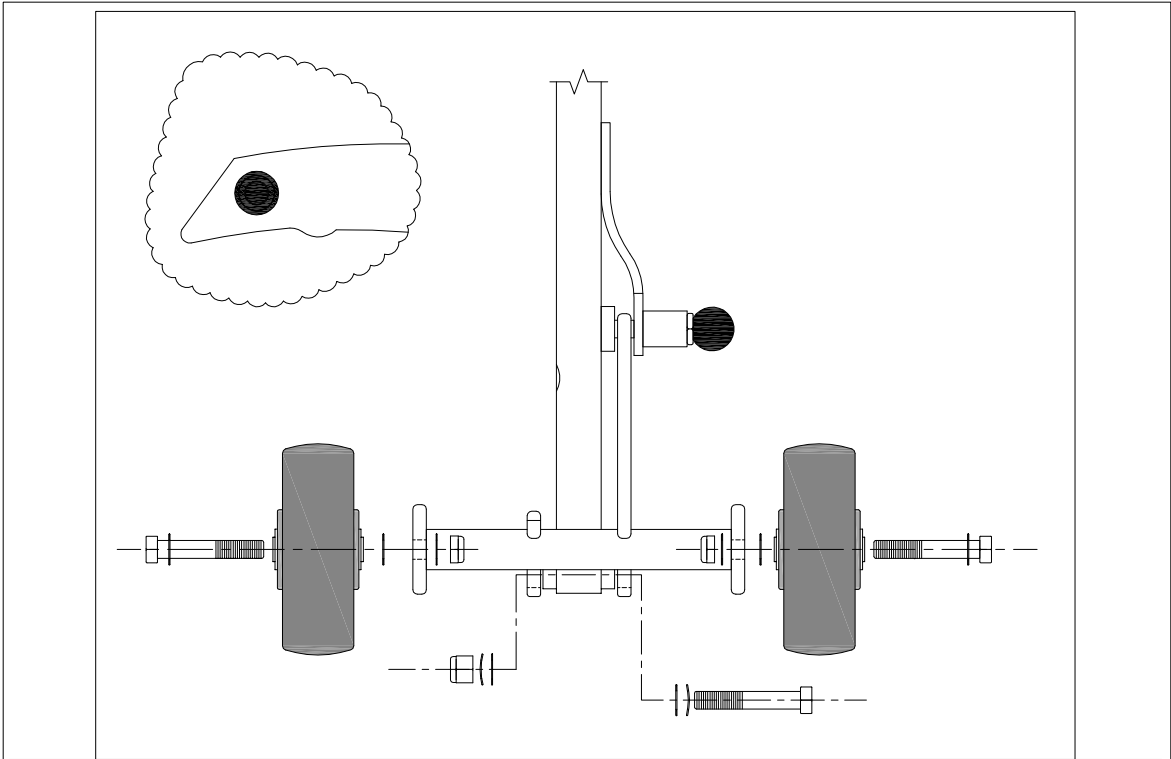

REF	DESCRIPTION	QTY
1	MOTOR 1.5HP W-GUARD ASY.	1
2	PICTAIL MOTOR 15.0"L	1
3	MOTOR KEY	1
4	MOTOR MTG. BOLTS 1/2-13 X 1.0	4

MOTOR W/MTG. HDWR.
KIT1047-1

REF	DESCRIPTION	QTY
1	NUT 5/16-18 NYLOC THIN	8
2	VIBRATION ISOLATOR 1.25 M/F	8
3	SCREW 10-24 X 1.0 FHCS	8
4	SCREW 5/16-18 X 1.0 SS FHCS	6

PRIMARY VIBRATION ISOLATOR 1.25 KIT (8)
KIT2039-1

REF	DESCRIPTION	QTY
1	SPRING KNOB ASSEMBLY	1

SPRING KNOB ASSEMBLY
KIT2028

REF	DESCRIPTION	QTY
1	TOP SHIELD BRG ECC - BLK	1
2	BEARING AXLE TOP	1
3	BEARING RETAINER TOP	1
4	BEARING #6008-2RS1/CSGIN	1
5	BEARING AXLE LOWER	1
6	SCREW SHC 1/4-20 X 1.5L	2
7	BEARING RETAINER BOTTOM	1
8	SCREW SHC 1/4-20 X 1/2 L	2
9	ECCENTRIC BOTTOM SHIELD SS	1
10	SCREW 1/4-20 X 1.25L FHSCS ZN WP	6
11	RTV GASKET MAKER	AR
12	SCREW 5/16-18 X 1.0L FHSCS (SS)	8

ECCENTRIC BEARING REPLACEMENT LESS WEIGHT
KIT3041-1

REF	DESCRIPTION	QTY
1	SECONDARY ISOLATOR BKT KIT	1
2	PIVOT BUSHING	2

SECONDARY ISOLATOR BKT.
KIT3035

REF	DESCRIPTION	QTY
1	CARRIAGE BOLT - TRU BRAND	2
2	HAIRPIN COTTER	2

CARRIAGE BOLT KIT WHEELS DOWN UNIT
KIT2028-1

REF	DESCRIPTION	QTY
1	MAIN FRAME - 2814	1

FRAME - MAIN 2814
KIT3034-1

REF	DESCRIPTION	QTY
1	BUSHING	2

BUSHING KIT - WHEELS DOWN UNITS
KIT2023

REF	PART NO.	DESCRIPTION	QTY
1	SEE TABLE	TRIGGER 14 INCH	1
2		SPRING TRIGGER	2
3		ROLL PIN 1/8 X 1.75L	2

TRIGGER REPLACEMENT KIT 14 INCH
KIT3011BLK

REF	DESCRIPTION	QTY
1	PAD DRIVER 2014	1
2	PAD DRIVER FACE VELCRO (HOOK)	1
3	SCREW 1/4-20 X 1.25L FHSCS ZN WP	4
4	SCREW 5/16-18 X 1.0L FHSCS (SS)	8
5	SPACER NYLON	8

PAD DRIVER KIT 2814
KIT3042-1

REF	DESCRIPTION	QTY
1	BOLT HEX 5/16-18 X 3/4 ZN	8
2	WASHER 5/16 EXT TOOTH LOCK	8
3	VIBRATION ISOLATOR 1.25 M/F	8
4	NUT 5/16-18 NYLOC THIN	8

SECONDARY VIBRATION ISOLATOR KIT
KIT2037-1

REF	DESCRIPTION	QTY
1	FLAT WASHER	1
2	NUT .500 CONDUIT	1
3	STRAIN RELIEF ASSY.	1

KIT2005
STRAIN RELIEF ASSY.

REF	DESCRIPTION	QTY
1	POWER CORD PICTAIL 14-3 YELLOW	1
2	SCREW 10-24 X 1.0 TT	1
3	STAR LOCK WASHER #10	3
4	NUT 1/2 CONDUIT	1
5	WASHER FLAT	1
6	STRAIN RELIEF	1

POWER CORD PIC TAIL 14-3 YELLOW
KIT1033-1

REF	DESCRIPTION	QTY
1	MAIN ON/OFF SWITCH	1
2	WASHER INTRAL TOOTH LOC 3/8	1
3	WASHER FLAT 5/16 USS	1
4	WASHER FLAT	2
5	SWITCH INSULATOR	1

MAIN SWITCH ASSY. KIT
KIT1005

NOTE: DETAIL 3 & 4 ARE USED AS REQUIRED FOR PROPER SWITCH OPERATION. SEE SWITCH INSTRUCTION BULLETIN INCLUDED WITH SWITCH KIT.

REF	DESCRIPTION	QTY
1	HANDLE GRIP - BLACK	2

HANDLE GRIP KIT - BLACK
KIT2011BLK

REF	DESCRIPTION	QTY
1	SAFETY SWITCH - 2.0 INCH	1
2	SPRING 21NG X .025 OD X .028	1

SAFETY SWITCH KIT
KIT2006

DET. NO.	DESCRIPTION	QTY.
1	CARRIAGE FRAME BLK	1
2	BUSHING	2

**CARRIAGE FRAME 2814 - BLK
KIT3025BLK**

DET. NO.	DESCRIPTION	QTY.
1	IN HANDLE CORD 55" LONG	1
2	WIRE NUT	1
3	LOOP CLAMP	1
4	SCREW 10-24 X .50	2
5	STAR WASHER #10	3
6	GROMMET HANDLE	1

**IN HANDLE CORD KIT 2814
KIT1034-1**

DET. NO.	DESCRIPTION	QTY.
1	ECCENTRIC WEIGHT ASSY.	1
2	SCREW SHC 1/4-20 X 1.50L	2
3	SCREW 5/16-18 X 1.0L FHSCS (SS)	8
4	SCREW SET 3/8-18 X 3/8L	1
5	SCREW 1/4-20 X 1.25L FHSCS	6
6	MOTOR KEY	1

**ECCENTRIC DRIVE (WEIGHT) 2814 KIT
KIT3040-3**

DET. NO.	DESCRIPTION	QTY.
1	WHEEL 6 X 2 GRAY BALL BEARING	1
2	BOLT 1/2-13 X 3.5L GR8	1
3	WASHER FLAT	5
4	WASHER SPRING (WAVE)	2
5	NUT 1/2-13 THNN NYLOC	1

**WHEEL KIT - 2814 (1)
KIT2025**

DET. NO.	DESCRIPTION	QTY.
1	ECCENTRIC ASSEMBLY COMPLETE	1
2	SET SCREW	1
3	SCREW 1/4-20 X 1.25L FHSCS ZN WP	4
4	SCREW 5/16-18 X 1.0L FHSCS (SS)	8
5	MOTOR KEY	1

**ECCENTRIC COMPLETE W HDWR 2814
KIT3037-3**

DET. NO.	DESCRIPTION	QTY.
1	BOLT 1/2-13 X 4 1/2 L GR8	1
2	WASHER SPRING (WAVE)	2
3	WASHER FLAT	2
4	NUT 1/2-13 FULL NYLOC	1

**HANDLE MGT. KIT - 2814
KIT2026**

DET. NO.	DESCRIPTION	QTY.
1	GROMMET	1
2	SCREW 10-25 X .50L	4
3	WASHER LOCK #10 EXT.	6
4	LOOP CLAMP	2
5	WIRE NUT	3
6	BUTTON PLUG .500	1

**HANDLE HDWR KIT
KIT2033-1**

DET. NO.	DESCRIPTION	QTY.
1	WEIGHT 2814	1
2	BOLT FULL THREAD 3/8-16 X 2.5L GR8	4
3	WASHER FLAT	4
4	NUT 3/8-16 NYLOC	4

**WEIGHT KIT 2814
KIT3052**

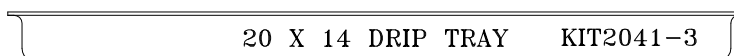
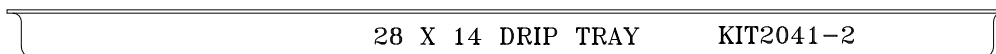
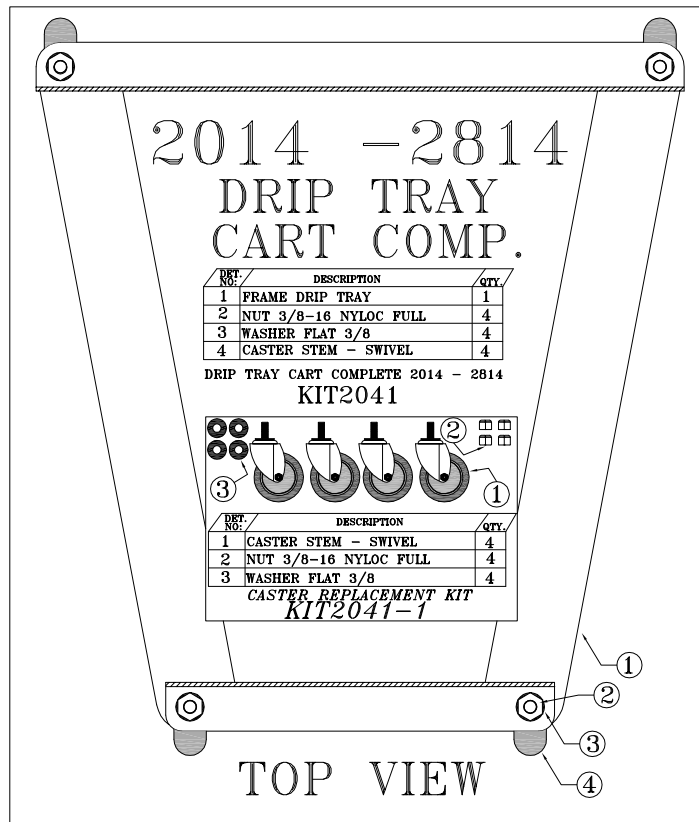
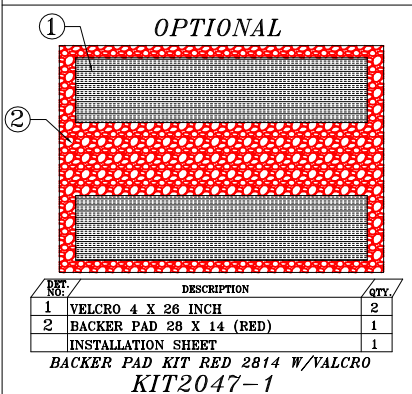
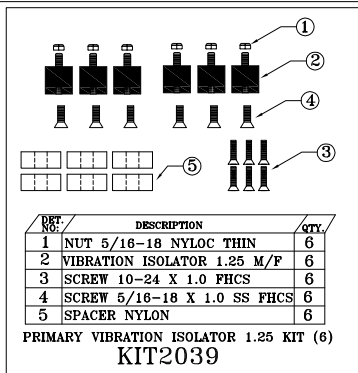
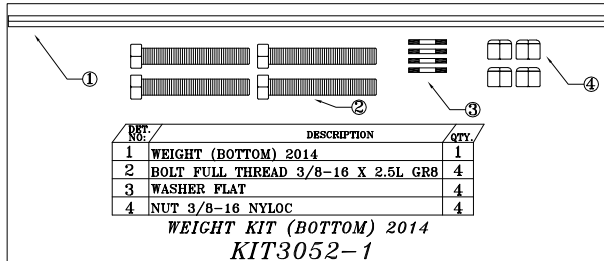
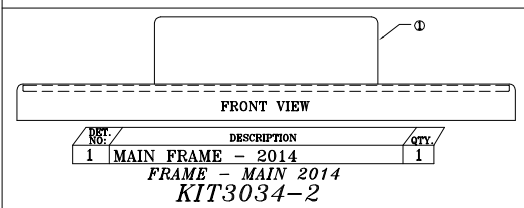
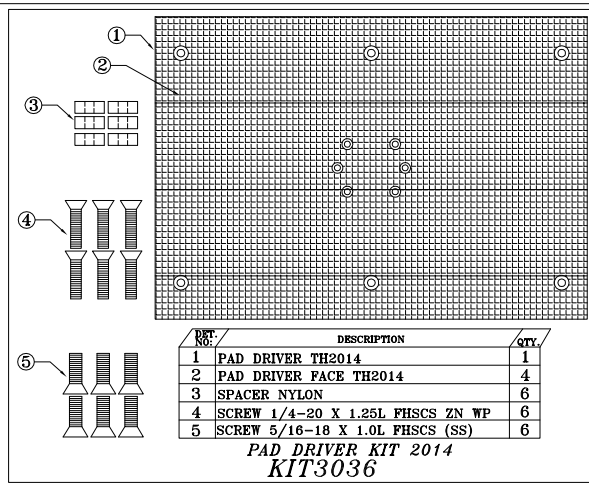
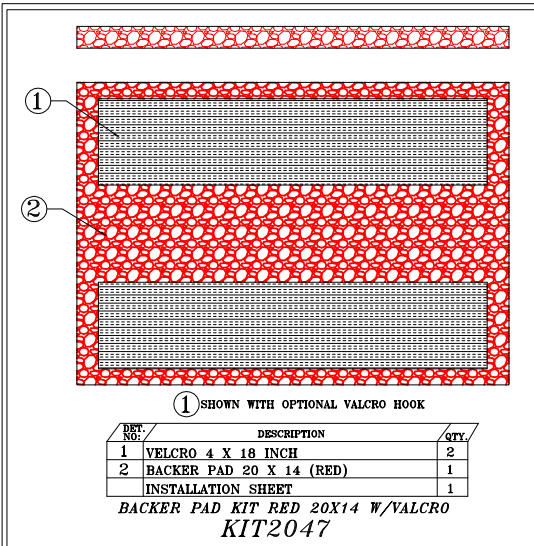

MANIFOLD MTG. HDWR

DUST CONTAINMENT MANIFOLD

REF. NO.	DESCRIPTION	QTY.
1	VACUUM HOSE DUST CONTAINMENT	1
2	VAC HOSE DUST CONTAINMENT	2
3	SCREWS MANIFOLD MTG.	4
4	SPACER NYLON	4
5	MANIFOLD VAC CONTAINMENT SYSTEM	1

VACUUM CONTAINMENT SYSTEM - 2814
KIT2054-2

REF. NO.	DESCRIPTION	QTY.
1	VACUUM HOSE DUST CONTAINMENT	1
2	BARB FITTING	1

VACUUM CONTAINMENT SYSTEM - 2014
KIT2054-4

VELCRO LOOP FOR FRAME

21.0 INCHES LONG (2 PCS.)

17.0 INCHES LONG (2 PCS.)

REF. NO.	DESCRIPTION	QTY.
1	DUST SKIRT - 2014	1
2	VELCRO LOOP 21.0L	2
3	VELCRO LOOP 17.0L	2

DUST CONTAINMENT SKIRT KIT - 2014
KIT2054-5

VELCRO LOOP FOR FRAME

29.0 INCHES LONG (2 PCS.)

17.0 INCHES LONG (2 PCS.)

REF. NO.	DESCRIPTION	QTY.
1	DUST SKIRT - 2814	1
2	VELCRO LOOP 29.0L	2
3	VELCRO LOOP 17.0L	2

DUST CONTAINMENT SKIRT KIT - 2814
KIT2054-3

REF. NO.	DESCRIPTION	QTY.
1	ECCENTRIC WEIGHT ASSY.	1
2	SCREW SHC 1/4-20 X 1.50L	2
3	SCREW 5/16-18 X 1.0L FHSCS (SS)	6
4	SCREW SET 3/8-18 X 3/8L	1
5	SCREW 1/4-20 X 1.25L FHSCS	6
6	MOTOR KEY	1

ECCENTRIC DRIVE (WEIGHT) 2014 KIT
KIT3040-3

REF. NO.	DESCRIPTION	QTY.
1	MOTOR KEY	1
2	ECCENTRIC WEIGHT ASSY.	1
3	SET SCREW	1
4	TOP SHIELD BRG ECC - BLK	1
5	BEARING AXLE TOP	1
6	BEARING RETAINER TOP	1
7	BEARING #6008-2RS1/C3GJN	1
8	BEARING AXLE LOWER	1
9	SCREW SHC 1/4-20 X 1.5L	2
10	BEARING RETAINER BOTTOM	1
11	RTV GASKET MAKER	AR
12	SCREW SHC 1/4-20 X 1/2L	2
13	ECCENTRIC BOTTOM SHIELD SS	1
14	SCREW 1/4-20 X 1.25L FHSCS	6
15	SCREW 5/16-18 X 1.0L FHSCS (SS)	6

ECCENTRIC COMP. W HDWR-2014
KIT3037-4

REF. NO.	DESCRIPTION	QTY.
1	TOP SHIELD BRG ECC - BLK	1
2	BEARING AXLE TOP	1
3	BEARING RETAINER TOP	1
4	BEARING #6008-2RS1/C3GJN	1
5	BEARING AXLE LOWER	1
6	SCREW SHC 1/4-20 X 1.5L	2
7	BEARING RETAINER BOTTOM	1
8	RTV GASKET MAKER	AR
9	SCREW SHC 1/4-20 X 1/2L	2
10	ECCENTRIC BOTTOM SHIELD SS	1
11	SCREW 1/4-20 X 1.25L FHSCS	6
12	SCREW 5/16-18 X 1.0L FHSCS (SS)	6

ECCENTRIC BEARING ASSY. W HDWR 2014
KIT3041-3

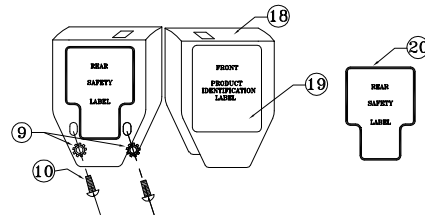
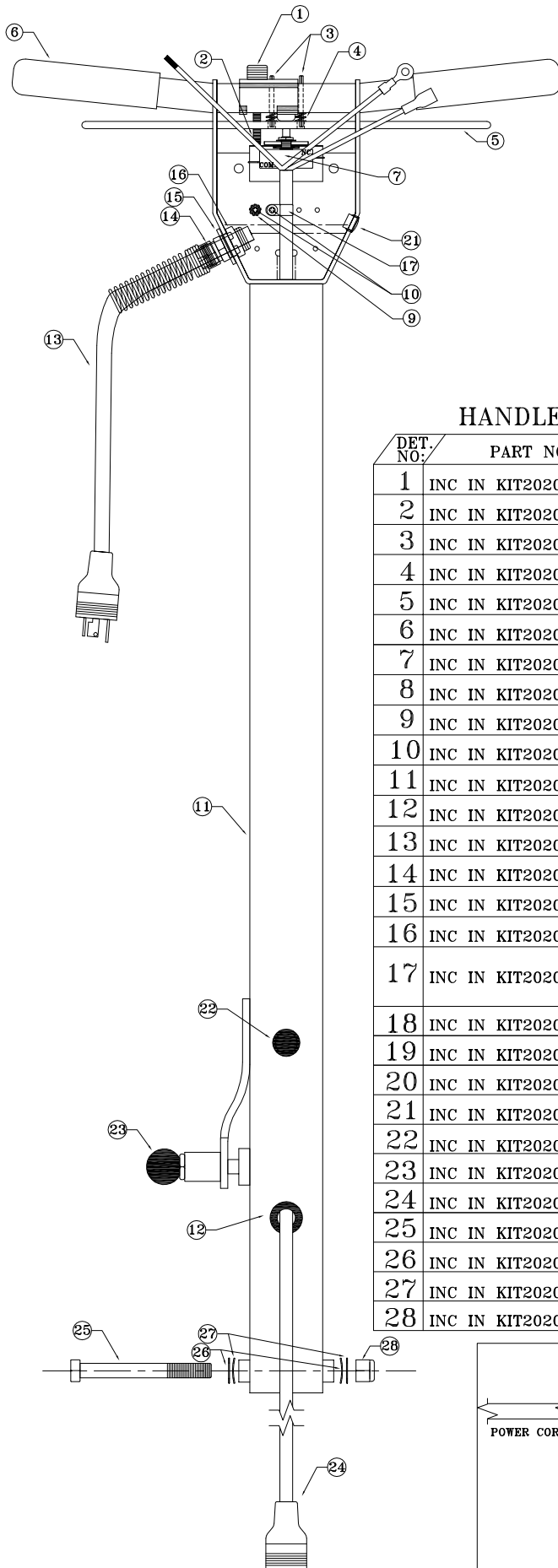

KIT2020BLKCOMP-2 HANDLE ASSEMBLY KIT COMPLETE - 2814

DET. NO.	PART NO:	DESCRIPTION	QTY.
1	INC IN KIT2020BLKCOMP-2	SAFETY SWITCH - 2.0 INCH	1
2	INC IN KIT2020BLKCOMP-2	SPRING 2.0 L	1
3	INC IN KIT2020BLKCOMP-2	ROLL PIN	2
4	INC IN KIT2020BLKCOMP-2	SPRING - TRIGGER	2
5	INC IN KIT2020BLKCOMP-2	TRIGGER GRAY	1
6	INC IN KIT2020BLKCOMP-2	HANDLE GRIP GRAY	2
7	INC IN KIT2020BLKCOMP-2	SWITCH KIT	1
8	INC IN KIT2020BLKCOMP-2	WIRE NUT	1
9	INC IN KIT2020BLKCOMP-2	STAR LOCK WASHER #10	5
10	INC IN KIT2020BLKCOMP-2	SCREW 10-24 TT	4
11	INC IN KIT2020BLKCOMP-2	HANDLE WDMT BLK	1
12	INC IN KIT2020BLKCOMP-2	GROMMET	1
13	INC IN KIT2020BLKCOMP-2	POWER CORD PIGTAIL YELLOW	1
14	INC IN KIT2020BLKCOMP-2	STRAIN RELIEF ASSEMBLY	1
15	INC IN KIT2020BLKCOMP-2	WASHER - STRAIN RELIEF	1
16	INC IN KIT2020BLKCOMP-2	NUT - STRAIN RELIEF	1
17	INC IN KIT2020BLKCOMP-2	LOOP CLAMP - IN HANDLE CORD	1
18	INC IN KIT2020BLKCOMP-2	SWITCH BOX COVER	1
19	INC IN KIT2020BLKCOMP-2	FRONT PRODUCT ID LABEL	1
20	INC IN KIT2020BLKCOMP-2	REAR SAFETY LABEL	1
21	INC IN KIT2020BLKCOMP-2	BUTTON PLUG .500 INCH	1
22	INC IN KIT2020BLKCOMP-2	BUTTON PLUG .750 INCH	1
23	INC IN KIT2020BLKCOMP-2	SPRING KNOB ASSEMBLY	1
24	INC IN KIT2020BLKCOMP-2	IN-HANDLE CORD	1
25	INC IN KIT2020BLKCOMP-2	BOLT 1/2-13 X 5 1/2L GR8	1
26	INC IN KIT2020BLKCOMP-2	WASHER FLAT	2
27	INC IN KIT2020BLKCOMP-2	WASHER WAVE	2
28	INC IN KIT2020BLKCOMP-2	NUT 1/2-13 FULL	1

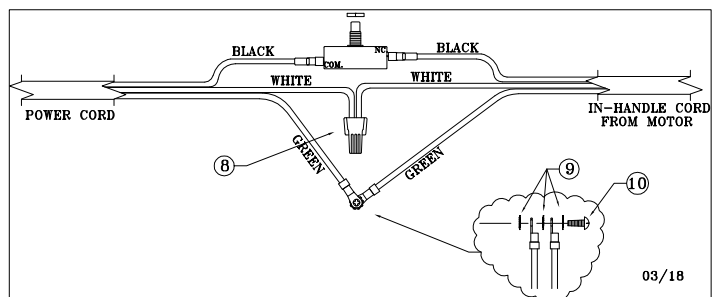

03/18

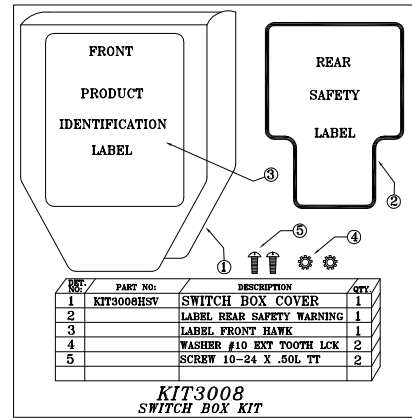
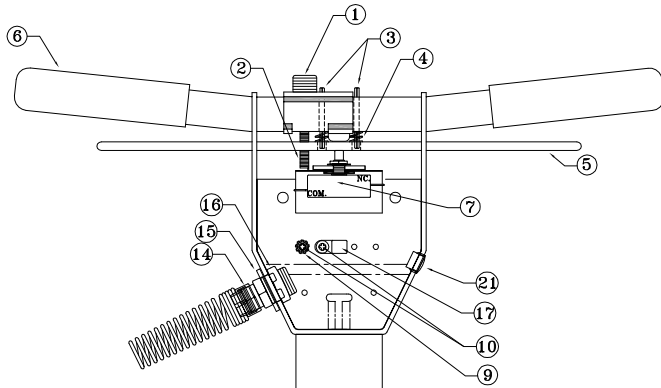

KIT2020BLK-1
HANDLE ASSEMBLY KIT PARTIAL 2814

DET. NO.	PART NO.	DESCRIPTION	QTY.
1	INC IN KIT2020BLK-1	SAFETY SWITCH - 2.0 INCH	1
2	INC IN KIT2020BLK-1	SPRING 2.0 L	1
3	INC IN KIT2020BLK-1	ROLL PIN	2
4	INC IN KIT2020BLK-1	SPRING - TRIGGER	2
5	INC IN KIT2020BLK-1	TRIGGER GRAY	1
6	INC IN KIT2020BLK-1	HANDLE GRIP GRAY	2
7	INC IN KIT2020BLK-1	SWITCH KIT	1
8	INC IN KIT2020BLK-1	WIRE NUT	1
9	INC IN KIT2020BLK-1	STAR LOCK WASHER #10	3
10	INC IN KIT2020BLK-1	SCREW 10-24 TT	2
11	INC IN KIT2020BLK-1	HANDLE WDMT BLK	1
12	INC IN KIT2020BLK-1	GROMMET	1
13	NOT INCLUDED	POWER CORD PIGTAIL YELLOW	1
14	INC IN KIT2020BLK-1	STRAIN RELIEF ASSEMBLY	1
15	INC IN KIT2020BLK-1	WASHER - STRAIN RELIEF	1
16	INC IN KIT2020BLK-1	NUT - STRAIN RELIEF	1
17	INC IN KIT2020BLK-1	LOOP CLAMP - IN HANDLE CORD	1
18	NOT INCLUDED	SWITCH BOX COVER	1
19	NOT INCLUDED	FRONT PRODUCT ID LABEL	1
20	NOT INCLUDED	REAR SAFETY LABEL	1
21	INC IN KIT2020BLK-1	BUTTON PLUG .500 INCH	1
22	INC IN KIT2020BLK-1	BUTTON PLUG .750 INCH	1
23	INC IN KIT2020BLK-1	SPRING KNOB ASSEMBLY	1
24	NOT INCLUDED	IN-HANDLE CORD	1
25	INC IN KIT2020BLK-1	BOLT 1/2-13 X 5 1/2L GR8	1
26	INC IN KIT2020BLK-1	WASHER FLAT	2
27	INC IN KIT2020BLK-1	WASHER WAVE	2
28	INC IN KIT2020BLK-1	NUT 1/2-13 FULL	1

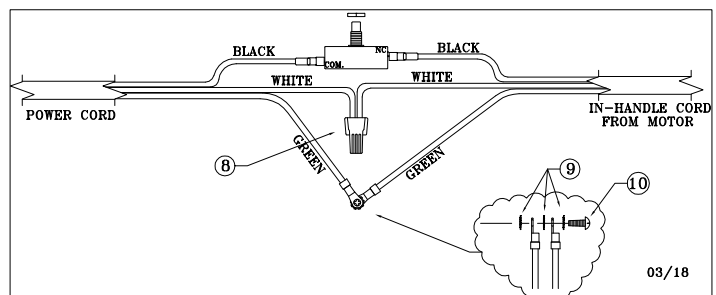
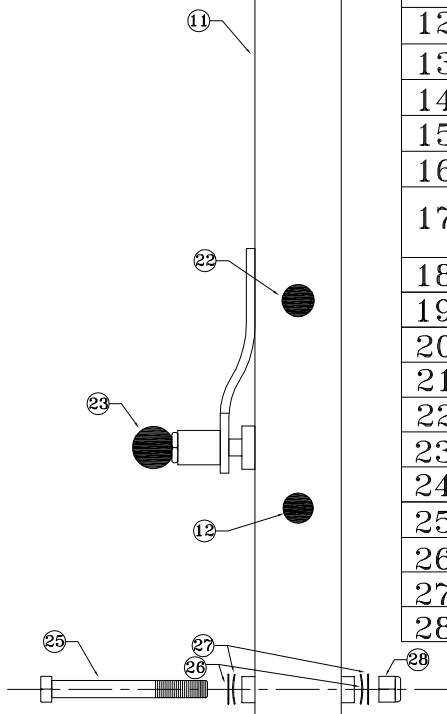



Optional integrated vacuum system (Dust skirt included with every TigerHawk)



Transport cart that comes with each unit



Optional spray system

Miscellaneous Pads



Backer Pads

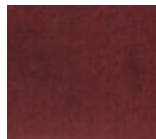

Floor Prep Pads



Pads

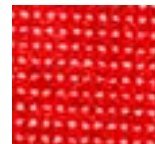

Sanding Screens

LIMITED WARRANTY

Your HAWK equipment which has been manufactured, tested and inspected in accordance with carefully specified engineering requirements, is warranted to be free from defects in material and workmanship. This Limited Warranty is, however, subject to the Following qualifications, conditions and limitations which are set forth to provide you and all users of the HAWK equipment with information concerning the duration, extent, availability, and applicability of this HAWK Limited Warranty, the procedure to be taken to obtain its performance, and other information concerning the **HAWK Limited Warranty policy**.

The HAWK ENTERPRISES Limited Warranty is extended to the original end user as follows:

Motors 1 year parts and 6 months labor

Non-wear items: 1 year parts replacement and 1 year service labor warranty.

Replacement parts guaranteed for 90 days from date of installation against defects in material and workmanship.

This Limited Warranty will not cover damage attributable to the following:

- (1) Improper, unreasonable or negligent use or abuse of the equipment
- (2) Abrasions or punctures of the equipment.

The start date of the Limited Warranty coverage shall be the purchase date of the original end user or six months from the date the machine was shipped from the Factory, whichever comes first.

PARTS OF EQUIPMENT NOT COVERED BY THE LIMITED WARRANTY

Certain parts of equipment require replacement in the ordinary use due to normal wear by reason of their characteristics. Normal wear items such as cords, switches, bumpers, bearings, isolators, compensators, capacitors etc. are excluded from the Limited Warranty.

EXCEPTIONS AND EXCLUSIONS FROM THE LIMITED WARRANTY

This equipment is required to be used on electric current as indicated on the data plate. Otherwise damage, defects, malfunctions or other failure of the equipment arising from use on electric current not as indicated are excepted and excluded from this Limited Warranty. Defects, malfunctions, failure or damage of the equipment caused by improper, unreasonable or neglect use or abuse while in possession of the purchaser are likewise excluded from this warranty. If repair is done on your equipment by anyone other than those designated as authorized to perform such work without first having obtained factory instructions, HAWK ENTERPRISES at its sole option, may determine that this warranty will not apply and that reimbursement for such repair will not be made because of the failure to comply with such factory specified instructions.

PROCEDURE TO BE TAKEN TO OBTAIN PERFORMANCE OF LIMITED WARRANTY REPAIR

To secure repair of the equipment or any warranted parts under this Limited Warranty, the following procedure should be taken. The inoperative equipment or warranted parts, together with satisfactory evidence of the purchase date, must be delivered, with shipping and delivery charges prepaid, to one of the following:

- (1) The dealer from whom purchased;
- (2) Any HAWK distributor's service department in the United States;
- (3) Any HAWK authorized service station in the United States.

If you are unable to locate any of the foregoing, you may write or otherwise communicate with HAWK ENTERPRISES before repair service is performed by anyone else. In such event, HAWK ENTERPRISES will provide either the location or a closely available HAWK distributor service department, or HAWK authorized service station or other factory instructions. Upon compliance with the above procedure, all warranted defects will be repaired, at no additional charge or costs to the customer, and the repaired product returned to the customer, with all shipping and delivery charges pre-paid. In following the procedures set forth, PLEASE MAKE CERTAIN to state the model, type and serial number as shown on the data plate of the equipment.

REPLACEMENT

In the event of a defect, malfunction or failure of your HAWK equipment or any warranted part to conform with this warranty, HAWK may, at its sole option and own expense, replace the equipment or any warranted part with another new, identical or reasonably equivalent model or part in lieu or repairing the defect. **DO NOT** return any equipment or part to the factory without prior authorization.

NO REFUND OF PURCHASE PRICE

HAWK ENTERPRISES **WILL NOT**, as a matter of its Limited Warranty policy, refund the customer's purchase price.

LIMITED WARRANTY REGISTRATION CARD FOR YOUR EQUIPMENT AND REQUEST FOR INFORMATION

Your HAWK distributor from whom you purchased your equipment is responsible for the registration of your Limited Warranty with the factory. Any information or questions you may have concerning your HAWK ENTERPRISES equipment or this Limited Warranty may likewise be secured from the factory. This Limited Warranty will give you specific legal rights, and you may also have other rights which vary from state to state.