

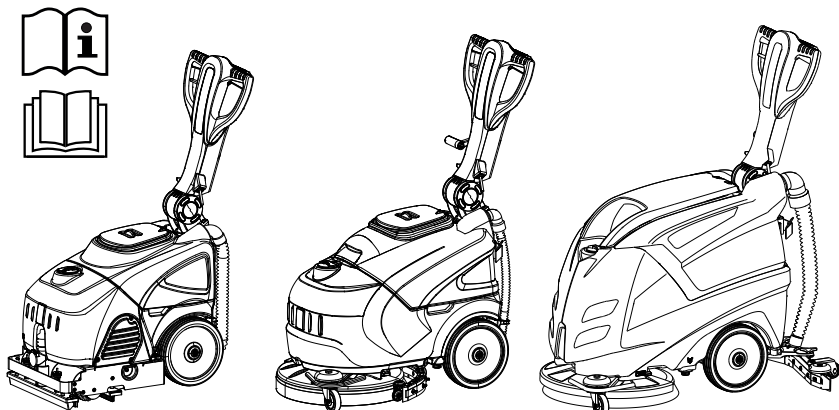

CT15R - CT30 - CT45 - CT46 - CT15 ECS - Lavamatic 360 - Lavamatic 46 - Lavamatic 15R - Lavamatic 30 - Lavamatic 45



(IT) MANUALE ISTRUZIONI PER L'USO / **(EN)** OPERATOR'S MANUAL /
(FR) MANUEL D'INSTRUCTIONS / **(DE)** BEDIENUNGSANLEITUNG /
(ES) MANUAL DE INSTRUCCIONES / **(NO)** BRUKERHÅNDBOK /
(NL) GEBRUIKERSHANDLEIDING / **(PT)** MANUAL DE UTILIZAÇÃO /
(SE) INSTRUKTIONSBOK / **(RU)** РУКОВОДСТВО ОПЕРАТОРА /
(BG) РЪКОВОДСТВО ЗА ЕКСПЛОАТАЦИЯ / **(CN)** 操作手册 /
(RO) MANUAL DE UTILIZARE

Consultare attentamente questo manuale prima di procedere a qualsiasi intervento sulla macchina
Read this manual carefully before carrying out any work on the machine
Lire attentivement ce manuel avant toute intervention sur la machine
Vorliegendes Handbuch vor jedem Eingriff an der Maschine aufmerksam durchlesen
Consulte detenidamente este manual antes de llevar a cabo cualquier trabajo en la máquina
Konsulter denne håndboken nøye før du går i gang med noen som helst type inngrep på maskinen
Raadpleeg deze handleiding aandachtig alvorens met enige werkzaamheid aan de machine te beginnen
Consulte atentamente este manual antes de efectuar cualquier intervención en a máquina
Läs noggrant igenom denna handbok innan du utför något som helst ingrepp på maskinen
Прочетете внимателно това ръководство, преди да започнете работа с машината
Внимательно ознакомьтесь с данной инструкцией до проведения любой работы с машиной
操作机器之前请认真阅读本手册
Citiți cu atenție acest manual înainte de a efectua orice operațiuni asupra mașinii

ENGLISH
**(Translation of original
instructions)**



CT15 TECHNICAL SPECIFICATIONS	5
CT30 TECHNICAL SPECIFICATIONS	7
CT45 TECHNICAL SPECIFICATIONS	9
CT46 TECHNICAL SPECIFICATIONS	11
MACHINE DIMENSIONS	13
SAFETY SYMBOLS	15
Battery charger	16
Figure	17
GENERAL INFORMATION	24
Scope of the manual	24
Identifying the machine	24
Documentation provided with the machine	24
TECHNICAL INFORMATION	25
General description	25
Legend	25
Danger zones	25
Accessories	25
SAFETY INFORMATION	25
Safety regulations	25
HANDLING AND INSTALLATION	27
Lifting and transporting the packaged machine	27
Checks on delivery	28
Unpacking	28
Electrical connections and earth (cable models)	28
Power supply batteries (battery models)	28
Batteries: preparation	28
Batteries: installation and connection	29
Batteries: removal	29
Battery charger (battery models)	29
Scelta del caricabatteria	30
Preparing the battery charger	30
Lifting and transporting the machine	30
PRACTICAL GUIDE FOR THE OPERATOR	30
Controls - Description	30
Mounting and adjusting the squeegee	31
To move the machine, proceed as follows:	32
Mounting and changing the brush/drive disks	32
Detergents - Instructions	32
Preparing the machine for work	33
Working	33
At the end of work:	34
Some useful tips to get the most from your scrubber drier	34
Carpet accessory	34
Combi accessory	35
Draining the dirty water	35
Draining the clean water	35
PERIODS OF INACTIVITY	35
BATTERY MAINTENANCE AND CHARGING	36
MAINTENANCE INSTRUCTIONS	36
Maintenance - General rules	36
Routine maintenance	36
Squeegee blades: replacing	37
Fuses: replacement (battery models) (Fig. L)	37
Fuses: replacement (cable models) (fig. M)	37
Routine maintenance	37
Six monthly operations	38
TROUBLESHOOTING	38

How to resolve possible problems	38
Error codes displayed, battery version.....	40

CT15 TECHNICAL SPECIFICATIONS

		CT15 C35R 230V	CT15 C35R 115V	CT15 B35R	CT15B B35 ECS
Cleaning width	mm	360	360	360	355
Squeegee width	mm	430	430	430	450
Cleaning capacity per hour	m ² /h	1260	1260	1260	1150
Number of brushes	no.	1			
Brush diameter	mm	100	100	100	330
Maximum brush pressure	g/cm ²	/	/	/	/
Brush rotation speed	rpm	965	820	890	600
Brush motor power	W	370	370	300	450
Drive motor power	W	/			
Suction motor power	W	461	430	294	294
Machine power in average operating conditions (P _M)	W	1012	956	600	648
Maximum speed	km/h	/			
Solution tank	l	15			
Dirty water tank	l	16,5			
Rear wheel diameter	mm	250			
Negotiable gradient	%	2			
Gross weight (GVW)	kg	68	68	77	74
Weight of the machine in transit without batteries	kg	52	52	39	36
Weight of the machine in transit with batteries	kg	/	/	61	58
Number of batteries	no.	/	/	2	2
Machine voltage V _M	V	/	/	12x2	12x2
Individual battery capacity	Ah (5h)	/	/	29	29
Mains supply voltage, V	V / Hz	220-240Vac 50-60Hz	115Vac 60Hz	100-240Vac 50-60Hz	100-240Vac 50-60Hz
Max current (amperes), I	A	6	10	1,3	1,3
Machine dimensions	mm	X=750 Y=435 Z=1170 Z=806	X=750 Y=435 Z=1170 Z=806	X=750 Y=435 Z=1170 Z=806	X=782 Y=4685 Z=1170 Z=806
Battery compartment dimensions (length, width, height)	mm	/	/	205 x 265 x 205	205 x 265 x 205
Packed size (length, width, height)	mm	900x610x975	900x610x975	900x610x975	800 x 450 x 640

Sound pressure - Annex DD (Emission of acoustical noise) EN 60335-2-72: 2012	LpA (dBA)	74	74	72	66
Measurement uncertainty	K (dBA)	3	3	3	3
Vibration level (hand) - IEC 60335-2-72	ahv m/sec ²	≤2.5	≤2.5	≤2.5	≤2.5
Measurement uncertainty, k	m/sec ²	/	/	/	/
Vibration level (body) - IEC 60335-2-72	HBV m/sec ²	/	/	/	/
Measurement uncertainty, k	m/sec ²	/	/	/	/
Maximum water and detergent temperature	°C	55			
IP degree	IP	IPX3			

Gross weight (GVW): maximum permissible weight with the machine fully loaded and ready for use. The gross weight of the machine includes the detergent solution tank full of clean water, empty dirty water tank (half full in the case of recycling systems), empty dust bags, the hopper filled to its rated capacity, the largest recommended batteries and all accessories such as cables, hoses, detergent, mops and brushes.

Transported weight: the weight of the machine including batteries, but excluding optionals (for example, the operator's cabin, FOPS (Falling Object Protective Structure), second and third side brushes and front brush attachment), fresh water (in the case of scrubbers or combination machines) and the weight of a standard operator (75 kg).

Data subject to changes without prior warning

V, I: charging / supply values

V_M, P_M: machine in operation (all functions on)

CT30 TECHNICAL SPECIFICATIONS

		CT30 B45	CT30 C45 230V	CT30 C45 115V
Cleaning width	mm	455		
Squeegee width	mm	545		
Cleaning capacity per hour	m ² /h	1600		
Number of brushes	no.	1		
Brush diameter	mm	455		
Maximum brush pressure	g/cm ²	/		
Brush rotation speed	rpm	150	140	140
Brush motor power	W	400	450	450
Drive motor power	W	/		
Machine power in average operating conditions (P _M)	W	528	828	828
Maximum speed	km/h	/		
Solution tank	l	28		
Dirty water tank	l	30		
Rear wheel diameter	mm	250		
Negotiable gradient	%	2		
Gross weight (GVW)	kg	126	81	81
Weight of the machine in transit without batteries	kg	48	51	51
Weight of the machine in transit with batteries	kg	96	/	/
Number of batteries	no.	2	/	/
Machine voltage V _M	V	12x2	/	/
Individual battery capacity	Ah (5h)	74	/	/
Mains supply voltage, V	V / Hz	100-240Vac 50-60Hz	220-240Vac 50-60Hz	115Vac 60Hz
Max current (amperes), I	A	4	4,8	9
Machine dimensions	mm	X=850 Y=575 Z=1220 Z=745		
Battery compartment dimensions (length, width, height)	mm	240x330x220	/	/
Packed size (length, width, height)	mm	900x610x960		

Sound pressure - Annex DD (Emission of acoustical noise) EN 60335-2-72: 2012	LpA (dBA)	73	72	72
Measurement uncertainty	K (dBA)	3	3	3
Vibration level (hand) - IEC 60335-2-72	ahv m/sec ²	≤2.5	≤2.5	≤2.5
Measurement uncertainty, k	m/sec ²	/	/	/
Vibration level (body) - IEC 60335-2-72	HBV m/sec ²	/	/	/
Measurement uncertainty, k	m/sec ²	/	/	/
Maximum water and detergent temperature	°C	55		
IP degree	IP	IPX3	IPX3	IPX3

Gross weight (GVW): maximum permissible weight with the machine fully loaded and ready for use. The gross weight of the machine includes the detergent solution tank full of clean water, empty dirty water tank (half full in the case of recycling systems), empty dust bags, the hopper filled to its rated capacity, the largest recommended batteries and all accessories such as cables, hoses, detergent, mops and brushes.

Transported weight: the weight of the machine including batteries, but excluding optionals (for example, the operator's cabin, FOPS (Falling Object Protective Structure), second and third side brushes and front brush attachment), fresh water (in the case of scrubbers or combination machines) and the weight of a standard operator (75 kg).

Data subject to changes without prior warning

V, I: charging / supply values

V_M, P_M: machine in operation (all functions on)

CT45 TECHNICAL SPECIFICATIONS

		CT45 B50	CT45 BT50	CT45 C50 230V	CT45 C50 115V
Cleaning width	mm	500			
Squeegee width	mm	730			
Cleaning capacity per hour	m ² /h	1750			
Number of brushes	no.	1			
Brush diameter	mm	500			
Maximum brush pressure	g/cm ²	/			
Brush rotation speed	rpm	155	155	140	140
Brush motor power	W	360	360	450	450
Drive motor power	W	/	180	/	/
Suction motor power	W	294	294	461	461
Machine power in average operating conditions (P _M)	W	432	672	828	828
Maximum speed	km/h	/	3,5	/	/
Solution tank	l	40			
Dirty water tank	l	45			
Rear wheel diameter	mm	250			
Negotiable gradient	%	2			
Gross weight (GVW)	kg	146	151	105	105
Weight of the machine in transit without batteries	kg	55	60	65	65
Weight of the machine in transit with batteries	kg	103	108	/	/
Number of batteries	no.	2	2	/	/
Machine voltage V _M	V	12x2	12x2	/	/
Individual battery capacity	Ah (5h)	74	74	/	/
Mains supply voltage, V	V / Hz	100-240Vac 50-60Hz	100-240Vac 50-60Hz	220-240Vac 50-60Hz	115Vac 60Hz
Max current (amperes), I	A	4	4	4,8	9
Machine dimensions	mm	X=986 Y=710 Z=1283 Z=806			
Battery compartment dimensions (length, width, height)	mm	265x335x255	265x335x255	/	/
Packed size (length, width, height)	mm	1020x720x975			

Sound pressure - Annex DD (Emission of acoustical noise) EN 60335-2-72: 2012	LpA (dBA)	72	72	73	73
Measurement uncertainty	K (dBA)	3	3	3	3
Vibration level (hand) - IEC 60335-2-72	ahv m/sec ²	≤2.5	≤2.5	≤2.5	≤2.5
Measurement uncertainty, k	m/sec ²	/	/	/	/
Vibration level (body) - IEC 60335-2-72	HBV m/sec ²	/	/	/	/
Measurement uncertainty, k	m/sec ²	/	/	/	/
Maximum water and detergent temperature	°C	55			
IP degree	IP	IPX3			

Gross weight (GVW): maximum permissible weight with the machine fully loaded and ready for use. The gross weight of the machine includes the detergent solution tank full of clean water, empty dirty water tank (half full in the case of recycling systems), empty dust bags, the hopper filled to its rated capacity, the largest recommended batteries and all accessories such as cables, hoses, detergent, mops and brushes.

Transported weight: the weight of the machine including batteries, but excluding optionals (for example, the operator's cabin, FOPS (Falling Object Protective Structure), second and third side brushes and front brush attachment), fresh water (in the case of scrubbers or combination machines) and the weight of a standard operator (75 kg).

Data subject to changes without prior warning

V, I: charging / supply values

V_M, P_M: machine in operation (all functions on)

CT46 TECHNICAL SPECIFICATIONS

			CT46 B50	CT46 C50
Cleaning width		mm	500	
Squeegee width		mm	730	
Cleaning capacity per hour		m ² /h	1750	
Number of brushes		no.	1	
Brush diameter		mm	500	
Maximum brush pressure		g/cm ²	16-20	
Brush rotation speed		rpm	155	140
Brush motor power		W	360	450
Drive motor power		W	/	
Suction motor power		W	294	461
Machine power in average operating conditions (P _M)		W	432	828
Maximum speed		km/h	/	
Solution tank		l	40	
Dirty water tank		l	45	
Rear wheel diameter		mm	250	
Negotiable gradient		%	2	
Gross weight (GVW)		kg	190	104
Weight of the machine in transit without batteries		kg	60	64
Weight of the machine in transit with batteries		kg	148	/
Number of batteries		no.	2	/
Machine voltage V _M		V	12x2	/
Individual battery capacity		Ah (5h)	105	/
Supply voltage (battery recharge)	Version without on board battery charger	V	24Vdc	
Max current (battery recharge)		A	15	
Mains supply voltage	Mains powered versions with on board charger	V	100-240Vac 50-60Hz	220-240Vac 50-60Hz
Max current (amperes), I		A	4,8	9
Machine dimensions		mm	X=1065 Z=1280 Z=950 Y=715	

Battery compartment dimensions (length, width, height)		mm	340x355x305	/
Packed size (length, width, height)		mm	1070x680x1130	
Sound pressure - Annex DD (Emission of acoustical noise) EN 60335-2-72: 2012		LpA (dBA)	70	73
Measurement uncertainty		K (dBA)	3	3
Vibration level (hand) - IEC 60335-2-72		ahv m/sec ²	≤2.5	≤2.5
Measurement uncertainty, k		m/sec ²	/	/
Vibration level (body) - IEC 60335-2-72		HBV m/sec ²	/	/
Measurement uncertainty, k		m/sec ²	/	/
Maximum water and detergent temperature		°C	55	
IP degree		IP	IPX3	

The suffix +CB following the description of the model on the machine identification data plate indicates that there is a battery charger installed on the machine in question.

Gross weight (GVW): maximum permissible weight with the machine fully loaded and ready for use. The gross weight of the machine includes the detergent solution tank full of clean water, empty dirty water tank (half full in the case of recycling systems), empty dust bags, the hopper filled to its rated capacity, the largest recommended batteries and all accessories such as cables, hoses, detergent, mops and brushes.

Transported weight: the weight of the machine including batteries, but excluding optionals (for example, the operator's cabin, FOPS (Falling Object Protective Structure), second and third side brushes and front brush attachment), fresh water (in the case of scrubbers or combination machines) and the weight of a standard operator (75 kg).

Data subject to changes without prior warning

V, I: charging / supply values

V_M, P_M: machine in operation (all functions on)

MACHINE DIMENSIONS

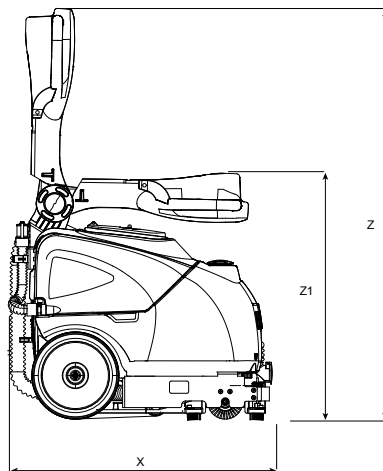
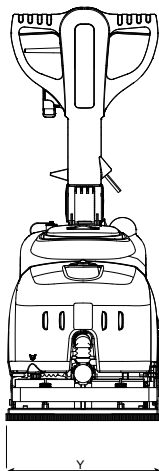
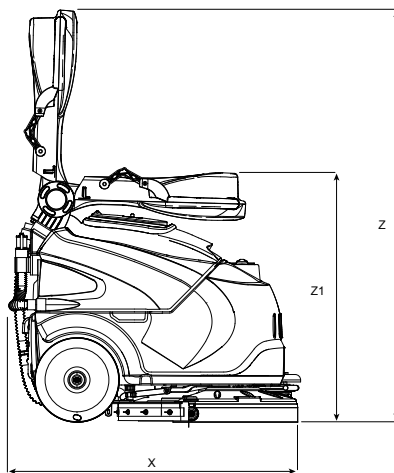
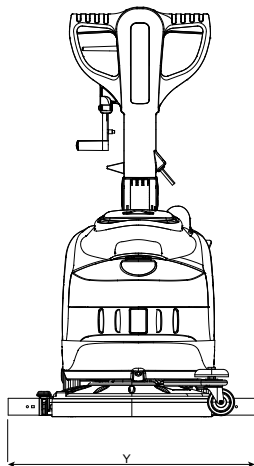



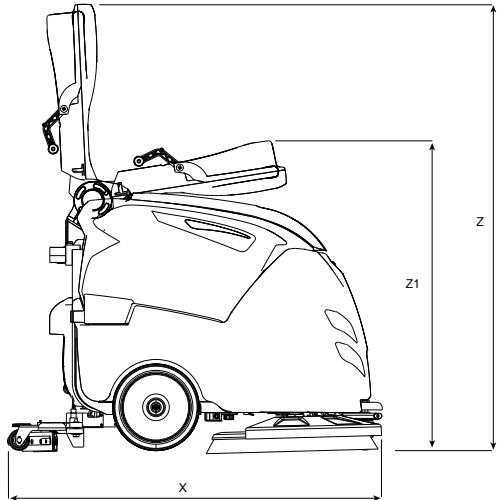
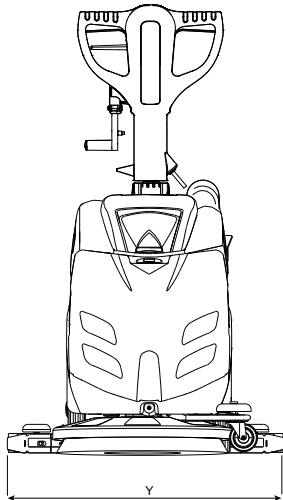
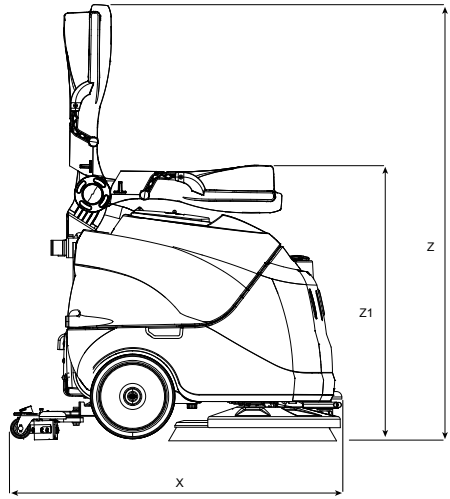
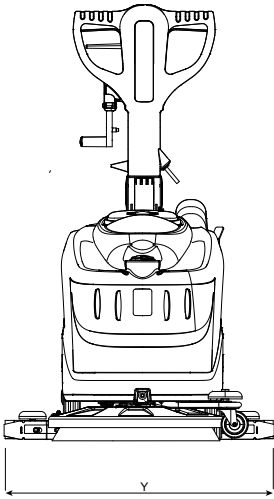







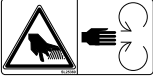

X-Y-Z: See "TECHNICAL SPECIFICATIONS" table



X-Y-Z: See "TECHNICAL SPECIFICATIONS" table

SAFETY SYMBOLS

	WARNING! RISK OF CUTTING
	WARNING! RISK OF CRUSHING LIMBS
	WARNING! RISK OF ABRASION
	WARNING! RISK OF ENTANGLEMENT
	WARNING! RISK OF ACID BURNS
	WARNING! RISK OF BURNS
	MAXIMUM SLOPE
	OPERATOR'S MANUAL, OPERATING INSTRUCTIONS
	READ THE OPERATOR'S MANUAL
	DIRECT CURRENT SYMBOL
	INSULATION CLASS, THIS CLASSIFICATION ONLY APPLIES TO MACHINES POWERED BY BATTERIES.
	EXTERNAL BATTERY CHARGER CONNECTION POINT

BATTERY CHARGER

Dipswitches are located behind the round black cap located on the front side of the charger and next to the green led you will find 2 sets of dipswitches (SW1 and SW2).

CT15			
SW1		SW2	
DP1	DP2	DP1	DP2
Charging current	Charging Termination	Curve	TCL Function
ON: half charging current (2,5A)	ON: stop charge	OFF: IUUO-GEL for generic GEL and AGM batteries	OFF: TCL enabled
OFF: maximum charging current (5A) Default Setting	OFF: floating charge at 27,6V Default Setting	ON: IUla-AGM DISCOVER for DISCOVER AGM batteries Default Setting	ON: TCL disabled Default Setting

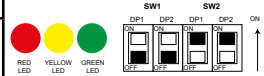

CT30 ECO			
SW1		SW2	
DP1	DP2	DP1	DP2
Charging current	Charging Termination	Curve	TCL Function
ON: half charging current (2,5A)	ON: stop charge	ON: IUla-AGM DISCOVER for DISCOVER AGM batteries	OFF: TCL enabled
OFF: maximum charging current (5A) Default Setting	OFF: floating charge at 27,6V Default Setting	OFF: IUUO-GEL for generic GEL and AGM batteries Default Setting	ON: TCL disabled Default Setting

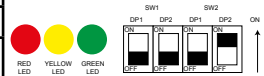

CT30 - CT45						
SW1			SW2			
DP1	DP2	Curve	DP1	V	DP2	
ON	OFF	IUla-ACD for Wet batteries	OFF	24	ON	TCL disabled Default Setting
OFF	OFF	IUla-GEL for GEL batteries of Exide-Sonnenschein and Haze	ON	12	OFF	TCL enabled
OFF	ON	IUUO-GEL for GEL and AGM batteries of other manufacturers				
ON	ON	IUla-AGM for Discover AGM batteries Default Setting				

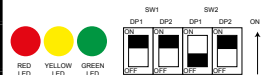

FIGURE

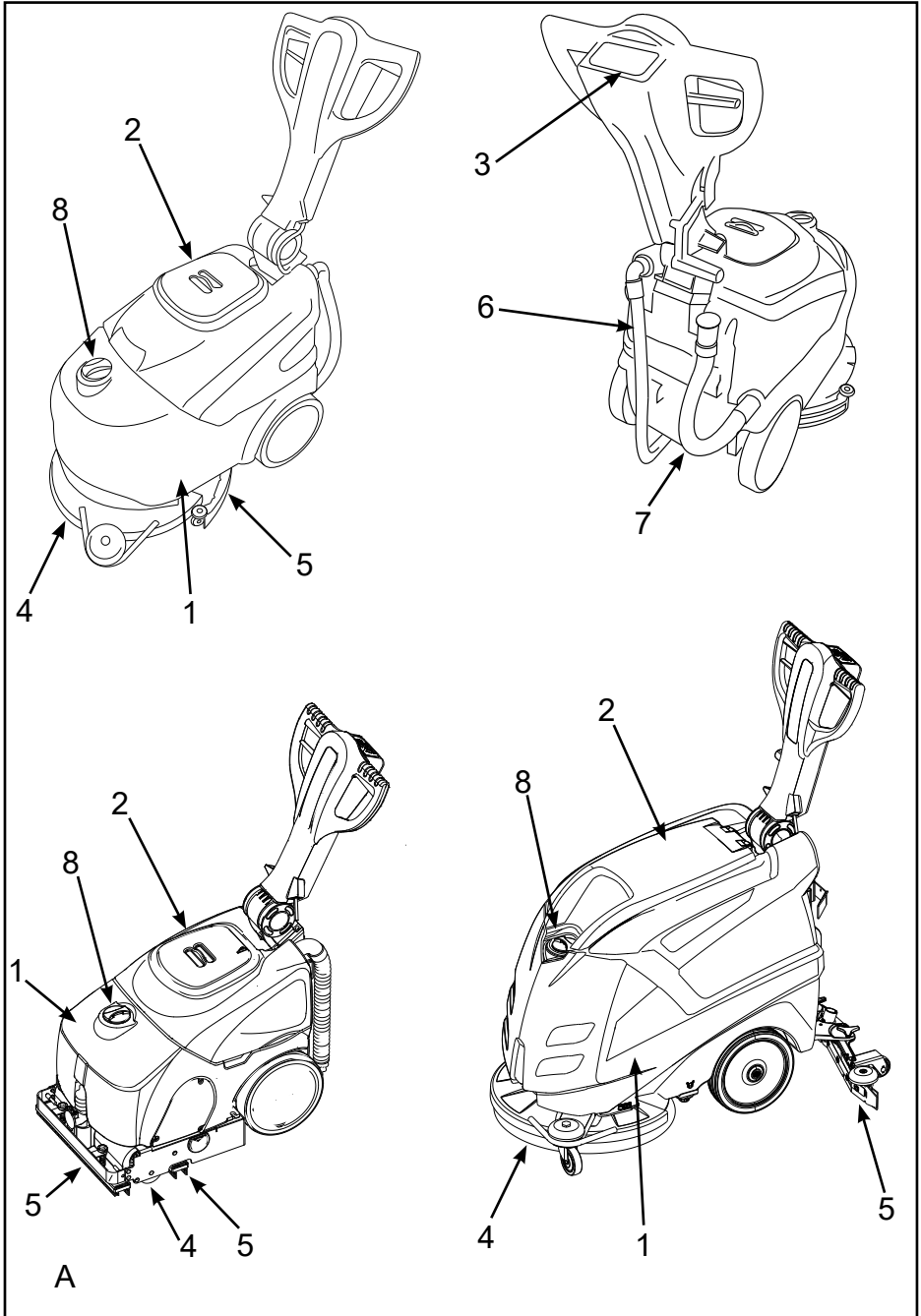

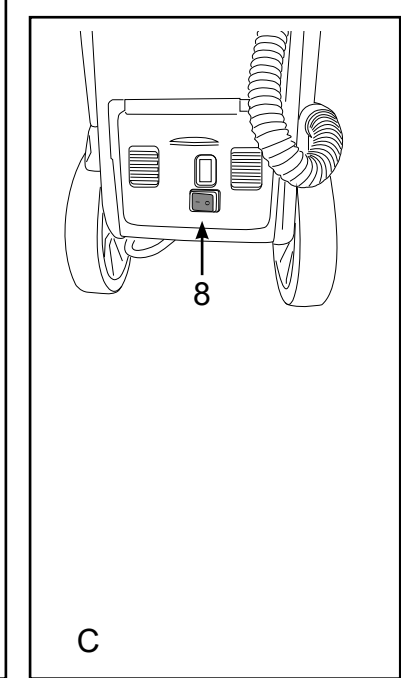
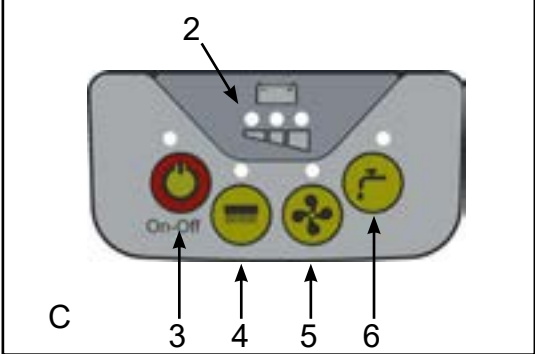
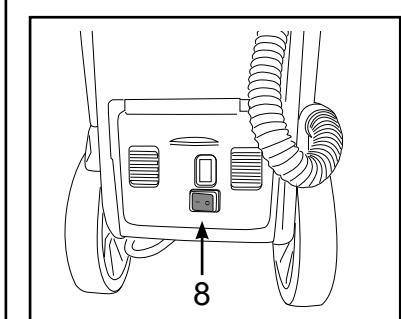
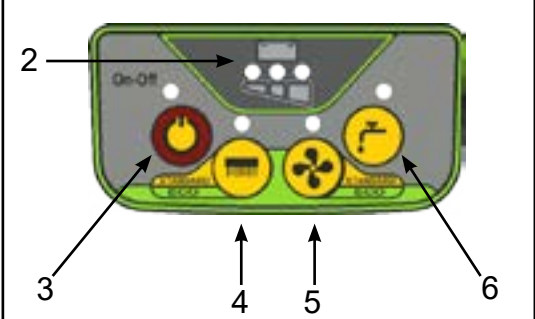
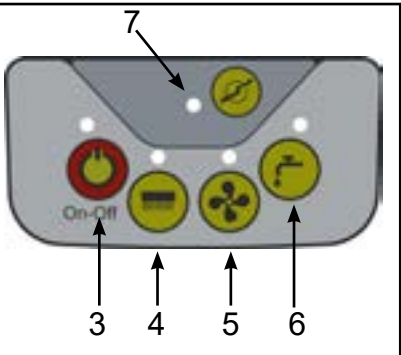
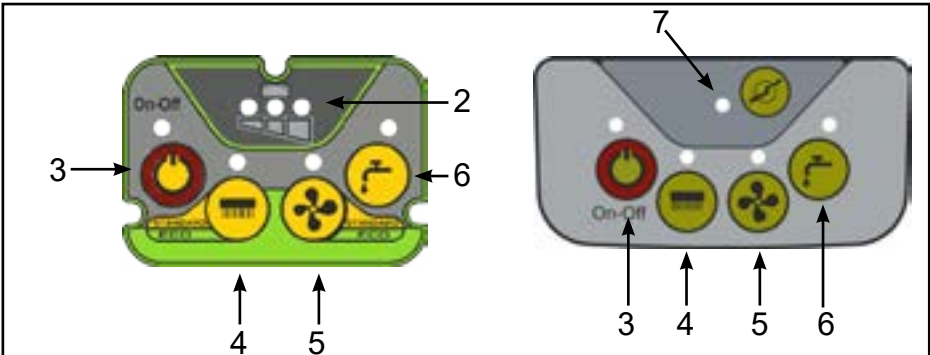
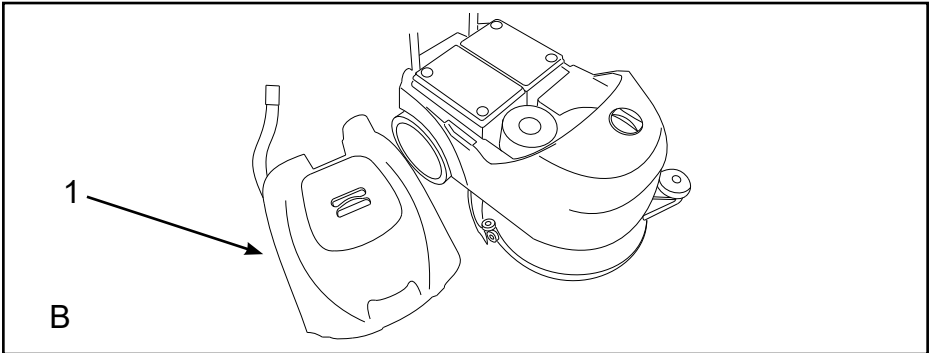

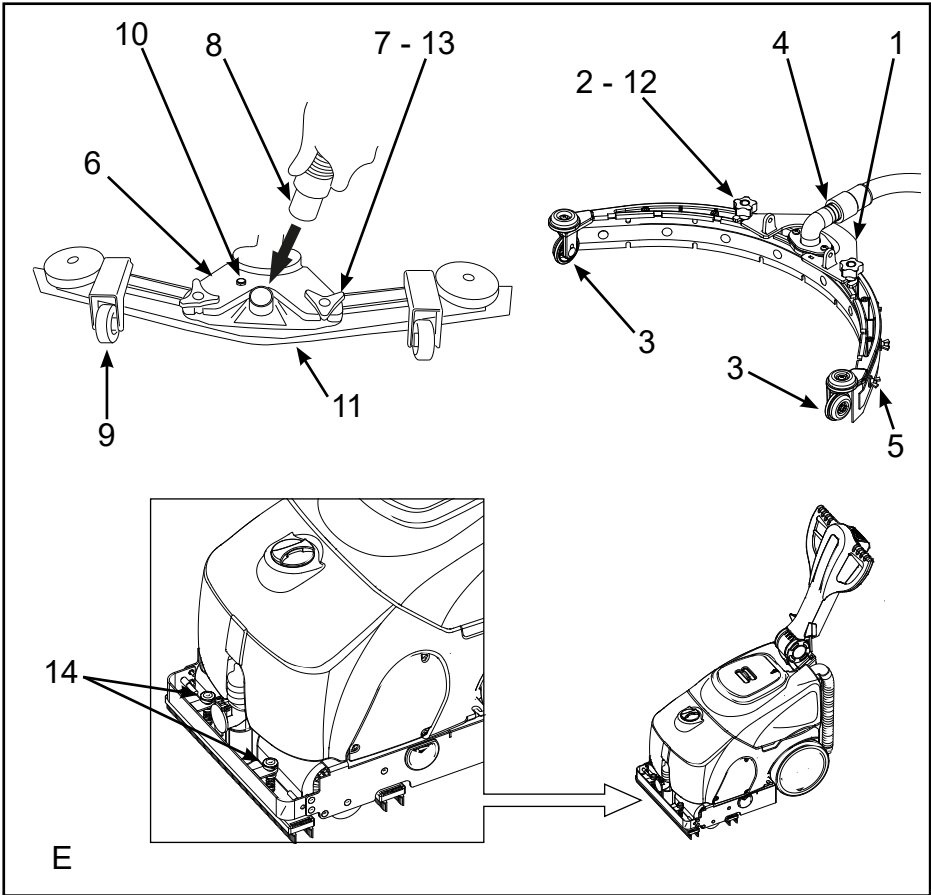
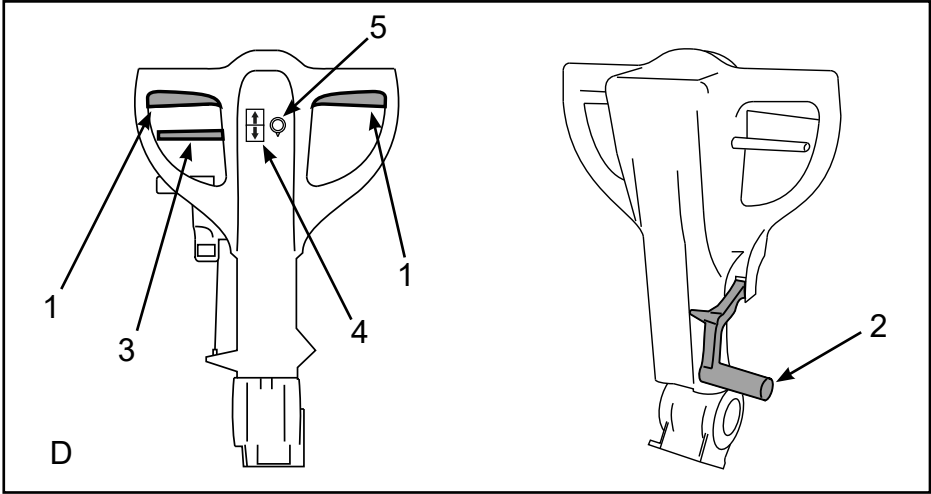

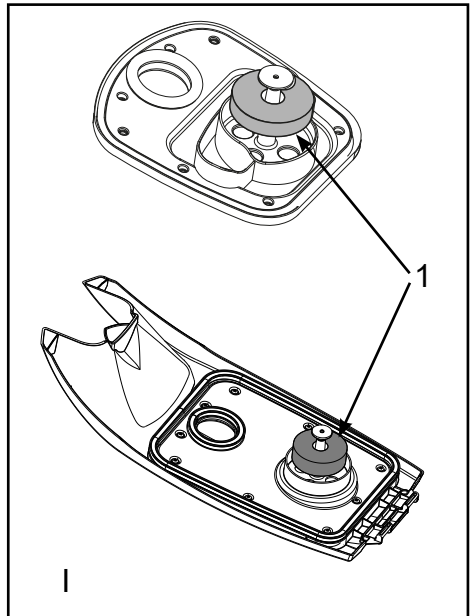
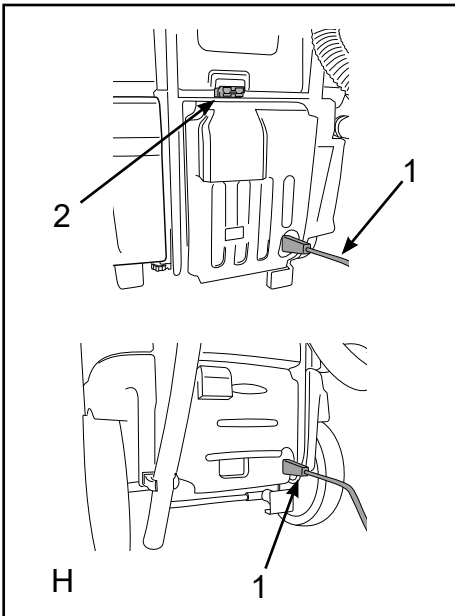
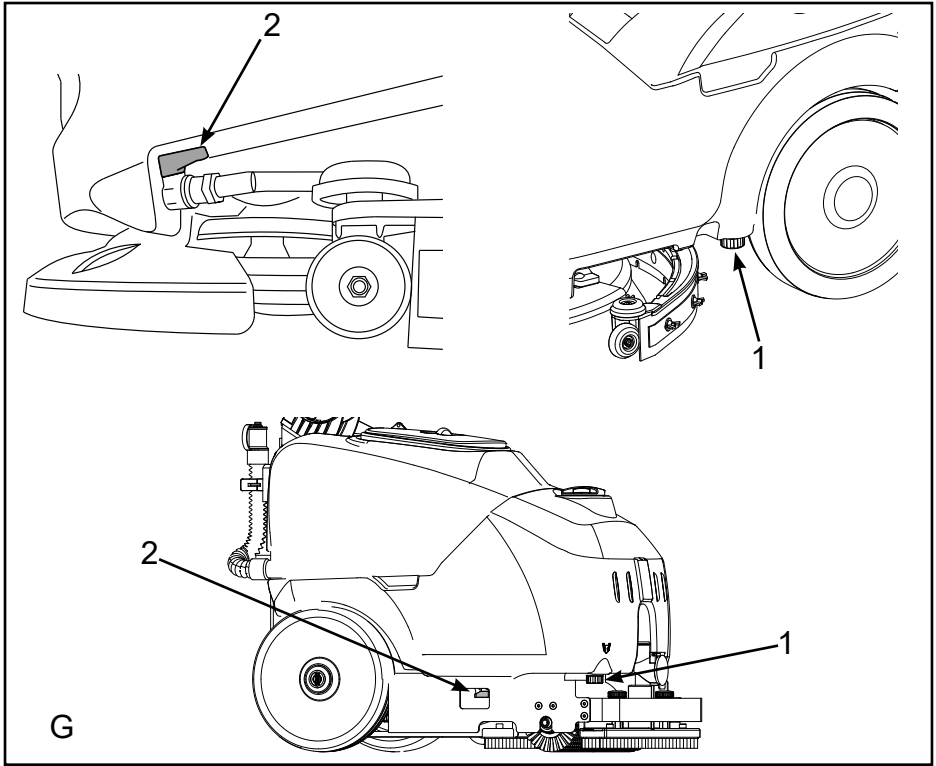

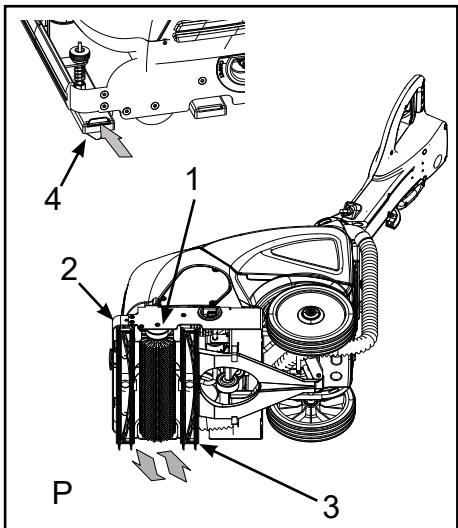
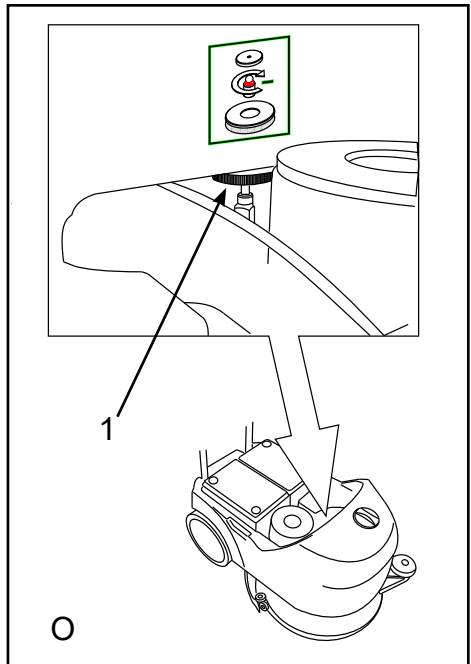
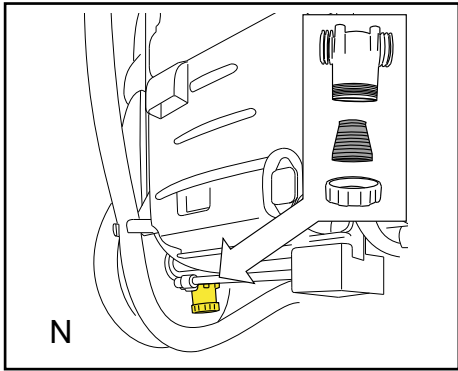
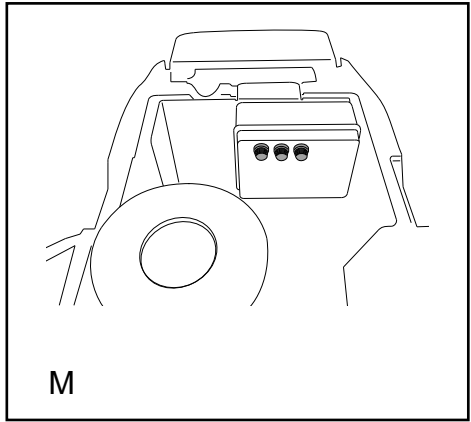
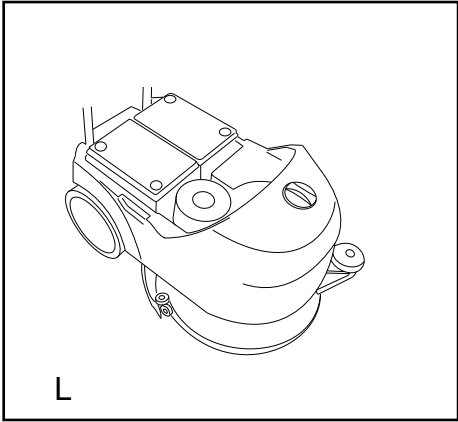

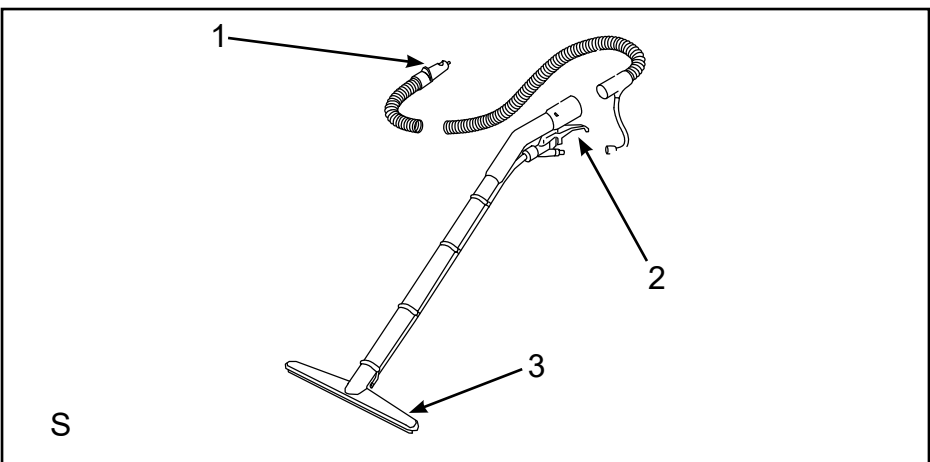
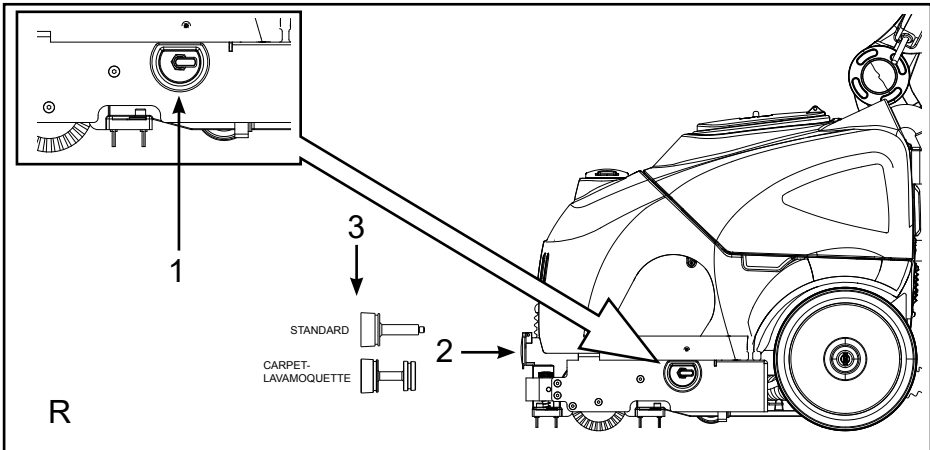
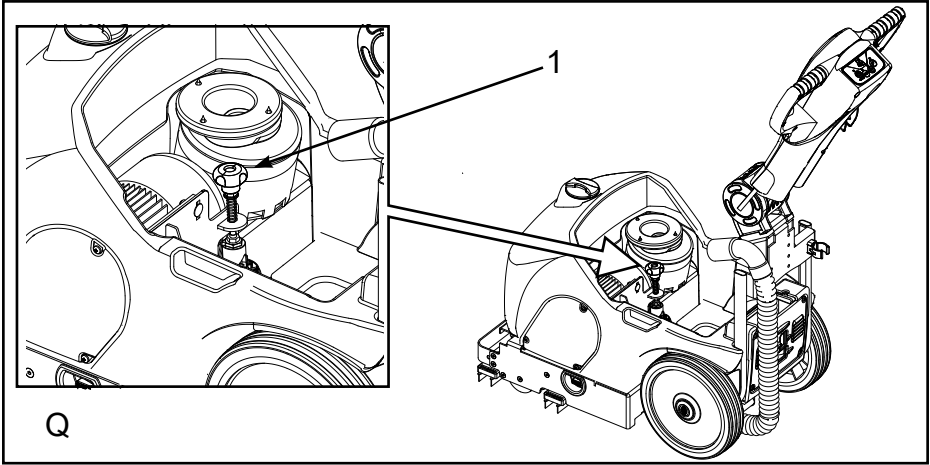

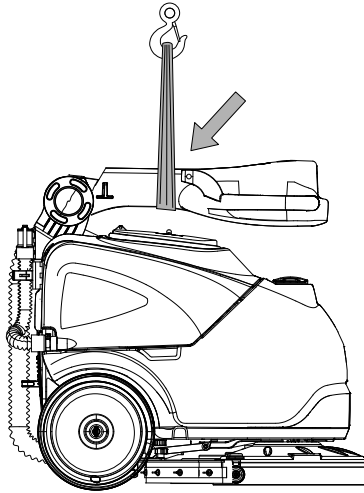

T

GENERAL INFORMATION

INFORMATION

Read this manual carefully before carrying out any work on the machine

Scope of the manual

This manual has been written by the Manufacturer and is an integral part of the machine¹.

It defines the purpose for which the machine has been designed and constructed and contains all the information required by operators².

In addition to this manual, which contains information for operators, other publications are available providing specific information for maintenance personnel³.

The terms "right" and "left", "clockwise" and "anti-clockwise" refer to the forward movement of the machine.

Constant compliance with the instructions provided in this manual guarantees the safety of the operator and the machine, ensures low running costs and high quality results and extends the working life of the machine. Failure to follow these instructions may lead to injury to the operator or damage to the machine, floor and environment.

Consult the table of contents at the beginning of the manual to find the section you need rapidly.

Parts of the text requiring special attention are printed in bold and preceded by the symbols illustrated and described here.

DANGER

Indicates the need for attention in order to avoid a series of consequences which could cause death or damage to the health of the operator.

IMPORTANT

Indicates the need for attention in order to avoid a series of consequences which could cause damage to the machine or work environment or financial loss.

INFORMATION

Particularly important instructions.

In line with the company's policy of constant product development and updating, the Manufacturer reserves the right to make modifications without warning.

Although your machine may differ appreciably from the illustrations in this document, safety and the information contained in this manual are guaranteed.

Identifying the machine

The rating plate provides the following information:

- ▶ Name of manufacturer.
- ▶ Model
- ▶ Serial number.
- ▶ Year of manufacture.
- ▶ Power supply voltage (charging/supply value).
- ▶ Current intensity (charging value).
- ▶ Gross weight.
- ▶ IP degree of protection.
- ▶ Machine voltage (in average operating conditions)
- ▶ Machine power (in average operating conditions)
- ▶ Maximum negotiable gradient.

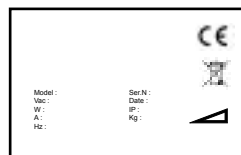

Documentation provided with the machine

- ▶ User manual;
- ▶ guarantee certificate;
- ▶ EC certificate of conformity.

¹ The definition "machine" replaces the trade name covered by this manual.

² Persons responsible for using the machine without performing any operations requiring precise technical skills.

³ Persons with experience, technical training and a knowledge of legislation and standards, able to perform all the necessary operations and to recognise and avoid possible risks in handling, installation, use and maintenance of this machine.

TECHNICAL INFORMATION

General description

This machine is a scrubber drier for sweeping, washing and drying flat, horizontal, smooth or moderately rough, even and obstacle free floors in civil and industrial premises. It is available in both battery and cable versions to meet all running time and weight requirements.

The scrubber drier spreads a solution of water and detergent in the correct concentration on the floor and then scrubs it to remove the dirt. By carefully choosing the detergent and brushes (or abrasive disks) from the wide range of accessories available, the machine can be adapted to a wide range of combinations of types of floor and dirt. A suction system incorporated in the machine dries the floor after washing by means of the low pressure generated in the dirty water tank by the suction motor. The squeegee connected to the tank collects the dirty water.

Legend

The main parts of the machine are as follows (fig. A):

- ▶ the detergent tank (fig. A, ref. 1): contains and transports the mixture of clean water and detergent;
- ▶ the dirty water tank (fig. A, ref. 2): collects the dirty water picked up from the floor after washing;
- ▶ control panel (fig. A, ref. 3);
- ▶ head assembly (fig. A, ref. 4): the main element is the brush which distributes the detergent solution on the floor and remove the dirt;
- ▶ squeegee assembly (fig. A, ref. 5): wipes and dries the floor by collecting the water.

Danger zones

- ▶ Tank assembly: when using certain detergents, danger of irritation for eyes, skin, mucous membranes and respiratory tract and of asphyxia. Danger represented by the dirt collected from the environment (germs and chemical substances). Danger of crushing between the two tanks when the dirty water tank is replaced on top of the detergent tank.
- ▶ Control panel: danger of short circuit.
- ▶ Bottom of washing head: danger due to brush rotation.
- ▶ Rear wheels: danger of crushing between the wheel and chassis.
- ▶ Battery compartment (in the detergent tank): danger of short circuit between the battery poles and presence of hydrogen during charging.

Accessories

- ▶ Bristle brushes: for washing delicate floors and polishing;
- ▶ Polypropylene brushes: for normal floor washing;
- ▶ Tynex brushes: for removing accumulated stubborn dirt on resistant floors;
- ▶ Drive disks: enable the following disks to be used:
 - ▶ Yellow disks: for washing and polishing marble and similar surfaces;
 - ▶ Green disks: for washing resistant floors;
 - ▶ Black disks: for thorough washing of resistant floors with stubborn dirt.
- ▶ S.P.E. battery charger CBHD1

SAFETY INFORMATION

Safety regulations

INFORMATION

Read the "User Manual" carefully before start-up and use or before performing maintenance or any other work on the machine.

IMPORTANT

Rigorously respect all instructions in the Manual (in particular those relating to danger and important information) and on the safety plates fitted to the machine.

The Manufacturer declines all liability for damage to people or things resulting from failure to observe the instructions.

The appliance must be used exclusively by persons trained in its use and/or who have demonstrated their ability and have been expressly instructed to use the appliance.

The machine must not be used by minors.

The machine must not be used for purposes other than those for which it was expressly designed. Scrupulously respect all safety standards and conditions applicable to the type of building in which the machine is to be operated (eg: pharmaceutical companies, hospitals, chemicals, etc).

Do not use the machine in places with inadequate lighting or explosive atmospheres, on public roads, in the presence of dirt hazardous to health (dust, gas, etc) and in unsuitable environments.

This machine is intended for use in commercial applications, such as hotels, schools, hospitals, factories, shops and offices, or for hire.

The machine is designed for indoor use only. The machine must be kept indoors at all times.

The machine is designed for temperatures of between +4°C and +35°C when in use and between +0°C and +50°C when not in use.

The machine must be used at altitudes below 2000 m.

The machine is designed to work in a humidity of between 0% and 95%.

Never use or pick up flammable liquids or explosives (e.g. petrol, fuel oil, etc), flammable gases, dry dusts, acids and solvents (e.g. paint solvents, acetone etc) even if diluted. Never pick up flaming or incandescent objects.

Never use the machine on slopes or ramps of more than 2%. In the case of slight slopes, do not use the machine transversally, always manoeuvre with care and do not reverse. When transporting the machine on steeper ramps or slopes, take the utmost care to avoid tipping up and/or uncontrolled acceleration. Tackle ramps and/or steps with the front of the machine raised only.

Never park the machine on a slope.

The machine must never be left unattended with the motor or engine on. Before leaving it, turn the motor or engine off, make sure it cannot move accidentally.

Always pay attention to other people, children in particular, present in the place where you are working.

Children must be supervised to make sure they do not play with the appliance.

The appliance is not intended for use by persons (including children) with reduced physical, sensory or mental capabilities, or lack of experience and knowledge, unless they have been given supervision or instruction concerning use of the appliance by a person responsible for their safety.

Never use the machine to transport people or things or to tow things. Do not tow the machine.

Never rest objects of any weight on the machine for any reason.

Never obstruct ventilation and heat dispersion slits.

Never remove, modify or circumvent safety devices.

Numerous unpleasant experiences have shown that a wide range of personal objects may cause serious accidents. Before beginning work, remove jewellery, watches, ties, etc.

The operator must always use personal protection devices - protective apron or overalls, non-slip waterproof shoes, rubber gloves, protective goggles and ear protectors and mask to protect the respiratory tract.

Keep the hands away from moving parts.

Never use detergents other than those specified. Follow the instructions on the relative safety sheet. We recommend keeping detergents out of reach of children. In the event of contact with the eyes, wash immediately with abundant water. If ingested, consult a doctor immediately.

Make sure the power sockets used for the models with cable or battery charger are connected to a suitable earth system and protected by differential thermal solenoid switches.

Make sure the electrical characteristics of the machine (voltage, frequency, absorbed power) given on the rating plate are the same as those of the mains electricity supply. The machine with cable has a three-wire cable and a three pin earthed plug for use in an appropriate earthed socket. The earth wire is yellow and green. Never connect this wire to anything other than the earth contact of the socket.

Battery charger: check the power cable regularly for damage; if the power cable is damaged, do not use the charger. To replace the cable, contact a specialist service centre.

To recharge the batteries, always use the battery charger supplied with the machine.

It is indispensable to respect the battery manufacturer's instructions and current legislation. The batteries should always be kept clean and dry to avoid surface leakage current. Protect the batteries from impurities such as metal dust.

Never rest tools on the batteries as this could cause short circuit and explosion.

When using battery acid, always follow the relative safety instructions scrupulously.

When using cable models, take care not to crush or pull the power supply cable.

While using the machine, make sure the rotating brush does not come in contact with the power cable (cable powered version).

Check the power cable regularly. If damaged, do not under any circumstances use the machine. Replace it with one of the same type or contact a specialised service centre (cable powered version).

In the presence of particularly strong magnetic fields, assess the possible effect on the control electronics.

Never wash the machine with water jets.

The fluids collected contain detergent, disinfectant, water and organic and inorganic material. They must be disposed off in accordance with current legislation.

In the case of malfunction and/or faulty operation, turn the machine off immediately (disconnecting it from the mains power supply or removing the fuse from the battery bridge). Do not tamper with it otherwise. Contact a service centre authorised by the Manufacturer.

All maintenance operations must be performed in an adequately lit place and only after disconnecting the machine from the power supply (in cable models, unplug the machine from the mains power socket, in battery models, remove the fuse from the battery bridge). In cable models, the operator must always be in a position to verify that the plug remains unplugged from the mains power socket throughout maintenance operations.

All work on the electrical system and all maintenance and repair operations other than those explicitly described in this manual must be performed by specialised personnel expert in the sector only.

Cleaning and maintenance operations that can be performed by the user must not be entrusted to children unless under supervision.

If the power cable, plug or terminals require replacing, make sure the electrical connections and cable grip are tightly fastened to guarantee the resistance of the cable if pulled. Only original accessories and spare parts supplied by the Manufacturer may be used in order to guarantee safe problem-free operation of the machine. Never use parts removed from other machines or from other kits.

This machine has been designed and constructed to provide ten years' service from the fabrication date shown on the rating plate. After this time, whether the machine has been used or not, it should be disposed of according to current legislation in the country in which it is used:

the machine must be disconnected from the power supply, emptied of liquids and cleaned;

the product is classified as WEEE type special waste and is covered by the requisites of the new environmental protection regulations (2002/96/EC WEEE). It must be disposed of separately from ordinary waste in compliance with current legislation and standards.



Special waste. Do not dispose of with ordinary waste.

Alternatively the machine must be returned to the Manufacturer for a complete overhaul.

If you decide to stop using the machine, you are recommended to remove the batteries and dispose of them at an authorised collection centre.

You should also make sure that all parts of the appliance which could represent a hazard, particularly to children, are made safe.

HANDLING AND INSTALLATION

Lifting and transporting the packaged machine

IMPORTANT

During all lifting operations, make sure the packaged machine is firmly anchored to avoid it tipping up or being accidentally dropped.

Always load/unload lorries in adequately lit areas.

The machine, packaged on a wooden pallet by the Manufacturer, must be loaded using suitable equipment (see EC Directive 2006/42 and subsequent amendments and/or additions) onto the transporting vehicle. At destination, it must be unloaded using similar means.

A fork lift truck must always be used to lift the packaged body of the machine. Handle with care to avoid knocking

or overturning the machine.

Checks on delivery

When the carrier delivers the machine, make sure the packaging and machine are both whole and undamaged. If the machine is damaged, make sure the carrier is aware of the damage and before accepting the goods, reserve the right (in writing) to request compensation for the damage.

Unpacking

IMPORTANT

When unpacking the machine, the operator must be provided with the necessary personal protection devices (gloves, goggles, etc) to limit the risk of accident.

Unpack the machine as follows:

- ▶ cut and remove the plastic straps using scissors or nippers;
- ▶ open the packaging;
- ▶ remove the bags included in the packaging and check the contents:
 - ▶ guarantee slip;
 - ▶ use and maintenance manual;
 - ▶ battery bridges with terminals (battery model only);
 - ▶ battery charger connector (battery models only);
- ▶ remove the machine (CT15 B35) from its packaging, lifting it at the handle folded forwards in the position indicated in the figure (Fig. T), using a strap and a hoist. When lifting, make sure that the machine remains stable in the horizontal position. Take the machine (CT15 B35R, CT30, CT45 and CT46) off the pallet, using a ramp;
- ▶ clean the outside of the machine in respect of safety regulations;
- ▶ after unpacking the machine, install the batteries (battery models) or connect the electrical connections (cable models). See relevant sections.

The packaging may be kept as it can be reused to protect the machine if it is moved to another site or to a repair workshop.

Otherwise it must be disposed off in compliance with current legislation.

Electrical connections and earth (cable models)

The electrical characteristics of the machine are given on the rating plate. Make sure the frequency and voltage correspond to those of the mains supply where the machine will be operated. As far as voltage is concerned, models where the rating plate specifies a voltage of 230 V can be used with voltages of between 220 V and 240 V. Similarly, models rated at 115 V can be used at between 110 V and 120 V. The frequency on the plate must always correspond to the mains voltage.

IMPORTANT

Make sure the mains circuit is suitably earthed and that the sockets (and any adaptors used) ensure the continuity of the earth conductors.

DANGER

Failure to observe these instructions could cause possibly serious damage to people and things and invalidates the guarantee.

Power supply batteries (battery models)

Two different types of battery may be installed on these machines:

- ▶ tubular leak-proof batteries: the electrolyte level must be checked regularly. When necessary, top up with distilled water until the plates are covered. Do not over fill (5 mm max. above the plates).
- ▶ gel batteries: this type of battery requires no maintenance.

The technical characteristics must correspond to those indicated in the paragraph on the technical specification of the machine. The use of heavier batteries could seriously jeopardise manoeuvrability and lead to the brush motor overheating. Batteries with a lower capacity and weight will require charging more frequently.

They must be kept charged, dry and clean and the connections must be tight.

Batteries: preparation

INFORMATION

Installation and connection / removal of the batteries must be carried out by an IPC-approved technician (hereinafter referred to as qualified personnel).

DANGER

During installation of the batteries or any type of battery maintenance, the skilled technician must be provided with the necessary personal protection devices (gloves, goggles, overalls, etc) to limit the risk

of accidents. Keep away from naked flames, do not short circuit the battery poles, do not generate sparks and do not smoke

The batteries are normally supplied filled with acid and ready for use.

If the batteries are dry, before mounting them on the machine, proceed as follows:

- ▶ remove the caps and fill all elements with specific sulphuric acid solution until the plates are entirely covered (this requires at least a couple of passes for each element);
- ▶ leave for 4-5 hours to allow the air bubbles to come to the surface and the plates to absorb the electrolyte;
- ▶ make sure the level of electrolyte is still above the plates and if necessary top up with sulphuric acid solution;
- ▶ close the caps;
- ▶ mount the batteries on the machine (following the procedure described below).

Before starting up the machine for the first time, charge the batteries as follows.

Batteries: installation and connection

DANGER

Check that all switches on the control panel are in the “0” (off) position.

Make sure you connect the terminals marked with a “+” to the positive poles of the battery. Do not check the battery charge by sparking.

Meticulously follow the instructions given below as short circuiting the batteries could cause them to explode.

- ▶ Make sure the dirty water tank is empty and empty if necessary (see relevant paragraph).
- ▶ Remove the dirty water tank (fig. B, ref. 1) off the detergent tank by pulling it upwards, making sure you have previously removed the suction hose and dirty water tank drain hose from their housings.
- ▶ Place the batteries in the battery compartment as shown in the drawing on the dirty water tank.

IMPORTANT

Mount the batteries on the machine using lifting means suitable for their weight.

The positive and negative poles have different diameters.

- ▶ Connect the battery wiring and bridge terminals to the battery poles.
- ▶ Tighten the terminals on the poles and cover with Vaseline.
- ▶ Put the dirty water tank back on the detergent tank.
- ▶ When using the machine, follow the instructions below.

Batteries: removal

DANGER

When removing the batteries, the skilled technician must be equipped with suitable personal protection devices (gloves, goggles, overalls, safety shoes, etc) to reduce the risk of accidents. Make sure the position (off) and the machine is turned off. Keep away from « » switches on the control panel are in the naked flames, do not short circuit the battery poles, do not generate sparks and do not smoke. Proceed as follows

- ▶ disconnect the battery wiring and bridge terminals from the battery poles.
- ▶ if necessary, remove the devices fixing the battery to the base of the machine.
- ▶ lift the batteries from the compartment using suitable lifting equipment.

Battery charger (battery models)

IMPORTANT

Never allow the batteries to become excessively flat as this could damage them irreparably.

INFORMATION

If the machine has an ON-BOARD battery charger (installed by the manufacturer), no operations are required as it will already be ready for use.

Scelta del caricabatteria

Verificare che il caricabatterie sia compatibile con le batterie da caricare.

Batterie tubolari al piombo (WET): è consigliato un caricabatterie elettronico, consultare comunque il fabbricante ed il manuale del caricabatterie per confermare l'idoneità del caricabatterie esterno.

Batterie al gel o AGM: utilizzare un caricabatterie specifico per questo tipo di accumulatori.

! PERICOLO

Utilizzare caricabatteria con marcatura CE, che sia conforme alla norma di prodotto (EN 60335-2-29), dotato di doppio isolamento o isolamento rinforzato tra l'ingresso e l'uscita e con circuito di uscita tipo SELV, con tensione massima di uscita 24 V e corrente massima di ricarica 15 A.

Dati soggetti a variazioni senza preavviso.

Preparing the battery charger

If you wish to use a battery charger not provided with the machine, you must fit it with the connector supplied with the machine (see paragraph "Unpacking" in this manual).

To install the connector, proceed as follows:

- ▶ remove about 13 mm of protective sheath from the red and black wires of the battery charger;
- ▶ insert the wires into the connector contacts and squeeze them forcefully with suitable pliers;
- ▶ respect the polarity (red wire + black wire -) when inserting the wires into the connector.

Lifting and transporting the machine

IMPORTANT

All phases must be performed in an adequately lit room and adopting the safety measures most appropriate to the situation.

The operator must always use personal protection devices.

To load the machine onto a means of transport, proceed as follows:

- ▶ empty the dirty water and detergent tanks;
- ▶ place the machine in the packaging, then rest the packaging on a pallet and fix it with plastic straps;
- ▶ lift the pallet (with the machine) using a fork lift truck and load it onto the means of transport;
- ▶ anchor the machine to the means of transport with cables connected to the pallet and machine itself.

PRACTICAL GUIDE FOR THE OPERATOR

Controls - Description

With reference to fig. C, the machine has the following controls and indicator lights:

- ▶ Power on light (fig. C, ref. 7 - cable model only): green, indicates that the machine's power cable is connected to the mains.
- ▶ Battery charge light (fig. C, ref. 2 - battery models only): 3 LEDs (red, yellow and green) which indicate the level of battery charge. There may be:
 - ▶ red and green LEDs on, yellow LED flashing: battery voltage > 30.0 V;
 - ▶ red, yellow, green LEDs on: battery voltage from 30.0-23.3 V;
 - ▶ red, yellow LEDs on: battery voltage from 23.5-22.5 V;
 - ▶ red LED on: battery voltage from 22.5-21.9 V;
 - ▶ red LED flashing: battery voltage from 21.9-21.4 V, batteries completely discharged; after a few seconds the brush and suction motor shut down;
 - ▶ red, yellow, green LEDs flashing, ECS model and Roller model, excessive brush motor current draw, excessive head pressure on working surface.
- ▶ Instrument panel main switch - (Fig. C, ref. 3): connects (LED on) and disconnects (LED off) power to all the machine's functions (to turn the machine off, hold the button down for at least 4 seconds). In the BT version, the LED flashes during operation.
- ▶ Main switch - (Fig. C, ref. 8 - cable model only): connects and disconnects power to all the machine's functions.
- ▶ Brush button with light (fig. C, ref. 4): enables (LED on) and disables (LED off) the "brush" function. The brush does not start rotating until the brush lever is operated. ECO function (battery models only), used to reduce brush motor power by 20%, to activate this function, operate the "Brush lever" then press the button for a few seconds, until the LED starts flashing.

i INFORMATION

When the brush button is pressed, suction and detergent delivery are also enabled automatically.

- ▶ Suction button with light (Fig. C, ref. 5): switches on ("LED on") and off ("LED off") the suction motor to dry the floor being washed. The light is on when there is power to the suction motor. ECO operation (battery models only), used to reduce suction motor power by 20%, to activate this function, operate the "Brush lever" then press the button for a few seconds, until the LED starts flashing. Suction can be activated without operating the brush control lever, by holding the button for a few seconds until the LED starts flashing; detergent delivery can also be activated by pressing the button (Fig. C, ref. 6).
- ▶ Detergent button (Fig. C, ref. 6): enables ("LED on") and disables ("LED off") detergent delivery. Detergent is only delivered when the brush is rotating. To enable high pressure delivery, use the CARPET accessory (battery model only), activate the "brush control lever", press the detergent button for at least 3 seconds (Fig. C, ref. 6), the LED will start flashing, the pump will deliver detergent at high pressure; to restore standard delivery pressure, press the button for at least 3 seconds.
- ▶ Brush lever (fig. D, ref. 1): enables brush rotation.
- ▶ Squeegee lever (fig. D, ref. 2): raises (if lowered) or lowers (if raised) the squeegee.
- ▶ Handle regulation lever (fig. D, ref. 3): allows the angle of the handle to be adjusted.
- ▶ Head pressure adjustment knob, ECS model (fig. O, ref. 1): turn the knob clockwise to reduce the pressure of the microfibre on the work surface; turn the knob anticlockwise to increase the pressure of the microfibre on the work surface. To access the knob, remove the dirty water tank from the detergent tank.
- ▶ Brush roller pressure adjustment knob, roller model (Fig. Q, ref. 1): turning the knob adjusts the working height of the brush roller; to access this device, remove the dirty water tank from the solution tank.
- ▶ Speed potentiometer (fig. D, ref. 5, models with electric drive): regulates the machine's forward or reverse speed.
- ▶ Direction buttons (fig. D, ref. 4, models with electric drive): press these buttons to set movement of the machine to forward or reverse.
- ▶ CARPET/FLOOR operation selector (Fig. R, ref. 1): when installed, selects the machine operating mode, FLOOR or CARPET.
- ▶ Detergent tap (Fig. G, ref. 2): adjusts the flow of detergent delivered to the brush.

Mounting and adjusting the squeegee

The squeegee (fig. A, ref. 5) is responsible for the first phase of drying.

Depending on the type of squeegee mounted on the machine, follow the instructions below to install:

Parabolic squeegee

To mount the squeegee on the machine, proceed as follows:

- ▶ check that the squeegee mount (fig. E, ref. 1) is lowered, otherwise lower it by means of the squeegee lever (fig. D, ref. 2);
- ▶ rotate the machine backwards and rest the handle on the floor;
- ▶ insert the two threaded pins (fig. E, ref. 12) on the squeegee into the slots on the support (fig. E, ref. 1);
- ▶ fix the squeegee by tightening the two knobs (fig. E, ref. 2);
- ▶ insert the sleeve of the suction hose (fig. E, ref. 4) fully into the squeegee;

The squeegee blades scrape the film of water and detergent from the floor and prepare the way for perfect drying. With time, the constant rubbing makes the edge of the blade in contact with the floor rounded and cracked, reducing the drying efficiency and requiring it to be replaced. The state of wear should be checked frequently.

For perfect drying, the squeegee must be adjusted in such a way that the edge of the rear blade bends during operation by about 45° with respect to the floor at every point. Adjust the height of the blade during operation by regulating the height of the wheels positioned behind and alongside the squeegee (fig. E ref. 3).

"V" squeegee

- ▶ check that the squeegee mount (fig. E, ref. 6) is lowered, otherwise lower it by means of the squeegee lever (fig. D, ref. 2);
- ▶ insert the two threaded pins (fig. E, ref. 13) on the squeegee into the slots on the support (fig. E, ref. 6);
- ▶ fix the squeegee by tightening the two knobs (fig. E, ref. 7);
- ▶ insert the sleeve of the suction hose (fig. E, ref. 8) fully into the squeegee;

The squeegee blades scrape the film of water and detergent from the floor and prepare the way for perfect drying. With time, the constant rubbing makes the edge of the blade in contact with the floor rounded and cracked, redu-

cing the drying efficiency and requiring it to be replaced. The state of wear should be checked frequently. For perfect drying, the squeegee must be adjusted in such a way that the edge of the rear blade bends during operation by about 45° with respect to the floor at every point. Adjust the height of the blade during operation by regulating the height of the wheels positioned on the squeegee (fig. E ref. 9). The slope of the squeegee can also be varied by tightening or loosening the screw (fig. E, ref. 10).

Moving the machine when not in operation.

Roller version

The squeegee blades scrape the film of water and detergent from the floor and prepare the way for perfect drying. With time, the constant rubbing makes the edge of the blade in contact with the floor rounded and cracked, reducing the drying efficiency and requiring it to be replaced. The state of wear should be checked frequently. The machine is fitted with two squeegees, for washing and drying when moving both forwards and backwards. The squeegees feature a pressure adjustment system to adapt them to all types of surface. Pressure is adjusted by turning the knob provided (Fig. E, ref. 14):

- ▶ clockwise increases the pressure.
- ▶ anticlockwise decreases the pressure.

To move the machine, proceed as follows:

- ▶ lift the squeegee using the lever provided (Fig. D, ref. 2) for parabolic squeegee and "V" squeegee;
- ▶ raise the front of the machine off the floor using the handle, then move it to the destination; if the transport wheel is fitted, lift the machine using the handle (standard on the roller version) so that it rests on the wheel.
- ▶ on arrival, lower the front of the machine.

Mounting and changing the brush/drive disks

DANGER

During brush/drive disk attachment and release, beware of brush rotation.

IMPORTANT

Never work without the brushes and drive disks correctly installed.

Standard version with brushes and drive disks

Brush/drive disk attachment: turn the machine on by pressing the main switch (fig. C, ref. 3) (LED on), then press the brush button (fig. C, ref. 4 (LED on)). Rest the brush on the floor in front of the machine. Raise the front of the machine by levering on the handle, then lower it onto the brush, centring it with the brush cover. Operate the brush lever (fig. D, ref. 1) repeatedly until the brush automatically engages on the flange hub. If the manoeuvre is not successful, press on the handle again and repeat the centring and repeated operation of the brush lever.

Brush/drive disk release: turn the machine on by pressing the main switch (fig. C, ref. 3) (LED on), then press the brush button (fig. C, ref. 4 (LED on)).

Raise the front of the machine by levering on the handle, then operate the brush lever (fig. D, ref. 1) repeatedly. After a few pulses, the brush (or drive disk) is released and falls to the ground.

Roller version

Attaching the brush roller:

- ▶ switch the machine off, unplug the cable version from the power socket;
- ▶ raise the front of the machine by hand;
- ▶ with the other hand, insert the brush and push it upwards until it is correctly in position (Fig. P, ref. 1);
- ▶ lower the machine

Releasing the brush roller:

- ▶ switch the machine off, unplug the cable version from the power socket;
- ▶ raise the front of the machine by hand;
- ▶ with the other, remove the brush by pulling it downwards (Fig. P, ref. 1);
- ▶ lower the machine.

Detergents - Instructions

IMPORTANT

Always dilute the detergent according to the manufacturer's instructions. Do not use sodium hypochlori-

te (bleach) or other oxidants, particularly in strong concentrations. Do not use solvents or hydrocarbons. The temperature of the water and detergent must not exceed the maximum indicated in the technical specification. They must be free of sand and/or other impurities.

The machine has been designed for use with low-foam biodegradable detergents made specifically for scrubber driers.

For a complete and up-to-date list of the detergents and chemicals available, contact the Manufacturer.

Use products suitable for the floor and dirt to be removed only.

Follow the safety regulations on use of detergents given in the section "Safety regulations".

Preparing the machine for work

IMPORTANT

Before starting work, wear overalls, ear protectors, non-slip waterproof shoes, mask to protect the respiratory tract, gloves and all other personal protection devices recommended by the supplier of the detergent used or necessitated by the work environment.

Before starting work, proceed as follows:

- ▶ Battery models: check the battery charge (charge if necessary);
- ▶ make sure the dirty water tank (fig. A, ref. 2) is empty. If necessary, empty it;
- ▶ via the opening at the front, fill the detergent tank (fig. A, ref. 8) with a suitable concentration of clean water and low-foam detergent. Leave at least 5 cm between the surface of the liquid and the opening of the tank;
- ▶ mount the most suitable brushes or drive disks for the floor and work to be performed (see paragraph 3.4);
- ▶ make sure that the squeegee is securely attached, connected to the suction hose; make sure that the front and rear blades are not worn.
- ▶ adjust the squeegee working height.
- ▶ roller version, adjust the brush roller working height, turning the corresponding knob (Fig. Q, ref. 1); the adjustments must be made with the machine in operating mode (transport wheel disengaged), with the power cable unplugged (cable model) from the mains power supply, or with the machine off, for battery models.

i INFORMATION

If you are using the machine for the first time, we recommend trying it on a large obstacle-free surface first to acquire the necessary familiarity.

Always empty the dirty water tank before filling the detergent tank again.

For effective cleaning and to extend the working life of the machine, follow a few simple rules:

- ▶ prepare the work area by removing all possible obstacles;
- ▶ begin working from the furthest point to avoid walking on the area you have just cleaned;
- ▶ choose the straightest possible working routes;
- ▶ divide large floors into parallel rectangular sections.

If necessary, finish off by passing a mop or rag rapidly over parts inaccessible to the scrubber drier.

Working

After setting up the machine, proceed as follows.

- ▶ Connect the machine as follows:
 - ▶ cable model: plug the machine into the mains power socket;
- ▶ lower the squeegee using the lever provided (Fig. D, ref. 2), standard version with brushes and drive disks;
- ▶ press the main switch (fig. C, ref. 3) (LED on);
- ▶ press the brush button (fig. C, ref. 4) "LED on", this will also automatically activate suction and solution flow. To extend machine operating time, the ECO function can be activated (see the paragraph "Controls - Descriptions");
- ▶ select the direction of movement by pressing the button (fig. D, ref. 4) (models with electric drive)
- ▶ adjust the forward/reverse speed by turning the potentiometer (fig D, ref. 5) (models with electric drive)
- ▶ press the brush lever (fig. D, ref. 1);

- ▶ check regularly that detergent is reaching the brushes and top up if necessary;
- ▶ while working, check the quality of washing and adjust the flow of detergent to the brushes using the detergent tap (fig. G, ref. 2), in the ECS model, the detergent tap must always be fully open.

IMPORTANT

Empty the dirty water tank each time you fill the detergent tank.

- ▶ The float switch in the dirty water tank (fig. I, ref. 1) turns suction off when the tank is full. If the switch trips, stop work and empty the tank;
- ▶ Battery models: if the red LED (fig. C, ref. 2) starts flashing, the batteries are nearly flat. After a few seconds, the brush and suction motor shut down to prevent draining the batteries excessively. Charge the batteries.
- ▶ ECS model and Roller model: when working, make sure that the microfibre or roller pressure on the working surface is within the allowed operating range. If during operation the battery charger control lights (Fig. C, ref. 2 - battery models only) start flashing, decrease microfibre/roller pressure by turning the knob (Fig. O, ref. 1) on the ECS version, or the knob (Fig. Q, ref. 1) on the roller version; the adjustments must be made with the power cable unplugged (cable model) from the mains power supply, or with the machine off, for battery models. To access this device, lift the dirty water tank.

At the end of work:

- ▶ release the brush lever (fig. D, ref. 1);
- ▶ turn the machine off by pressing the button (fig. C, ref. 3) for at least 4 seconds.
- ▶ use the lever provided (Fig. D, ref. 2) to raise the squeegee off the floor and prevent continuous pressure from deforming the drying blades, standard version with brushes and drive disks;
- ▶ remove the brush (or drive disk) to prevent it from warping permanently;
- ▶ use the handle to raise the front of the machine and fit the transport wheel, thus preventing continuous pressure from deforming the drying blades and the brush roller, roller version.
- ▶ depending on the model, unplug from the mains socket or disconnect the batteries,
- ▶ empty and clean the dirty water tank.

Some useful tips to get the most from your scrubber drier

In the event of particularly stubborn dirt on the floor, washing and drying can be performed in two separate operations.

Prewashing with brushes or pads

- ▶ press the main switch (fig. C, ref. 3) (LED on);
- ▶ press the brush button (fig. C, ref. 4) (LED on);
- ▶ press the suction button (fig. C, ref. 5) (LED off) to turn suction off;
- ▶ operate the brush lever (fig. D, ref. 1) to enable brush rotation;
- ▶ make sure the suction motor is off and the squeegee is raised;
- ▶ begin washing.
- ▶ adjust the flow of detergent to the brush by means of the detergent tap (fig. G, ref. 2). Flow speed must be regulated according to the operator's chosen advance speed. The slower the machine moves forwards, the less water is needed. Persist when washing particularly dirty points to give the detergent time to perform its chemical action detaching and suspending the dirt and the brushes time to exert an effective mechanical action.

Drying

Lower the squeegee and with the suction motor on, pass over the same area washed previously. The result is equivalent to in-depth washing and subsequent ordinary maintenance will take less time.

To wash and dry at the same time, operate the brush, detergent flow, squeegee and suction motor simultaneously.

Carpet accessory

This accessory comprises a slider that can wash and dry any type of carpet.

Assembly instructions:

- ▶ remove the two squeegees (Fig. P, ref. 2-3) from their housings.

- ▶ insert the slide (Fig. P, ref. 4) in position (Fig. P, ref. 2).
- ▶ lift the cover (Fig. R, ref. 2) and insert the cap (Fig. R, ref. 3) supplied for CARPET operation.
- ▶ close the cover to lock it in position.

Operation:

- ▶ Turn the function selector to the Carpet position (Fig. R, ref. 1).
- ▶ Press the brush button (Fig. C, ref. 4), then with the pump operating, LED on (Fig. C, ref. 6), activate the brush control lever (Fig. D, ref. 1) and press the detergent button (Fig. C, ref. 6) for at least 3 seconds; the LED will start flashing, the pump will deliver detergent at high pressure (BATTERY version only). To restore standard delivery pressure, press the detergent button (Fig. C, ref. 6) for at least 3 seconds.

Start working, the machine must only be used moving backwards.

Combi accessory

The Combi accessory is used for washing in positions that the floor scrubber cannot reach, such as corners, stairs or around obstacles.

To use the accessory, proceed as follows:

- ▶ switch the machine off.
- ▶ lift the cover (Fig. R, ref. 2) and fit the Combi attachment in position (Fig. S, ref. 1) with the hole facing upwards.
- ▶ close the cover (Fig. R, ref. 2) on the Combi attachment to lock it in position.
- ▶ if installed, turn the function selector to FLOOR (Fig. R, ref. 1).
- ▶ activate the suction motor, pressing the suction button (Fig. C, ref. 5) for a few seconds, until the LED starts flashing; detergent delivery can also be activated by pressing the button (Fig. C, ref. 6).
- ▶ holding the accessory, spray the detergent by activating the lever (Fig. S, ref. 2), and rub the floor with the bristles (Fig. S, ref. 3) to remove the dirt.
- ▶ check at all times that the clean water tank is not empty, as operating the pump without water may cause irreparable damage.
- ▶ after having washed the area using the accessory, switch the machine off.

Draining the dirty water

DANGER

Use suitable personal protection devices.

Drain the water with the machine disconnected from the power supply.

The dirty water tank drain hose is at the back of the machine on the right.

To empty the tank:

- ▶ move the machine near a drain;
- ▶ detach the drain hose (fig. A, ref. 7) from its seat by holding it near the fixing spring and pulling horizontally;
- ▶ keeping the end of the hose as high as possible and remove the cap;
- ▶ lower the end of the hose gradually, controlling the intensity of the flow of water by adjusting the height from the ground;
- ▶ check the amount of dirt left in the dirty water tank and if necessary wash it out;
- ▶ close the drain hose with the cap. Check that it is tightly closed and replace the hose in its housing.
- ▶ You are then ready to wash and dry again.

Draining the clean water

DANGER

Use suitable personal protection devices.

Drain the water with the machine disconnected from the power supply.

To empty the tank:

- ▶ move the machine near a drain;
- ▶ unscrew the cap (fig. G, ref. 1);
- ▶ when the detergent tank is completely empty, screw the cap back on (fig. G, ref. 1).

i INFORMATION

The water and detergent solution can also be used to wash the dirty water tank.

PERIODS OF INACTIVITY

If the machine is not used for some time, remove the squeegee and brush (or drive disk), wash them and put them away in a dry place (preferably in a bag or wrapped in plastic film) away from dust.

Make sure the tanks are completely empty and perfectly clean.

Disconnect the machine from the power supply (depending on the model, unplug from the mains or disconnect the connector from the battery wiring).

Battery models: charge the batteries completely before storing them. During long periods of inactivity, you should charge the batteries regularly (at least once every two months) to keep them constantly at maximum charge.

IMPORTANT

If you do not charge the batteries regularly, they may be irrevocably damaged.

BATTERY MAINTENANCE AND CHARGING

DANGER

Do not check the batteries by sparking.

The batteries give off flammable fumes. Put out all fires and hot embers before checking or topping up the batteries.

Perform the operations described above in a ventilated room.

To avoid permanent damage to the batteries, do not run them down completely.

Remember that when the corresponding red light (fig. C, ref. 2) flashes on the control panel, you must charge the batteries.

Charging procedure

- ▶ if the machine does not have an on-board charger (CT46), connect the external battery charger connector to the battery wiring connector (fig. H, ref. 2).
- ▶ if the machine has an on-board battery charger, connect the on-board battery charger power cable (fig. H, ref. 1).

IMPORTANT

In the case of gel batteries, use a charger specific for gel batteries only.

- ▶ Charge the batteries as described in the battery charger manual;
- ▶ at the end of charging, disconnect the connectors;
- ▶ reconnect the battery wiring connector to the machine connector (machine with external battery charger).

MAINTENANCE INSTRUCTIONS

DANGER

Never perform any maintenance operations without first unplugging the machine from the mains (cable version) or disconnecting the fuse on the battery bridge (battery version).

In cable models, the operator must be able to verify from any position that the machine remains unplugged from the mains socket while maintenance is being carried out.

Maintenance of the electrical circuit and all other operations not expressly required by this manual must be performed by specialised personnel only, in compliance with current safety legislation and as described in the maintenance manual.

Maintenance - General rules

Performing regular maintenance according to the Manufacturer's instructions improves performance and extends the working life of the machine.

When cleaning the machine, respect the following:

- ▶ avoid the use of high pressure washers. Water could penetrate the electrical compartment or motors leading to damage or the risk of short circuit;
- ▶ do not use steam to avoid the heat warping plastic parts;
- ▶ do not use hydrocarbons or solvents as they could damage the cowling and rubber parts.

Routine maintenance

Float switch and detergent tank filter: cleaning

- ▶ Remove the dirty water tank cap and clean the float switch (fig. I, ref. 1). Make sure it runs freely on the pin.
- ▶ clean the detergent tank filter (fig. N) by unscrewing the cap and extracting the filter assembly.

Squeegee blades: replacing

The squeegee blades collect the film of water and detergent from the floor and prepare the way for perfect drying. With time, the constant rubbing makes the edge of the blade in contact with the floor rounded and cracked, reducing the drying efficiency and requiring it to be replaced.

Turning or replacing the blades:

Parabolic squeegee

- ▶ lower the squeegee by means of the squeegee lever (fig. D, ref. 2);
- ▶ tip the machine backwards and rest the handle on the floor.
- ▶ remove the suction hose sleeve (fig. E, ref. 4) from the squeegee;
- ▶ remove the squeegee (fig. E ref. 1) from its mount by completely unscrewing the two knobs (fig. E ref. 2)
- ▶ remove the blade retainers and blades by unscrewing the knobs (fig. E, ref. 5);
- ▶ reuse the same blade by reversing the edge in contact with the floor until all four edges are worn out, or replace with a new blade, fitting it onto the screws on the body of the squeegee;
- ▶ replace the two blade retainers and the blades and screw up the knobs unscrewed previously;
- ▶ replace the squeegee in its support following the instructions in the section "Mounting and adjusting the squeegee".

"V" squeegee

- ▶ lower the squeegee by means of the squeegee lever (fig. D, ref. 2);
- ▶ remove the suction hose sleeve (fig. E, ref. 8) from the squeegee;
- ▶ remove the squeegee from its mount (fig. E ref. 6) by completely unscrewing the two knobs (fig. E ref. 7)
- ▶ remove the blade pressing devices by opening the catch (Fig. E, ref. 11)
- ▶ reuse the same blade by reversing the edge in contact with the floor until all four edges are worn out, or replace with a new blade, fitting it onto the screws on the body of the squeegee;
- ▶ reposition the two blade pressing devices and the blades, closing the catch.;
- ▶ replace the squeegee in its support following the instructions in the section "Mounting and adjusting the squeegee".

Roller version

- ▶ remove the two squeegees (Fig. P, ref. 2-3)
- ▶ turn the squeegees over;
- ▶ remove the worn blades by pulling them off, and then replace them with new ones, inserting the protruding tooth into the socket;
- ▶ replace the squeegee on the its support.

Fuses: replacement (battery models) (Fig. L)

- ▶ The fuses protecting the electrical circuit are located in the battery compartment.
- ▶ Fuse table: for the complete fuse table, see the spare parts catalogue.

Fuses: replacement (cable models) (fig. M)

- ▶ The fuses protecting the electrical components are on the electrical components box.
- ▶ Fuse table: for the complete fuse table, see the spare parts catalogue.

IMPORTANT

Never use a fuse with a higher amperage than specified.

If a fuse continues to blow, the fault in the wiring, boards (if present) or motors must be identified and repaired. Have the machine checked by qualified personnel.

Routine maintenance

Daily operations

After each day's work, proceed as follows:

- ▶ disconnect the machine from the power supply;
- ▶ empty the dirty water tank and clean if necessary;
- ▶ clean the squeegee blades and check for wear. If necessary, replace.
- ▶ check that the suction hole in the squeegee is not blocked, if necessary remove encrusted dirt;
- ▶ Battery model: charge the batteries according to the procedure described;

Weekly operations

- ▶ clean the dirty water tank float switch and make sure it is working correctly;
- ▶ clean the suction hose;
- ▶ clean the dirty water tank and detergent tank;

- ▶ Battery model: check the level of battery electrolyte and top up with distilled water if necessary;

Six monthly operations

Have the electrical circuit checked by qualified personnel.

TROUBLESHOOTING

How to resolve possible problems

[B]= battery machines

[C]= cable machines

[CT46] = CT46 battery powered machine with external battery charger

Possible problems affecting the whole machine.

PROBLEM	CAUSE	REMEDY
The machine does not function	[B]= battery connector disconnected	[B]= connect the batteries to the machine
	[B]= the batteries are flat	[B]= charge the batteries.
	[B] [C]= fuse blown	[B] [C]= replace the fuse
	[C]= the machine is not plugged into the mains socket	[C]= plug into the mains socket
	[CT46] = cap (MPVR11961 code) not fitted to Anderson recharge connector	[CT46] = check that the cap (MPVR11961 code) is fitted to the Anderson recharge connector
The brush doesn't rotate	the brush button LED is off	press the brush button
	the LED in the brush button is flashing	reduce the pressure of the microfibre on the work surface
	the brush lever has not been pressed	press the brush lever
	[B] [C] the brush motor thermal cutout has tripped; the motor has overheated	[B] [C] release the brush lever, press the brush button (LED off), leave the machine to cool down for at least 45'
	the power supply or motor thermal cutout connectors are disconnected	reconnect the power supply or motor thermal cutout connectors
	[C]= fuse blown	[B] [C]= replace fuse
	[B]= the batteries are flat	[B]= charge the batteries
the reduction unit is faulty	have the reduction unit replaced	
the motor is faulty	have the motor replaced	
The brush motor has trouble in starting (cable models only)	you are working with a dry brush on a very rough floor	open the detergent tap
	you are working with power cable extensions with an inadequate section, or the voltage is considerably lower than the rated value for the scrubber drier as shown on the rating plate (15% less)	avoid the use of inappropriate extensions. Increase the section of the electric wires and locate sockets with a higher voltage
	the motor is faulty	have the motor replaced
The machine does not clean evenly	the brush or disk is worn	replace
No detergent is delivered	the detergent button LED is off	press the detergent button
	detergent tank empty	fill the detergent tank
	• the brush motor is off	turn the motor on by operating the brush lever
	the hose delivering the detergent to the brush is blocked	unblock and open the circuit
	the tap is dirty or faulty	have the tap cleaned or replaced
	the solenoid valve is faulty	replace the solenoid valve
the filter is dirty	clean the filter	
The detergent flow does not stop	the solenoid valve is faulty	replace the solenoid valve
The suction motor does not start	the suction button LED is off	press the suction button.
	There is no power to the suction motor or the motor is faulty	check that the motor power connector is correctly connected to the main wiring; if it is correctly connected, have the motor replaced

The squeegee does not clean or suction is ineffective	the edge of the rubber blades in contact with the <u>floor is worn</u>	replace the rubber blade
	the squeegee or hose is blocked or damaged	unblock and repair the damage
	the float switch has tripped (dirty water tank), is <u>clogged by dirt or broken</u>	empty the dirty water tank or reset the <u>float switch</u>
	the suction hose is blocked	unblock the hose
	the suction hose is not connected to the squeegee or is <u>damaged</u>	connect or repair the hose
there is no power to the suction motor or the <u>motor is faulty</u>	see: "The suction motor does not start"	

The batteries do not provide the normal work time (battery models only)	the battery poles and charging terminals are <u>dirty and oxidised</u>	clean and grease the poles and terminals. <u>charge the batteries</u>
	the electrolyte level is low	top up all the elements with distilled water <u>as described in the instructions</u>
	the battery charger does not work or is <u>unsuitable</u>	see battery charger instructions
there are considerable differences in density <u>between the various elements of the battery</u>	replace the damaged battery	

The battery discharges too fast during use, even though it has been charged correctly and when tested with a hydrometer at the end of recharging, it turned out to be uniformly charged (battery models only)	the battery is new and does not deliver 100% of its expected capacity	the battery must be "run-in" by performing 20-30 charges and discharges to <u>obtain maximum performance</u>
	the machine is being used at maximum capacity for continuous periods and the working time is <u>not sufficient</u>	if possible, use batteries with a higher capacity or replace the batteries with <u>others charged previously</u>
	the electrolyte has evaporated and does not cover the plates completely	top up all elements with distilled water until the plates are covered then charge <u>the battery</u>

The battery discharges too fast during use, recharging with an electronic battery charger is too fast and after recharging the battery supplies the right voltage (about 2.14V for each element without load), but when tested with a hydrometer is found not to be uniformly charged (battery models only)	the battery supplied filled with acid by the Manufacturer has been stored for too long before being charged and used for the first time	if recharging with a normal battery charger is not effective, you must use a double recharging cycle: - charge it slowly over a 10 hour period at a current of 1/10 the nominal capacity for 5 hours (e.g. for a 100Ah(5) battery the current must be set at 10A, using a manual battery charger); - rest for one hour; - charge it with the normal battery charger.
---	---	---

At the end of charging with the electronic battery charger, the battery does not provide the correct voltage (about 2.14 V per element without load) and appears to be uniformly not charged when tested with a hydrometer (battery models only)	The battery has not been connected to the battery charger (for example, because the low voltage connector of the battery charger has been erroneously connected to the machine <u>connector</u>)	connect the battery charger to the battery connector
	the battery charger and power socket to which the battery is connected are not compatible	check that the power supply characteristics indicated on the battery charger rating plate comply with those of the mains <u>power supply</u>
	the battery charger has not been installed correctly	taking the actual voltage available at the socket into account, make sure that the connections of the primary of the transformer inside the battery charger are correct (consult the battery charger <u>manual</u>)
the battery charger is not working	make sure there is voltage to the battery charger, that the fuses are not blown and that the current reaches the battery; try charging with another rectifier. If the battery charger is not working, contact the technical service centre and indicate <u>the serial number of the battery charger</u>	

At the end of charging with the electronic battery charger, the battery does not provide the correct voltage (about 2.14 V per element without load) and only one or a few elements are found to be discharged when tested with a hydrometer (battery models only)	one or more elements are damaged	replace the damaged elements if possible. For 6 or 12 V single block batteries, replace the entire battery
--	----------------------------------	---

The electrolyte in the battery is turbid (battery models only)	the battery has reached the end of the charging/ discharging cycles declared by the manufacturer	replace the battery
	the battery has been charged with too high a current	replace the battery
	the battery has been charged beyond the limit suggested by the Manufacturer	replace the battery

Error codes displayed, battery version

Brush button LED (Fig. C, ref. 4), 2 fast flashes / pause / 2 fast flashes.	Brush short circuit error.
Brush button LED (Fig. C, ref. 4), 1 flash / pause / 1 flash.	Overcurrent error
Suction button LED (Fig. C, ref. 5), 2 fast flashes / pause / 2 fast flashes.	Suction motor short circuit error
Suction button LED (Fig. C, ref. 5), 1 flash / pause / 1 flash.	Overcurrent error
Brush button LED (Fig. C, ref. 4) + suction button LED (Fig. C, ref. 5), flash in sync / pause / flash in sync.	Electronic board temperature error
Brush button LED (Fig. C, ref. 4), 4 fast flashes / pause / 4 fast flashes.	Brush cut-out error
Yellow battery charger control LED (Fig. C, ref. 2), 7 fast flashes / pause / 7 fast flashes.	Machine on with battery charger powered error, not featured on CT45 BT
Yellow battery charger control LED (Fig. C, ref. 2), 5 fast flashes / pause / 5 fast flashes.	Excessive battery voltage error
Red, yellow, green battery charger control LEDs flashing, (Fig. C, ref. 2)	ECS model and Roller model, excessive brush motor current draw error.



IPC

IP Cleaning S.r.l.
Viale Treviso 63
30026 Summaga di Portogruaro
Venezia (Italy)
T: +39 0421 205511
F: +39 0421 204227
E: www.ipcworldwide.com
W: info@ipcworldwide.com

