

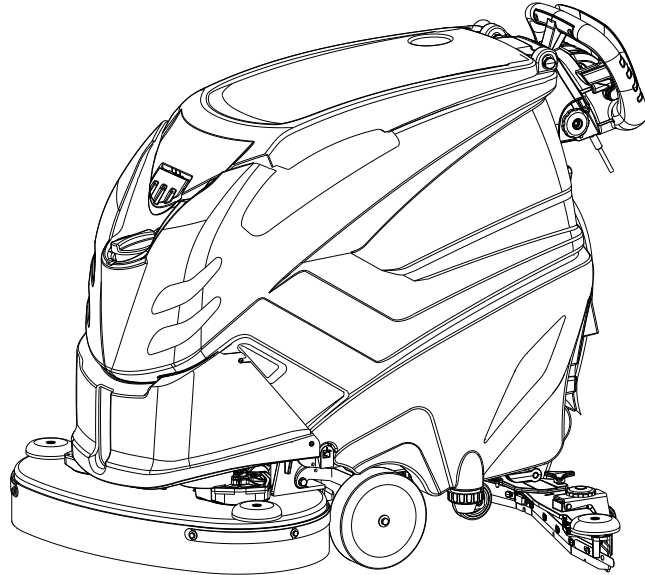

CT51 - CT71

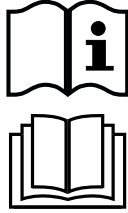

(IT) MANUALE ISTRUZIONI PER L'USO
(EN) OPERATOR'S MANUAL
(FR) MANUEL D'INSTRUCTIONS
(DE) BEDIENUNGSANLEITUNG
(ES) MANUAL DE INSTRUCCIONES
(NO) BRUKERHÅNDBOK
(NL) GEBRUIKERSHANDLEIDING
(PT) MANUAL DE UTILIZAÇÃO
(SE) INSTRUKTIONSBOK
(RU) РУКОВОДСТВО ОПЕРАТОРА
(BG) РЪКОВОДСТВО ЗА ЕКСПЛОАТАЦИЯ
(DK) BETJENINGSMANUAL
(CZ) NÁVOD PRO OBSLUHU
(TR) KULLANIM KILAVUZU

(SL) PRIROČNIK Z NAVODILI ZA UPORABO
(HR) PRIRUČNIK ZA KORIŠTENJE
(HU) HASZNÁLATI ÚTMUTATÓ
(PL) PODRĘCZNIK OPERATORA
(RO) MANUÁLUL OPERATORULUI
(SK) NÁVOD NA POUŽITIE

Consultare attentamente questo manuale prima di procedere a qualsiasi intervento sulla macchina

Read this manual carefully before carrying out any work on the machine

Lire attentivement ce manuel avant toute intervention sur la machine

Vorliegendes Handbuch vor jedem Eingriff an der Maschine aufmerksam durchlesen

Consulte detenidamente este manual antes de llevar a cabo cualquier trabajo en la máquina

Konsulter denne håndbogen nøye før du går i gang med noen som helst type inngrep på maskinen

Raadpleeg deze handleiding aandachtig alvorens met enige werkzaamheid aan de machine te beginnen

Consulte atentamente este manual antes de efectuar cualquier intervención na máquina

Läs noggrant igenom denna handbok innan du utför något som helst ingrepp på maskinen

Прочетете внимателно това ръководство, преди да започнете работа с машината

Внимательно ознакомьтесь с данной инструкцией до проведения любой работы с машиной

Læs denne brugsanvisning omhyggeligt, inden du udfører arbejde på maskinen

Przed jakoukoli manipulacją se strojem si najdříve pozorně přečtete tento návod

Makine ile herhangi bir işlem yapmadan önce bu kılavuzu dikkatle okuyun

Pozorno preberite to navodilo za uporabo, preden se lotite kakršnega koli poseganja v stroj

Pažljivo pročítajte ovaj priručnik prije izvođenja bilo kakvih radnji na uređaju.

A géppel törtéző munkavégzés megelőzően figyelmesen olvassa el ezt az útmutatót

Przed rozpoczęciem pracy z urządzeniem należy uważnie przeczytać niniejszy podręcznik

Citiți cu atenție acest manual înainte de a efectua orice operațiuni asupra mașinii

Tento návod si pozorne přečítajte pred každým zásahom na stroji.

ENGLISH

(Translation of original instructions)

SAFETY INFORMATION	3
Safety precautions	3
TECHNICAL CHARACTERISTICS CT51.....	6
TECHNICAL CHARACTERISTICS CT71.....	8
SAFETY SYMBOLS.....	10
MACHINE DIMENSIONS	10
GENERAL INFORMATION.....	11
Purpose of this manual	11
Identifying the machine	11
Documentation provided with the machine	11
TECHNICAL INFORMATION.....	12
General description	12
Key	12
Hazard areas.....	12
Accessories	12
MOVEMENT AND INSTALLATION	13
Lifting and transporting the packaged machine	13
Delivery checks	13
Unpacking:	13
Batteries (Battery version).....	13
Batteries: preparation.....	14
Batteries: installation and connection.....	14
Batteries: removal	14
Choosing a battery charger	15
Preparing the battery charger	15
respect the polarity (red wire + black wire -) when inserting the wires into the connector.	15
Squeegee installation and adjustment	15
Squeegee adjustment	15
Brush installation.....	16
Lifting and transporting the machine.....	17
Quick head change (BATTERY POWERED VERSIONS ONLY).....	17
PRACTICAL GUIDE FOR THE OPERATOR.....	18
Preparing the machine for work	18
Controls.....	18
Working	20
Some useful tips to get the most from your scrubber drier	20
Emptying the collection tank	21
Emptying the water/detergent tank	21
Emptying the roller head bin	21
Filling the water/detergent tank	21
Filling the Chem-Dose tank (accessory)	21
Finishing work	21
Moving the machine when not in operation.....	21
MAINTENANCE INSTRUCTIONS	22
Maintenance - General rules.....	22
Cleaning the suction motor air filter.....	22
Cleaning the debris container	22
Cleaning the dirty water tank float.....	22
Cleaning the water/detergent tank filter	22
Fuses: replacing.....	23
Battery maintenance and charging	23
Replacing the squeegee blades.....	24
Periodic checks	24
PERIODS OF INACTIVITY	24
TROUBLESHOOTING	25
DISPLAY ALARMS	26
TECHNICAL MENU CT51 - 71.....	27



SAFETY INFORMATION

Safety precautions

! DANGER

Read the “User Manual” carefully before start-up and use or before performing maintenance or any other work on the machine.

! WARNING

Rigorously follow all the instructions in this Manual (in particular those marked “Danger!” and “Warning!”). Also respect the labels applied to the machine (see the “Safety symbols” chapter).

The Manufacturer declines all liability for injury to persons or damage to property resulting from failure to follow instructions.

- ▶ Only one operator may operate the machine.
- ▶ The machine must be used exclusively by persons trained in its use and/or who have demonstrated their ability and have been expressly authorised to use it.
- ▶ The machine must not be used by minors.
- ▶ Always pay attention to other people, especially children, in the place where you are working.
- ▶ Children must be supervised to make sure they do not play with the machine.
- ▶ The machine is not intended for use by persons (including children) with reduced physical, sensory or mental capabilities, or lack of experience and knowledge, unless they are supervised by a person responsible for their safety and have received instruction in the use of the machine.

- ▶ The machine must not be used for purposes other than those for which it was expressly designed.
- ▶ Scrupulously respect all safety standards and conditions applicable to the type of building in which the machine is to be operated (e.g.: pharmaceutical companies, hospitals, chemical companies, etc.).
- ▶ This machine is intended for use in commercial applications, such as hotels, schools, hospitals, factories, shops and commercial premises.
- ▶ The machine must only be used indoors.
- ▶ Warning, the machine must be kept indoors at all times.
- ▶ The machine is designed for use at temperatures of between +4°C and +40°C. When the machine is not being used, the temperature range is +0°C and +50°C.
- ▶ The machine is designed to operate at relative humidity levels between 30% and 95%.
- ▶ The machine must operate at altitudes below 2000 m.

- ▶ When the tank needs to be lifted to access the compartment, its contents must first be emptied, then inserting the safety bracket (fig. 2-ref. 2) in position (fig. 2-ref. 1) to prevent the tank from accidentally closing again.
- ▶ Never use the machine to clean up flammable or explosive liquids (e.g. petrol, fuel oil, etc.), acids or solvents (e.g. paint solvents, acetone etc.) even if diluted.
- ▶ Do not use the machine in inadequate lighting, explosive atmospheres, on public roads, to clean dirt that is hazardous to health (dust, gas, etc.) or in unsuitable environments.
- ▶ Never clean up burning or incandescent objects.
- ▶ Never use to clean on slopes or ramps steeper than those marked on the machine.
- ▶ Never use on slopes or ramps steeper than those marked on the machine..
- ▶ If using the machine on gentle slopes, never drive sideways, rather keep the vehicle parallel to the direction of the slope. Always manoeuvre with care and avoid reversing.
- ▶ Never park the machine on a slope.
- ▶ Never leave the machine unattended with the motor on. Before leaving it, turn the motors off and make sure it cannot move accidentally by disconnecting it from the power supply and removing the electronic key.
- ▶ Never use the machine to transport people or goods or to tow things.
- ▶ Do not tow the machine.
- ▶ Never rest objects of any weight on the machine for any reason.
- ▶ Never obstruct the ventilation and heat dispersion openings.
- ▶ Never remove, modify or circumvent safety devices.
- ▶ Numerous unpleasant experiences have shown that a wide range of personal objects may cause serious accidents. Before beginning work, remove jewellery, watches, ties, etc..

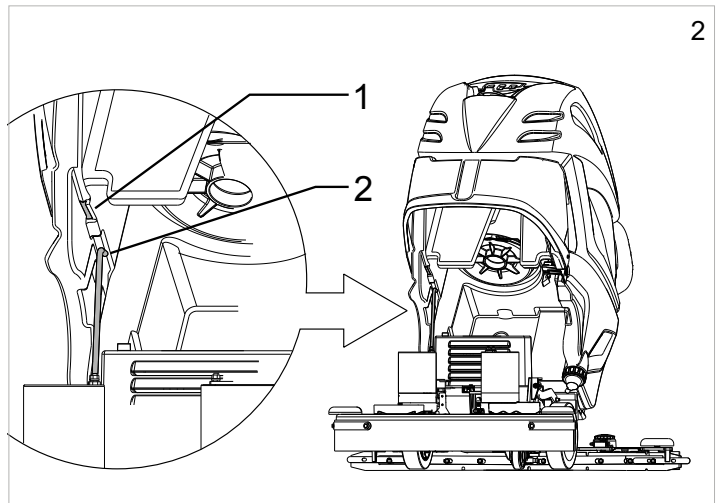

- ▶ The operator must always use personal protection devices: protective apron or overalls, non-slip waterproof shoes, rubber gloves, protective goggles and ear protectors and mask to protect the respiratory tract.
- ▶ When using floor cleaning detergents, follow the instructions and warnings on the product labels.
- ▶ Do not use detergents that may produce hazardous reactions, vapours, heat, etc.
- ▶ Keep hands away from moving parts.
- ▶ Never wash the machine with water jets.

- ▶ Make sure the electrical characteristics of the machine (voltage, frequency, power) given on the nameplate correspond to those of the mains electricity supply.
- ▶ Make sure the power sockets used for battery chargers and mains powered models are properly earthed and protected by a 2-pole thermal magnetic switch with differential circuit-breakers. In the event of a malfunction or failure, the earth connection provides the path of least resistance for electrical current, minimising the risk of electric shock. Mains powered versions come with a three-wire cable and a three-pin earthed plug for use in a suitable earthed socket. The earth wire is yellow and green. Never connect this wire to anything other than the earth terminal of the socket. The plug must be plugged into a suitable socket, correctly installed and wired according to local standards. Incorrect wiring or failure to connect the machine's earth wire may lead to a risk of electric shock. If you are in doubt about the proper earthing of the power socket, have it checked by a qualified electrician. Do not tamper with the plug supplied with the machine. Only use sockets that are suitable for the machine's mains plug. If the plug needs to be replaced, have the job done by a qualified electrician. Use of adapters with the machine's mains power plug is strictly forbidden.
- ▶ Battery charger: check the power cable regularly for damage; if the power cable is damaged, do not use the charger. To replace the cable, contact a specialist service centre.
- ▶ Battery charger, when carrying out maintenance on the machine, disconnect both power supplies (AC and DC).
- ▶ When using cable models:
 - ▶ Make sure to avoid crushing or tearing the power cable, and make sure the rotating brush does not come into contact with the power cable.
 - ▶ Check the power cable regularly. If damaged, do not under any circumstances use the machine. For replacement, contact a specialised service centre.
 - ▶ If the machine does not function as it should or has been dropped, damaged, left outdoors or has fallen in water, have it checked and repaired by a specialist service centre.
 - ▶ Do not move or transport the machine by pulling on its power cable. Do not use the power cable as a handle, close doors on it or pull it over sharp objects or corners. Keep the power cable well clear of hot surfaces.
 - ▶ Do not disconnect the machine by pulling on the power cable. Grip the plug, not the cable, to disconnect the machine.
 - ▶ Never touch a machine with wet hands.
 - ▶ Switch off all controls before unplugging the machine.
 - ▶ To reduce the risk of personal injury caused by the machine's power plug becoming loose in the extension, periodically check that the connection is secure. Using an extension with a loose connection can cause overheating, smoke and even fire. To reduce the risk of the machine's mains power plug becoming loose in the extension, tie a knot as shown (fig. A), or secure the machine's power cable to the clip on the machine's handle as shown (fig. B).

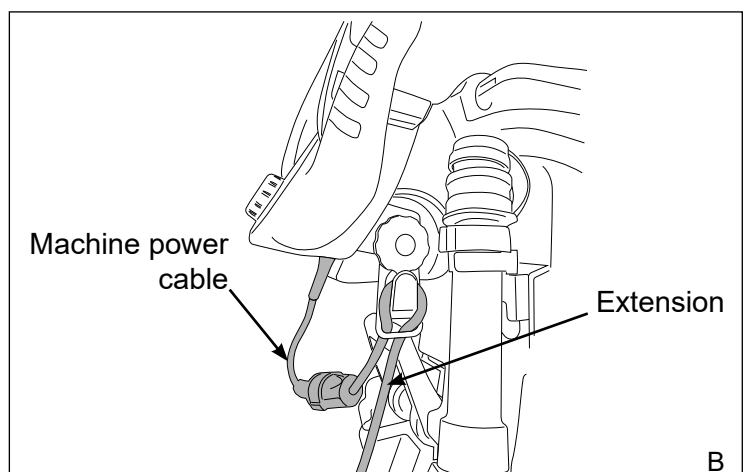
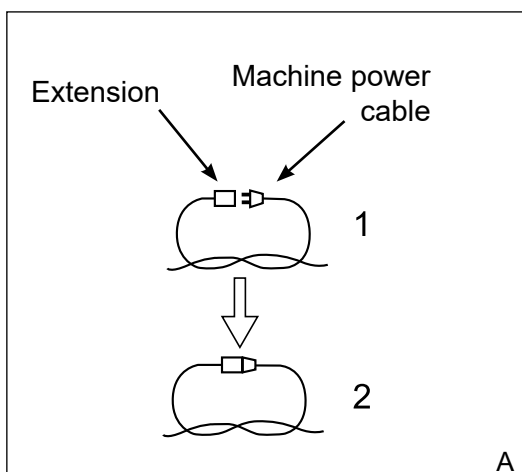

- ▶ In the presence of particularly strong magnetic fields, assess the possible effect on the control electronics.
- ▶ It is indispensable to respect the battery manufacturer's instructions and applicable legislation.
- ▶ The batteries should always be kept clean and dry to avoid surface leakage current.
- ▶ Protect the batteries from impurities such as metal dust.
- ▶ Never rest tools on the batteries as they could cause short circuits leading to explosions.
- ▶ When using battery acid, always follow scrupulously the safety instructions given in the "**Batteries: preparation**" section.
- ▶ If the machine is installed with lead batteries (WET), keep sparks, flames and hot materials away from the batteries. Explosive gases are released during normal operation, in particular when charging.
- ▶ If the machine is installed with lead batteries (WET), highly explosive hydrogen gas is produced when charging the batteries. Lift the tank (insert the safety bracket) during the entire battery charge cycle and only perform the procedure in areas that are well ventilated and far away from naked flames.
- ▶ If deciding to no longer use the machine, it is recommended to remove the batteries and consign them to a waste collection centre, in compliance with environmental safety standards in force.
- ▶ To charge the batteries, always use the battery charger supplied with the machine (if supplied), or one that meets the recommended values shown in the technical specifications.
- ▶ In the event of machine faults and/or malfunctions, switch it off immediately (disconnecting it from the batteries/mains power supply); do not try to repair it, rather contact the manufacturer's service centre.
- ▶ All maintenance operations must be performed in an adequately lit place and only after disconnecting the machine from the power supply, in cable models by unplugging the machine from the socket, in battery models by disconnecting the battery connector; In cable models, the operator must also be able to verify from any position that the machine remains unplugged from the mains socket while maintenance is being carried out.
- ▶ Cleaning and maintenance operations that can be performed by the user must not be entrusted to children unless under supervision.
- ▶ Only use original accessories and spare parts supplied by the Manufacturer to guarantee safe and problem-free operation of the machine.
- ▶ Never use parts removed from other machines or from other kits.

The machine is designed and constructed to provide ten years' service from the date of manufacture shown on the nameplate. After this period, whether the machine has been used or not, it should be disposed of according to current legislation in the country in which it is used.

It should be disconnected from the power supply, emptied of all liquids and cleaned prior to disposal.

The machine is classified as WEEE-type special waste and is covered by the requirements of applicable environmental protection regulations (2002/96/EC WEEE).

The machine must be disposed of separately from ordinary waste in compliance with current legislation and standards.

Also make sure that all parts of the machine that could represent a hazard, particularly to children, are made safe.

Alternatively, return the machine to the Manufacturer for a complete overhaul.

TECHNICAL CHARACTERISTICS CT51

			C50 115V	C55 115V	C50 230V	C55 230V	B50	B55	BT50	BT55	XP50
Cleaning width		mm	496	530	496	530	496	530	496	530	496
Squeegee width		mm	816	816	816	816	816	816	816	816	816
Cleaning capacity per hour		m ² /h	1730	1850	1730	1850	1730	1850	2723	2915	2723
Number of brushes		n°	1	1	1	1	1	1	1	1	1
Brush diameter		mm	496	530	496	530	496	530	496	530	496
Maximum brush pressure		Kg	15,1	14,1	15,1	14,1	11,9	11,2	11,9	11,2	16,8
Brush rotation speed		g/1°	173	173	141/168	141/168	150	150	150	150	150
Brush motor power		W	570	570	570	570	400	400	400	400	400
Drive motor power		W	/	/	/	/	/	/	200	200	200
Suction motor power		W	430	450	430	450	480	480	480	480	480
Overall power of machine in average operating conditions (P _M)		W	690	736	690	736	720	768	960	1008	960
Maximum speed		Km/h	3,5	3,5	3,5	3,5	3,5	3,5	5,5	5,5	5,5
Solution tank		L	49	49	49	49	49	49	49	49	49
Dirty water tank		L	51	51	51	51	51	51	51	51	51
Front wheel diameter		mm	200	200	200	200	200	200	200	200	200
Rear wheel diameter		mm	80	80	80	80	80	80	80	80	80
Maximum slope		%	2	2	2	2	2	2	2	2	2
Gross weight (GVW)		Kg	157	157	157	157	227	227	234	234	234
Weight of the machine in transit without batteries		Kg	102	102	102	102	81	81	89	89	89
Weight of the machine in transit with batteries		Kg	/	/	/	/	169	169	177	177	177
Number of batteries		n°	/	/	/	/	2	2	2	2	2
Machine voltage V _M		V	/	/	/	/	12x2	12x2	12x2	12x2	12x2
Individual battery capacity		Ah (5h)	/	/	/	/	105	105	105	105	105
Supply voltage (battery recharge)	Version without on board battery charger	V	/	/	/	/	24 dc	24 dc	24 dc	24 dc	24 dc
Max current (battery recharge)		A	/	/	/	/	15	15	15	15	15
Mains supply voltage	Mains powered versions with on board charger	V	115V ac 60Hz	115V ac 60Hz	220-240V ac 50-60Hz	220-240V ac 50-60Hz	100-240V ac 50-60Hz	100-240V ac 50-60Hz	100-240V ac 50-60Hz	100-240V ac 50-60Hz	100-240V ac 50-60Hz
Max current (amperes), I		A	9,8	9,8	4,6	4,6	4,1	4,1	4,1	4,1	4,1
Machine dimensions		mm	X=1327 Y=1033 Z=563								
Battery compartment dimensions (length, width, height)		mm	/	/	/	/	360 x 344 x 300				
Packed size (length, width, height)		mm	1365 x 695 x 1146								
Sound pressure - Annex DD (Emission of acoustical noise) EN 60335-2-72: 2012		LpA (dBA)	59	59	58	58	58	58	58	58	58
Measurement uncertainty		K (dBA)	3	3	3	3	3	3	3	3	3
Vibration level (hand) - IEC 60335-2-72		ahv m/sec ²	≤ 2,5	≤ 2,5	≤ 2,5	≤ 2,5	≤ 2,5	≤ 2,5	≤ 2,5	≤ 2,5	≤ 2,5
Measurement uncertainty, k		m/sec ²	/	/	/	/	/	/	/	/	/
Vibration level (body) - IEC 60335-2-72		HBV m/sec ²	/	/	/	/	/	/	/	/	/
Measurement uncertainty, k		m/sec ²	/	/	/	/	/	/	/	/	/
Maximum water and detergent temperature		°C	55	55	55	55	55	55	55	55	55
Protection Grade		IP	IPX3	IPX3	IPX3	IPX3	IPX3	IPX3	IPX3	IPX3	IPX3



			XP55	XP55R	XP55 600 R.P.M.	BT60	XP60	BT70	XP70	XP70 600 R.P.M.	XP 20" ORBITALE
Cleaning width		mm	530	550	530	600	600	685	685	685	508
Squeegee width		mm	816	816	816	816	816	842	842	842	816
Cleaning capacity per hour		m ² /h	2915	3025	2778	3316	3316	3767	3767	3767	2794
Number of brushes		n°	1	2	1	2	2	2	2	2	1
Brush diameter		mm	530	100	530	310	310	345	345	345	/
Maximum brush pressure		Kg	15,7	69,2	13	29,6	36,9	20,7	26,1	20,5	25,1
Brush rotation speed		g/1°	150	1360	570	200	200	200	200	570	/
Brush motor power		W	400	850x2	450	400x2	400x2	400x2	400x2	450x2	450
Drive motor power		W	200	200	200	200	200	200	200	200	200
Suction motor power		W	480	480	480	480	480	480	480	480	480
Overall power of machine in average operating conditions (P _M)		W	1008	1488	1104	1008	1008	1008	1008	1464	768
Maximum speed		Km/h	5,5	5,5	5,5	5,5	5,5	5,5	5,5	5,5	5,5
Solution tank		L	49	49	49	49	49	49	49	49	49
Dirty water tank		L	51	51	51	51	51	51	51	51	51
Front wheel diameter		mm	200	200	200	200	200	200	200	200	200
Rear wheel diameter		mm	80	80	80	80	80	80	80	80	80
Maximum slope		%	2	2	2	2	2	2	2	2	2
Gross weight (GVW)		Kg	234	252	236	243	240	243	240	243	250
Weight of the machine in transit without batteries		Kg	89	107	91	97	95	97	95	98	105
Weight of the machine in transit with batteries		Kg	177	195	179	185	183	185	183	186	193
Number of batteries		n°	2	2	2	2	2	2	2	2	2
Machine voltage V _M		V	12x2	12x2	12x2	12x2	12x2	12x2	12x2	12x2	12x2
Individual battery capacity		Ah (5h)	105	105	105	105	105	105	105	105	105
Supply voltage (battery recharge)	Version without on board battery charger	V	24 dc	24 dc	24 dc	24 dc	24 dc	24 dc	24 dc	24 dc	24 dc
Max current (battery recharge)		A	15	15	15	15	15	15	15	15	15
Mains supply voltage	Mains powered versions with on board charger	V	100-240V ac 50-60Hz	100-240V ac 50-60Hz	100-240V ac 50-60Hz	100-240V ac 50-60Hz	100-240V ac 50-60Hz	100-240V ac 50-60Hz	100-240V ac 50-60Hz	100-240V ac 50-60Hz	100-240V ac 50-60Hz
Max current (amperes), I		A	4,1	4,1	4,1	4,1	4,1	4,1	4,1	4,1	4,1
Machine dimensions		mm	X=1327 Y=1033 Z=563	X=1288 Y=1033 Z=640	X=1327 Y=1033 Z=563	X=1279 Y=1033 Z=653	X=1279 Y=1033 Z=653	X=1297 Y=1033 Z=735	X=1297 Y=1033 Z=735	X=1327 Y=1033 Z=735	X=1327 Y=1033 Z=563
Battery compartment dimensions (length, width, height)		mm	360 x 344 x 300								
Packed size (length, width, height)		mm	1365 x 695 x 1146	1335 x 780 x 1146	1365 x 695 x 1146	1335 x 780 x 1146	1335 x 780 x 1146	1335 x 780 x 1146	1335 x 780 x 1146	1335 x 780 x 1146	1365 x 695 x 1146
Sound pressure - Annex DD (Emission of acoustical noise) EN 60335-2-72: 2012		LpA (dBA)	58	59	58	59	59	59	59	59	58
Measurement uncertainty		K (dBA)	3	3	3	3	3	3	3	3	3
Vibration level (hand) - IEC 60335-2-72		ahv m/sec ²	≤ 2,5	≤ 2,5	≤ 2,5	≤ 2,5	≤ 2,5	≤ 2,5	≤ 2,5	≤ 2,5	≤ 2,5
Measurement uncertainty, k		m/sec ²	/	/	/	/	/	/	/	/	/
Vibration level (body) - IEC 60335-2-72		HBV m/sec ²	/	/	/	/	/	/	/	/	/
Measurement uncertainty, k		m/sec ²	/	/	/	/	/	/	/	/	/
Maximum water and detergent temperature		°C	55	55	55	55	55	55	55	55	55
Protection Grade		IP	IPX3	IPX3	IPX3	IPX3	IPX3	IPX3	IPX3	IPX3	IPX3

Gross weight (GVW): maximum permissible weight with the machine fully loaded and ready for use. The gross weight of the vehicle includes, where applicable, detergent solution tank full of clean water, empty dirty water tank (half full in the case of recycling systems), empty dust bags, the hopper filled to its rated capacity, the largest recommended batteries and all accessories such as cables, hoses, detergent, mops and brushes.

Transported weight: the weight of the machine including batteries, but excluding optionals (for example, the operators cabin, FOPS (Falling Object Protective Structure), second and third side brushes and front brush attachment), fresh water (in the case of scrubbers or combination machines) and the weight of a standard operator (75 kg).

Data subject to changes without prior warning

V, I: charging / supply values

V_M, P_M: machine in operation (all functions on)



TECHNICAL CHARACTERISTICS CT71

			C50 115V	C55 115V	C50 230V	C55 230V	B50	B55	BT50	BT55	XP50
Cleaning width		mm	496	530	496	530	496	530	496	530	496
Squeegee width		mm	816	816	816	816	816	816	816	816	816
Cleaning capacity per hour		m ² /h	1730	1850	1730	1850	1730	1850	2723	2915	2723
Number of brushes		n°	1	1	1	1	1	1	1	1	1
Brush diameter		mm	496	530	496	530	496	530	496	530	496
Maximum brush pressure		Kg	15,1	14,1	15,1	14,1	11,9	11,2	11,9	11,2	16,8
Brush rotation speed		g/1°	173	173	141/168	141/168	150	150	150	150	150
Brush motor power		W	570	570	570	570	400	400	400	400	400
Drive motor power		W	/	/	/	/	/	/	200	200	200
Suction motor power		W	430	450	430	450	480	480	480	480	480
Overall power of machine in average operating conditions (P _M)		W	690	736	690	736	720	768	960	1008	960
Maximum speed		Km/h	3,5	3,5	3,5	3,5	3,5	3,5	5,5	5,5	5,5
Solution tank		L	69	69	69	69	69	69	69	69	69
Dirty water tank		L	71	71	71	71	71	71	71	71	71
Front wheel diameter		mm	200	200	200	200	200	200	200	200	200
Rear wheel diameter		mm	80	80	80	80	80	80	80	80	80
Maximum slope		%	2	2	2	2	2	2	2	2	2
Gross weight (GVW)		Kg	178	178	178	178	247	248	255	255	255
Weight of the machine in transit without batteries		Kg	103	103	103	103	82	82	90	90	90
Weight of the machine in transit with batteries		Kg	/	/	/	/	169	169	177	177	177
Number of batteries		n°	/	/	/	/	2	2	2	2	2
Machine voltage V _M		V	/	/	/	/	12x2	12x2	12x2	12x2	12x2
Individual battery capacity		Ah (5h)	/	/	/	/	105	105	105	105	105
Supply voltage (battery recharge)	Version without on board battery charger	V	/	/	/	/	24 dc	24 dc	24 dc	24 dc	24 dc
Max current (battery recharge)		A	/	/	/	/	15	15	15	15	15
Mains supply voltage	Mains powered versions with on board charger	V	115V ac 60Hz	115V ac 60Hz	220-240V ac 50-60Hz	220-240V ac 50-60Hz	100-240V ac 50-60Hz	100-240V ac 50-60Hz	100-240V ac 50-60Hz	100-240V ac 50-60Hz	100-240V ac 50-60Hz
Max current (amperes), I		A	9,8	9,8	4,6	4,6	4,1	4,1	4,1	4,1	4,1
Machine dimensions		mm	X=1327 Y=1033 Z=563								
Battery compartment dimensions (length, width, height)		mm	/	/	/	/	360 x 344 x 300				
Packed size (length, width, height)		mm	1365 x 695 x 1146								
Sound pressure - Annex DD (Emission of acoustical noise) EN 60335-2-72: 2012		LpA (dBA)	59	59	58	58	58	58	58	58	58
Measurement uncertainty		K (dBA)	3	3	3	3	3	3	3	3	3
Vibration level (hand) - IEC 60335-2-72		ahv m/sec ²	≤ 2,5	≤ 2,5	≤ 2,5	≤ 2,5	≤ 2,5	≤ 2,5	≤ 2,5	≤ 2,5	≤ 2,5
Measurement uncertainty, k		m/sec ²	/	/	/	/	/	/	/	/	/
Vibration level (body) - IEC 60335-2-72		HBV m/sec ²	/	/	/	/	/	/	/	/	/
Measurement uncertainty, k		m/sec ²	/	/	/	/	/	/	/	/	/
Maximum water and detergent temperature		°C	55	55	55	55	55	55	55	55	55
Protection Grade		IP	IPX3	IPX3	IPX3	IPX3	IPX3	IPX3	IPX3	IPX3	IPX3



			XP55	XP55R	XP55 600 R.P.M.	BT60	XP60	BT70	XP70	XP70 600 R.P.M.	XP 20" ORBITALE
Cleaning width		mm	530	550	530	600	600	685	685	685	508
Squeegee width		mm	816	816	816	816	816	842	842	842	816
Cleaning capacity per hour		m ² /h	2915	3025	2778	3316	3316	3767	3767	3767	2794
Number of brushes		n°	1	2	1	2	2	2	2	2	1
Brush diameter		mm	530	100	530	310	310	345	345	345	/
Maximum brush pressure		Kg	15,7	69,2	13	29,6	36,9	20,7	26,1	20,5	25,1
Brush rotation speed		g/1°	150	1360	570	200	200	200	200	570	/
Brush motor power		W	400	850x2	450	400x2	400x2	400x2	400x2	450x2	450
Drive motor power		W	200	200	200	200	200	200	200	200	200
Suction motor power		W	480	480	480	480	480	480	480	480	480
Overall power of machine in average operating conditions (P _M)		W	1008	1488	1104	1008	1008	1008	1008	1464	768
Maximum speed		Km/h	5,5	5,5	5,5	5,5	5,5	5,5	5,5	5,5	5,5
Solution tank		L	69	69	69	69	69	69	69	69	69
Dirty water tank		L	71	71	71	71	71	71	71	71	71
Front wheel diameter		mm	200	200	200	200	200	200	200	200	200
Rear wheel diameter		mm	80	80	80	80	80	80	80	80	80
Maximum slope		%	2	2	2	2	2	2	2	2	2
Gross weight (GVW)		Kg	255	273	257	263	261	263	261	264	271
Weight of the machine in transit without batteries		Kg	90	108	91	98	95	98	95	98	105
Weight of the machine in transit with batteries		Kg	177	195	179	185	183	185	183	186	193
Number of batteries		n°	2	2	2	2	2	2	2	2	2
Machine voltage V _M		V	12x2	12x2	12x2	12x2	12x2	12x2	12x2	12x2	12x2
Individual battery capacity		Ah (5h)	105	105	105	105	105	105	105	105	105
Supply voltage (battery recharge)	Versioni senza carica batterie a bordo	V	24 dc	24 dc	24 dc	24 dc	24 dc	24 dc	24 dc	24 dc	24 dc
Max current (battery recharge)		A	15	15	15	15	15	15	15	15	15
Mains supply voltage	Versioni cavo e con carica batterie a bordo	V	100-240V ac 50-60Hz	100-240V ac 50-60Hz	100-240V ac 50-60Hz	100-240V ac 50-60Hz	100-240V ac 50-60Hz	100-240V ac 50-60Hz	100-240V ac 50-60Hz	100-240V ac 50-60Hz	100-240V ac 50-60Hz
Max current (amperes), I		A	4,1	4,1	4,1	4,1	4,1	4,1	4,1	4,1	4,1
Machine dimensions		mm	X=1327 Y=1033 Z=563	X=1288 Y=1033 Z=640	X=1327 Y=1033 Z=563	X=1279 Y=1033 Z=653	X=1279 Y=1033 Z=653	X=1297 Y=1033 Z=735	X=1297 Y=1033 Z=735	X=1327 Y=1033 Z=735	X=1327 Y=1033 Z=563
Battery compartment dimensions (length, width, height)		mm	360 x 344 x 300								
Packed size (length, width, height)		mm	1365 x 695 x 1146	1335 x 780 x 1146	1365 x 695 x 1146	1335 x 780 x 1146	1335 x 780 x 1146	1335 x 780 x 1146	1335 x 780 x 1146	1335 x 780 x 1146	1365 x 695 x 1146
Sound pressure - Annex DD (Emission of acoustical noise) EN 60335-2-72: 2012		LpA (dBA)	58	59	58	59	59	59	59	59	58
Measurement uncertainty		K (dBA)	3	3	3	3	3	3	3	3	3
Vibration level (hand) - IEC 60335-2-72		ahv m/sec ²	≤ 2,5	≤ 2,5	≤ 2,5	≤ 2,5	≤ 2,5	≤ 2,5	≤ 2,5	≤ 2,5	≤ 2,5
Measurement uncertainty, k		m/sec ²	/	/	/	/	/	/	/	/	/
Vibration level (body) - IEC 60335-2-72		HBV m/sec ²	/	/	/	/	/	/	/	/	/
Measurement uncertainty, k		m/sec ²	/	/	/	/	/	/	/	/	/
Maximum water and detergent temperature		°C	55	55	55	55	55	55	55	55	55
Protection Grade		IP	IPX3	IPX3	IPX3	IPX3	IPX3	IPX3	IPX3	IPX3	IPX3

Gross weight (GVW): maximum permissible weight with the machine fully loaded and ready for use. The gross weight of the vehicle includes, when applicable, detergent solution tank full of clean water, empty dirty water tank (half full in the case of recycling systems), empty dust bags, the hopper filled to its rated capacity, the largest recommended batteries and all accessories such as cables, hoses, detergent, mops and brushes.

Transported weight: the weight of the machine including batteries, but excluding optionals (for example, the operator's cabin, FOPS (Falling Object Protective Structure), second and third side brushes and front brush attachment), fresh water (in the case of scrubbers or combination machines) and the weight of a standard operator (75 kg).

Data subject to changes without prior warning

V, I: charging / supply values

V_M, P_M: machine in operation (all functions on)





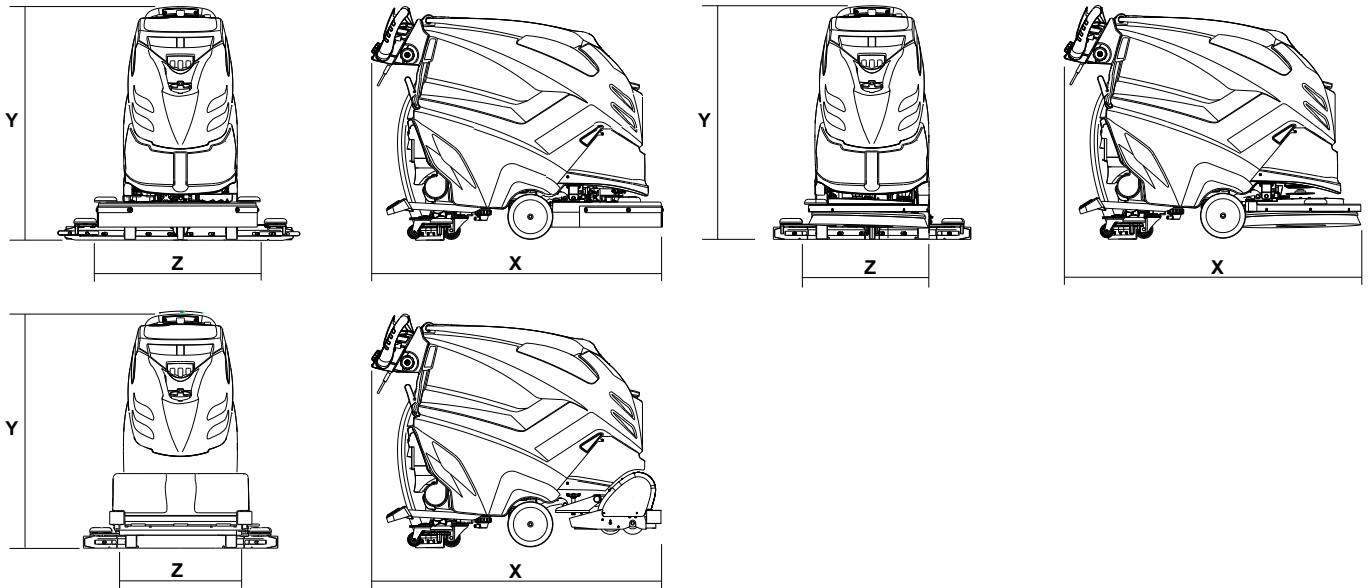







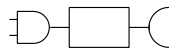

MACHINE DIMENSIONS

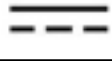

X-Y-Z: See "TECHNICAL SPECIFICATIONS" table

SAFETY SYMBOLS

	WARNING! RISK OF CUTTING		EARTHING POINT.
	WARNING! RISK OF CRUSHING LIMBS		EXTERNAL BATTERY CHARGER CONNECTION POINT.
	WARNING! RISK OF ABRASION		DO NOT WASH THE MACHINE BY SPRAYING DIRECTLY WITH WATER OR USING HIGH PRESSURE WATER JETS.
	WARNING! RISK OF ENTANGLEMENT		
	WARNING! RISK OF ACID BURNS		
	WARNING! RISK OF BURNS		
	MAXIMUM SLOPE		
	OPERATOR'S MANUAL, OPERATING INSTRUCTIONS		
	READ THE OPERATOR'S MANUAL		
	DIRECT CURRENT SYMBOL		
	INSULATION CLASS, THIS CLASSIFICATION ONLY APPLIES TO MACHINES POWERED BY BATTERIES.		

GENERAL INFORMATION

Purpose of this manual

This manual has been written by the Manufacturer and is an integral part of the machine¹.

It defines the purpose for which the machine has been designed and constructed and contains all the information required by operators².

In addition to this manual, which contains information for operators, other publications are available providing specific information for maintenance personnel³.

The terms "right" and "left", "clockwise" and "anti-clockwise" refer to the forward movement of the machine.

Constant compliance with the instructions provided in this manual guarantees the safety of the operator and the machine, ensures low running costs and high quality results and extends the working life of the machine. Failure to follow these instructions may lead to injury to the operator or damage to the machine, floor and environment.

To find the topic that interests you more rapidly, consult the list of contents at the beginning of the manual.

Parts of the text requiring special attention are printed in bold and preceded by the symbols illustrated and described here.

! DANGER

Indicates the need for attention in order to avoid a series of consequences which could cause death or serious injury to personnel.

! WARNING

Indicates the need for attention in order to avoid a series of consequences which could cause damage to the machine or work environment or financial loss.

! INFORMATION

Very important instructions

In line with the company's policy of constant product development and updating, the Manufacturer reserves the right to make modifications without prior notice.

Although your machine may differ appreciably from the illustrations in this document, the correctness and validity of the instructions contained in this manual are guaranteed.

Identifying the machine

The nameplate provides the following information:

- ▶ Name of manufacturer.
- ▶ Model
- ▶ Serial number.
- ▶ Year of manufacture.
- ▶ Power supply voltage (charging/supply value).
- ▶ Current intensity (charging value).
- ▶ Gross weight.
- ▶ IP degree of protection.
- ▶ Machine voltage (in average operating conditions)
- ▶ Machine power (in average operating conditions)
- ▶ Maximum negotiable gradient.

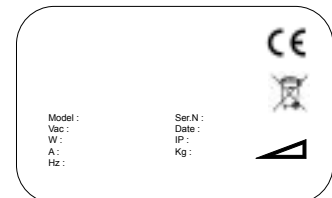

Documentation provided with the machine

- ▶ Operator's manual;
- ▶ Certificate of warranty;
- ▶ CE certificate of conformity.

1 The definition "machine" replaces the trade name covered by this manual.

2 Persons responsible for using the machine without performing any operations requiring precise technical skills.

3 Persons with experience, technical training and a knowledge of legislation and standards, able to perform all the necessary operations and to recognise and avoid possible risks in handling, installation, use and maintenance of this machine.

TECHNICAL INFORMATION

General description

This machine is a scrubber drier for washing and drying flat, horizontal, smooth or moderately rough, even and obstacle free floors in civil and industrial premises.

The scrubber drier spreads a solution of water and detergent in the correct concentration on the floor and then scrubs it to remove the dirt. By carefully choosing the detergent and brushes (or abrasive disks) from the wide range of accessories available, the machine can be adapted to a wide range of combinations of types of floor and dirt.

A suction system incorporated in the machine dries the floor after washing by means of the low pressure generated in the dirty water tank by the suction motor. The squeegee connected to the tank collects the dirty water.

Key

The main parts of the machine are as follows:

- ▶ The tank (fig. 1-ref. 1), contains and carries the mixture of clean water and cleaning product and collects the dirty water picked up from the floor after washing.
- ▶ Control panel (fig. 1-ref. 2).
- ▶ Head assembly (fig. 1-ref. 3): the main element comprises the brushes/rollers which distribute the detergent solution onto the floor and remove the dirt.
- ▶ Squeegee assembly (fig. 1-ref. 4): wipes and dries the floor by collecting the water.

Hazard areas

- ▶ Control panel: risk of injury from short circuits.
- ▶ Tank assembly: when using certain detergents, danger of irritation for eyes, skin, mucous membranes and respiratory tract and of asphyxia. Danger represented by the dirt collected from the environment (germs and chemical substances). Danger of crushing between the two tanks when the dirty water tank is replaced on top of the detergent tank.
- ▶ Washing head assembly: danger due to brush rotation.
- ▶ Front/rear wheels: risk of crushing between the wheels and chassis.
- ▶ Motor/battery compartment: danger of short circuit between the battery poles and presence of hydrogen during charging.

Accessories

- ▶ Soft, hard and abrasive brushes.
- ▶ Chem-Dose tank.
- ▶ S.P.E. battery charger CBHD3.

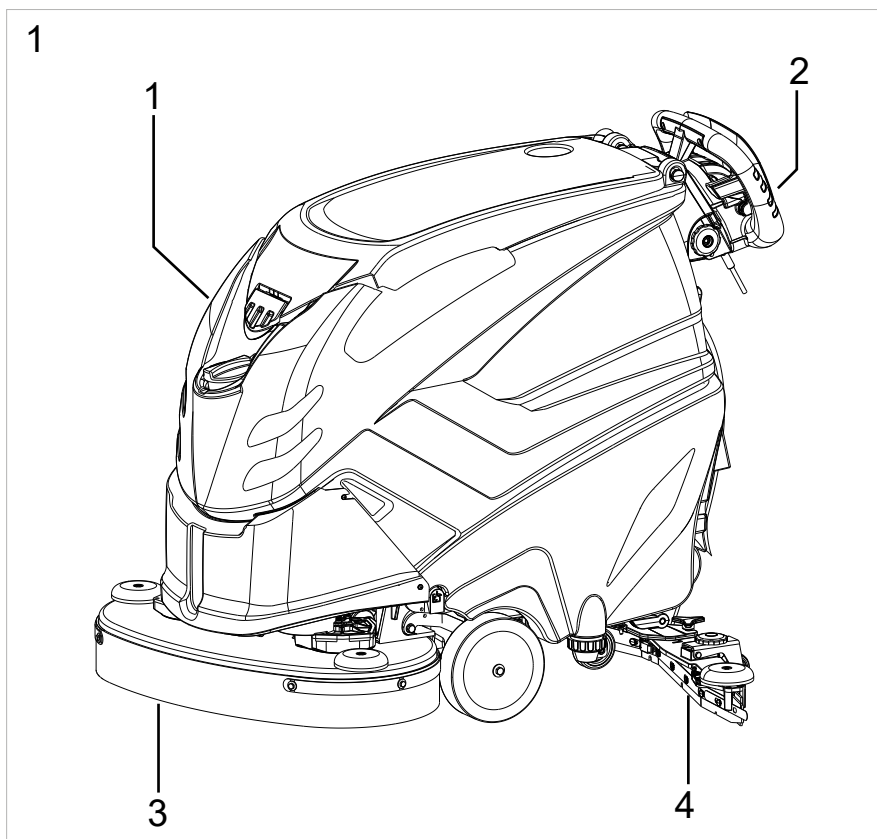

MOVEMENT AND INSTALLATION

Lifting and transporting the packaged machine

! WARNING

During all lifting operations, make sure the packaged machine is firmly secured to avoid it tipping up or being accidentally dropped.
Always load/unload lorries in adequately illuminated areas.

The machine is packaged on a wooden pallet by the Manufacturer. It must be loaded onto the transporting vehicle using suitable equipment (see EC Directive 2006/42 and subsequent amendments and/or additions). At destination, it must be unloaded using similar means.

A fork lift truck must always be used to lift the packaged body of the machine. Handle with care to avoid knocking or overturning the machine.

Delivery checks

When the carrier delivers the machine, make sure the packaging and machine are both whole and undamaged. If the machine is damaged, make sure the carrier is aware of the damage and before accepting the goods, reserve the right (in writing) to request compensation for the damage.

Unpacking:

! WARNING

When unpacking the machine, the operator must be provided with the necessary personal protection devices (gloves, goggles, etc.) to limit the risk of accident.

Proceed as follows to unpack the machine:

- ▶ Cut and remove the plastic straps using scissors or nippers.
- ▶ Remove the cardboard packaging.
- ▶ Remove the bags from the battery compartment and check their contents:
 - this Operator's Manual, the maintenance manual, declaration of conformity, certificate of warranty;
 - battery bridges with terminals;
 - 1 connector for battery charger.
 - 2 electronic keys.
- ▶ Remove the metal brackets that secure the front wheels and the machine's chassis to the pallet. **To remove the metal bracket that fixes the frame to the pallet, undo the screw, lift and rotate the tank backwards, then proceed with dismantling.**
- ▶ Using a sloping ramp, push the machine backwards off the pallet. The machine must not be raised.
- ▶ Unpack the brushes from their packaging.
- ▶ Clean the outside of the machine, taking care to respect safety regulations.

Once the machine is clear of the packaging, proceed to install the batteries (see the "**Batteries: installation and connection**" section).

The packaging may be kept as it can be reused to protect the machine if it is moved to another site or to a repair workshop.

Otherwise it must be disposed of in compliance with current legislation.

Batteries (Battery version)

Two different types of battery may be installed on these machines:

- ▶ Leak-proof tubular batteries (WET): these require regular checks on electrolyte level. When necessary, top up with distilled water until the plates are covered. Do not over-fill (5 mm max. above the plates).
- ▶ Gel or AGM batteries: this type of battery requires no maintenance.

Battery technical characteristics must correspond to those listed in the **Technical characteristics** section. The use of higher capacity batteries could seriously jeopardise manoeuvrability and lead to the drive motor overheating. Batteries with a lower capacity and weight will require charging more frequently.

Batteries must be kept charged, dry and clean and the connections must be kept tight.

The battery is a sealed unit and guaranteed safe under normal circumstances; in the unlikely event of fluid leaking from the battery, do not touch the fluid and be sure to take the following precautions:

- ▶ Contact with the skin can cause irritation; wash with soap and water.
- ▶ Inhalation of vapours can cause irritation to the airways; stay out in the open air and consult a doctor.
- ▶ Contact with the eyes can cause irritation; flood the eyes with water immediately and thoroughly for at least 15 minutes, and consult a doctor.

! WARNING

Do not use NON-rechargeable batteries

! INFORMATION

**Follow the instructions below to configure the machine's software for the type of batteries installed:
see the "Technical menu section"**

Batteries: preparation

! INFORMATION

Installation and connection / removal of the batteries must be carried out by an IPC-approved technician (referred to hereinafter as skilled technician).

! DANGER

During installation of the batteries or any type of battery maintenance, the skilled technician must be provided with the necessary personal protection devices (gloves, goggles, overalls, etc) to limit the risk of accidents. Keep away from naked flames, do not short circuit the battery poles, do not generate sparks and do not smoke.

Batteries (WET) are normally supplied filled with acid and ready for use.

If the batteries are dry, proceed as follows before installing them in the machine:

Remove the caps and fill all elements with sulphuric acid solution specific for batteries until the plates are entirely covered (this requires at least a couple of refills for each element). IF IN DOUBT, CONTACT THE DEALER.

Leave the batteries stand for 4-5 hours to allow air bubbles to come to the surface and the plates to absorb the electrolyte.

Make sure the level of electrolyte is still above the plates and if necessary top up with sulphuric acid solution.

Close the caps.

Install the batteries in the machine (following the procedure described below).

Charge the batteries before starting up the machine for the first time. Follow the instructions in the "Battery maintenance and charging" section.

Batteries: installation and connection

! DANGER

Remove the electronic key from the instrument panel before installing and connecting the batteries.

Make sure you connect the terminals marked with a "+" to the positive poles of the battery. Do not check the battery charge by sparking.

Meticulously follow the instructions given below as short circuiting the batteries could cause them to explode.

! DANGER

Before releasing the screw ring on the tank opening cable, which is only permitted for battery installation/replacement and for checking/restoring the level of sulphuric acid solution, make sure that the machine is standing on a perfectly horizontal surface.

After completing the above operations, hook the screw ring into the loop indicated by the black arrow (see figure below) and secure the screw of the carabiner with a hexagonal spanner so that it cannot be opened manually afterwards.

Rotate the tank backwards, then place the batteries in the compartment in the direction shown in the drawing on the tank.

Connect the wiring terminals to the battery poles, tighten the terminals to the poles and coat with vaseline.

Lower the tank into the working position.

When using the machine, follow the instructions below.

! WARNING

Never allow the batteries to become excessively flat as this could damage them irreparably.

Batteries: removal

! DANGER

Before releasing the screw ring on the tank opening cable, which is only permitted for battery installation/replacement and for checking/restoring the level of sulphuric acid solution, make sure that the machine is standing on a perfectly horizontal surface.

After completing the above operations, hook the screw ring into the loop indicated by the black arrow (see figure below) and secure the screw of the carabiner with a hexagonal spanner so that it cannot be opened manually afterwards.

WARNING!

When removing the batteries, ensure that the battery charger is unplugged from the power socket

! DANGER

When removing the batteries, the skilled technician must be equipped with suitable personal protection devices (gloves, goggles, overalls, safety shoes, etc) to reduce the risk of accidents. Make sure the switches on the control panel are in the «0» position (off) and the machine is turned off. Keep away from naked flames, do not short circuit the battery poles, do not cause sparks and do not smoke. Proceed as follows:

- ▶ Disconnect the battery cables and bridge terminals from the battery poles.
- ▶ If necessary, remove the devices fixing the battery to the base of the machine.
- ▶ Lift the batteries from the compartment using suitable lifting equipment.

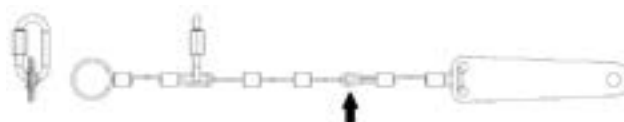

Choosing a battery charger

Make sure the battery charger is compatible with the batteries to be charged.

Tubular lead batteries (WET): it is recommended to use an electronic battery charger; always refer to the manufacturer and the battery charger manual to confirm that the external battery charger is suitable.

Gel or AGM batteries: use a charger specific for this type of battery.

! DANGER

Use CE-marked battery chargers that comply with the relevant product standards (EN60335-2-29), featuring double or reinforced insulation between input and output, and a SELV output circuit with a maximum output of 24 V and maximum charge current of 15 A

Preparing the battery charger

If you wish to use a battery charger not provided with the machine, you must fit it with the connector supplied with the machine.

The connector supplied for the external battery charger is suitable for cables with a maximum cross-section of 16 mm².

To install the connector, proceed as follows:

remove about 13 mm of protective sheath from the red and black wires of the battery charger;

insert the wires into the connector contacts and squeeze them forcefully with suitable pliers;

respect the polarity (red wire + black wire -) when inserting the wires into the connector.

Squeegee installation and adjustment

Lower the squeegee using the lever (fig. 3-ref. 1).

Lift the squeegee fastening levers (fig. 3-ref. 3), insert the squeegee in the slots in the support (fig. 3-ref. 2), then lower the fastening levers (fig. 3-ref. 3) and insert the suction hose (fig. 3-ref. 4) in the squeegee.

Squeegee adjustment

The squeegee blades scrape the film of water and detergent from the floor and prepare the way for perfect drying. With time, the constant rubbing makes the edge of the blade in contact with the floor rounded and cracked, reducing the drying efficiency and requiring it to be replaced. The state of wear should be checked frequently.

For perfect drying, the squeegee must be adjusted in such a way that the edge of the rear blade bends during operation by about 45° with respect to the floor at every point. The angle of the blades can be adjusted using the screw (fig. 3-ref. 5), while the height of the squeegee from the floor can be adjusted using the knobs (fig. 4-ref. 6).

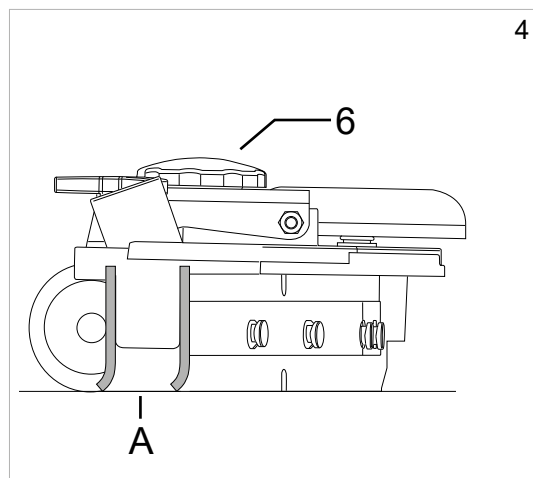
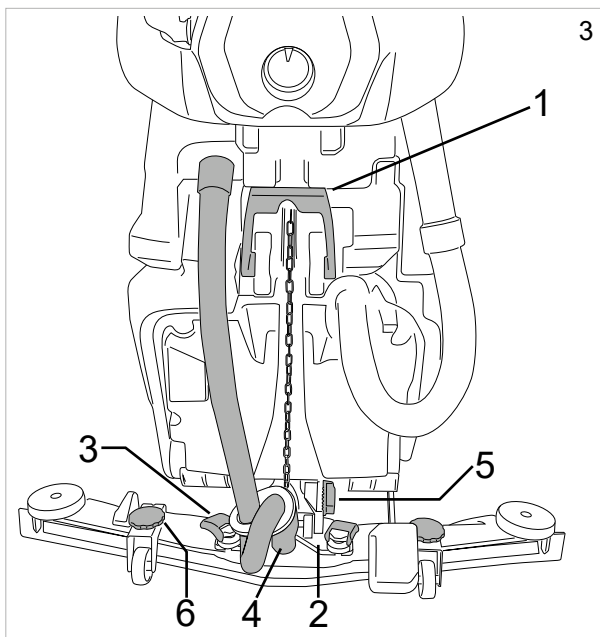

Brush installation

Automatic brush attachment, version "B"- "C" (Fig.21):

raise the machine head by pushing the head lift pedal down and to the left, then using the operation selector, select the Brush control, rest the brush on the floor in front of the machine and centre it with the head. Lower the head by pushing the head lift pedal down and to the right and activate the drive lever momentarily; the brush will be attached automatically to the hub on the flange. If the operation is not successful, repeat by pressing the lever again and repeating the centring. Use of abrasive/microfibre disks: fit the abrasive/microfibre disk on the drive disk and perform the operations described for fitting the brush on the scrubber drier.

Automatic brush attachment, version "BT" (Fig.21):

raise the machine head by pushing the head lift pedal down and to the left, then using the operation selector, select the Brush control, rest the brush on the floor in front of the machine and centre it with the head. Lower the head by pushing the head lift pedal down and to the right, turn the selector to the "OFF" position, press the "SET" button once then press the "+" button, the machine will complete the attachment sequence. Use of abrasive/microfibre disks: fit the abrasive/microfibre disk on the drive disk and perform the operations described for fitting the brush on the scrubber drier.

Automatic brush attachment, version "XP":

position the brush underneath the head, turn the selector to the "OFF" position, press the "SET" button once then press the "+" button, the machine will complete the brush attachment sequence.

Automatic brush release, version "B-BT" (Fig.21): raise the machine head by pushing the head lift pedal down and to the left, turn the selector to the "OFF" position, press the "SET" button once then press the "-" button, the machine will complete the release sequence.

Automatic brush release, version "XP":

turn the selector to the "OFF" position, press the "SET" button once then press the "-" button, the machine will complete the release sequence.

Brush release, version "C"

raise the machine head by pushing the head lift pedal down and to the left, then using the operation selector, select the Brush control and engage the drive lever for 4 seconds; on releasing the lever, the machine will release the brush automatically.

Attaching the brush roller (Fig. 23):

raise the machine head by pushing the head lift pedal down and then to the left, fit the rollers in their housing by first inserting them on the drive pulley, then pushing them upwards until they click into place.

Releasing the brush roller (Fig. 23):

raise the machine head by pushing the head lift pedal down and then to the left, release the rollers by pulling them downwards from the side opposite the drive pulley, then extracting them from their housing.

! INFORMATION

Follow the instructions given below to configure the machine's control software to use the display language you require:

See the "Technical menu" section.

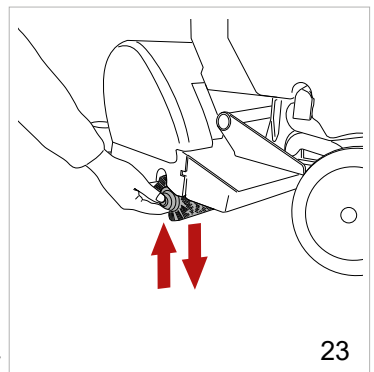
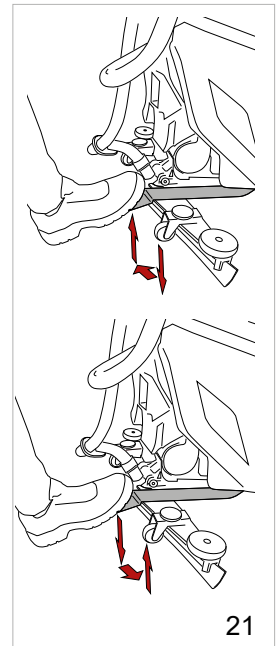

Lifting and transporting the machine

! WARNING

All phases of lifting and moving must be performed in an adequately illuminated environment with the adoption of the safety measures most appropriate to the situation.

The operator must always use personal protection devices.

Proceed as follows to load the machine onto a means of transport:

- ▶ Empty the tanks.
- ▶ Remove the batteries.
- ▶ Push the machine onto the pallet using a sloping ramp, securing the front wheels and the chassis using the brackets supplied. The machine must not be raised.
- ▶ Lift the pallet (with the machine) using a fork lift truck and load it onto the means of transport.
- ▶ Anchor the machine to the means of transport with cables connected to the pallet and to the machine itself.

Quick head change (BATTERY POWERED VERSIONS ONLY)

The scrubber head can be changed as described below.

Removing the head:

- ▶ Lower the head (mechanical version) or select "CHANGE HEAD" (electronic version) in the "Technical menu", pressing the "+" or "-" button raises or lowers the head, releasing the button stops the actuator. Pressing the "SET" button exits the page and the machine lifts the head.
- ▶ Electrically disconnect the head from the machine's wiring, disconnecting the connector highlighted in the drawing (fig. 5-ref. 1) and disconnecting the motor connector/connectors.
- ▶ Open the hook (fig. 5, ref. 2).
- ▶ Unscrew the two knobs (fig. 5-ref. 3).
- ▶ Remove the head.

Installing the head:

- ▶ Perform the procedure described previously but in the reverse order.

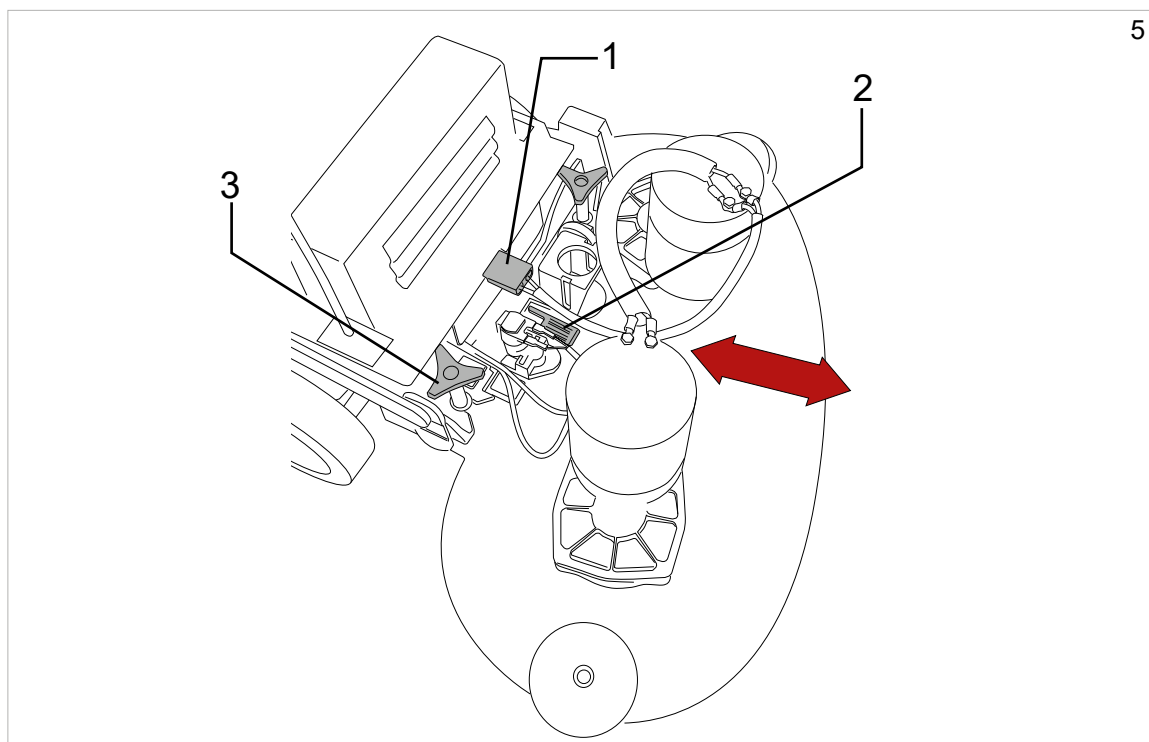

PRACTICAL GUIDE FOR THE OPERATOR

! WARNING

Before starting work, wear overalls, ear protectors, non-slip and waterproof shoes, mask to protect the respiratory tract, gloves and all other personal protection devices necessitated by the work environment.

! WARNING

Never leave the machine unattended or parked with the electronic ignition key inserted.

! INFORMATION

If you are using the machine for the first time, we recommend trying it out on a large obstacle-free surface first to acquire the necessary familiarity.

! WARNING

To avoid damaging the surface of the floor you are cleaning, avoid rotating the brushes with the machine stationary.

! WARNING

Always dilute the detergent according to the manufacturer's instructions. Do not use sodium hypochlorite (bleach) or other oxidants, particularly in strong concentrations. Do not use solvents or hydrocarbons. The water and detergent temperature must not exceed the maximum indicated in the "Technical specifications". They must be free of sand and/or other impurities.

The machine has been designed for use with low-foam biodegradable detergents made specifically for scrubber driers.

For a complete and up-to-date list of the detergents and chemicals available, contact the Manufacturer.

Use products suitable for the floor and dirt to be removed only.

Follow the safety regulations on use of detergents given in the section "Safety regulations".

Preparing the machine for work

Proceed as follows before starting work:

- ▶ Check that the display shows the batteries to be fully charged. Recharge if necessary. See the "**Battery maintenance and charging**" section.
- ▶ Make sure that the dirty water tank is empty. Empty it if necessary, see "**Emptying the dirty water tank**".
- ▶ Make sure that the solution tank is full. Fill it if necessary, see "**Filling the water/detergent tank**". If the machine is not fitted with the "Chem-Dose" accessory, add detergent to the tank in the required percentage, using the measuring cap.
- ▶ Adjust the instrument panel height by unscrewing the adjustment knobs (fig. 10-ref. 4).

Controls

- ▶ **Display (fig. 7):**
 - ▶ Displays the maximum speed ramp set (fig. 7-ref. 1), version with electric drive.
 - ▶ The percentage of battery charge (fig. 7-ref. 2).
 - ▶ The machine operating hours (fig. 7-ref. 4) standard version, the minutes remaining until the detergent runs out, and alternatively the sq.m remaining until the detergent runs out on the APC version (ADVANCED PRODUCTIVITY CONTROL).
 - ▶ The number of litres of detergent in the tank, on the **APC version (ADVANCED PRODUCTIVITY CONTROL)** (fig. 7-ref. 3).
 - ▶ The alarms (see chapter "Alarms on the display").
 - ▶ Indication of the set operating program (fig. 7-ref. 5).
 - ▶ Brush indication, with pressure level (fig. 7-ref. 6).
 - ▶ Water delivery indication, with level (fig. 7-ref. 7).
 - ▶ Suction indication, with speed level (fig. 7-ref. 8).

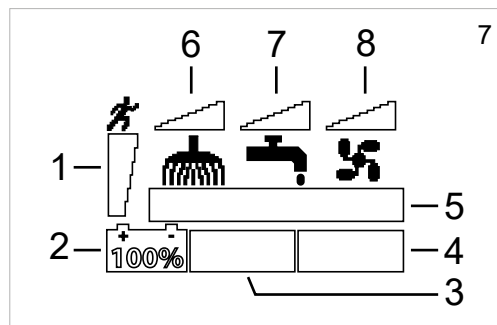

- ▶ **Electronic key (fig. 8-ref. 1):** inserting the key enables operation of the machine, remove the key to completely switch off the machine in an emergency.
- ▶ **Main Switch (mains powered versions only):** press the switch to power the machine (fig. 25, rif. 1);
- ▶ **Operation selector (fig. 8-ref. 2):** turn to select the machine operating program:
 - ▶ **OFF (Fig.9-Ref.3):** in this position the electric drive is enabled (where featured), the speed can be adjusted using the “-” and “+” buttons. Press the “SET” button to manage the following functions:
 - ▶ pressing the “SET” button once accesses the attach/release brush menu, pressing the “-” button enables brush release, pressing the “+” button enables brush attachment on machines fitted with actuator.
 - ▶ pressing the “SET” button twice accesses the **“Technical menu”**, to enter the menu press “-” and “+” together.
 - ▶ **Suction motor (fig. 9-ref. 4):** in this position the suction motor is activated and the electric drive is enabled (where featured), the speed can be adjusted using the “-” and “+” buttons . The suction motor starts by activating the drive lever, in the version with electric drive the suction motor starts by activating the drive lever after having lowered the squeegee lift lever (fig. 10-ref. 3). Press the “SET” button to manage the following function:
 - ▶ pressing the “SET” button once accesses the remote suction menu, pressing the “+” button starts the suction motor, pressing the “-” button stops the suction motor, is the suction motor can also be stopped by operating the drive lever.
 - ▶ **Brush (fig. 9-ref. 5):** in this position the suction motor is activated and the electric drive is enabled (where featured), the speed can be adjusted using the “-” and “+” buttons. Press the “SET” button to manage the following functions:
 - ▶ pressing the “SET” button once accesses the detergent delivery menu, delivery can be adjusted using the “+” and “-” buttons.
 - ▶ pressing the “SET” button twice accesses the scrubber head pressure menu, the pressure can be adjusted using the “+” and “-” buttons on models equipped with actuator.
 - ▶ pressing the “SET” button three times accesses the Chem Dose menu, detergent delivery can be adjusted using the “+” and “-” buttons, on models equipped with Chem Dose.
 - ▶ **Auto (fig. 9-ref. 6):** in this position all of the machine’s functions are activated, the head pressure value on models equipped with actuator and the detergent delivery value are pre-set by the manufacturer, these can be modified in the **“Technical menu”** (see chapter **“Technical menu”**), the electric drive is enabled (where featured), the speed can be adjusted using the “-” and “+” buttons. Press the “SET” button to manage the following functions:
 - ▶ pressing the “SET” button once accesses the detergent delivery menu, delivery can be adjusted using the “+” and “-” buttons.
 - ▶ pressing the “SET” button twice accesses the scrubber head pressure menu, the pressure can be adjusted using the “+” and “-” buttons on models equipped with actuator.
 - ▶ pressing the “SET” button three times accesses the Chem Dose menu, detergent delivery can be adjusted using the “+” and “-” buttons, on models equipped with Chem Dose.
 - ▶ **Eco (fig. 9-ref. 7):** in this position all of the machine’s functions are activated, the head pressure value on models equipped with actuator and the detergent delivery value are pre-set by the manufacturer, these parameters cannot be modified, the electric drive is enabled (where featured), the speed can be adjusted using the “-” and “+” buttons,

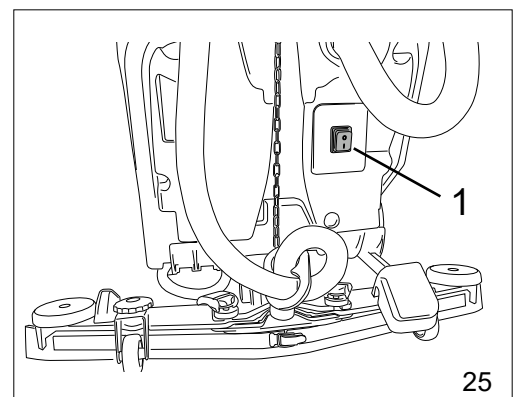
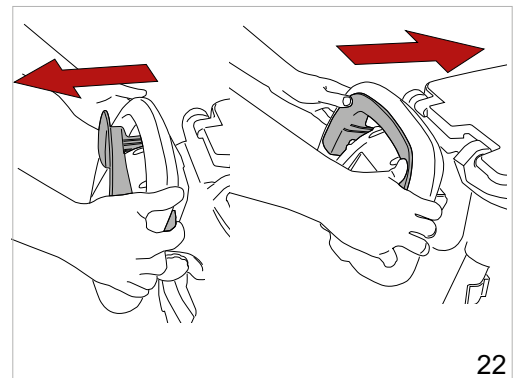
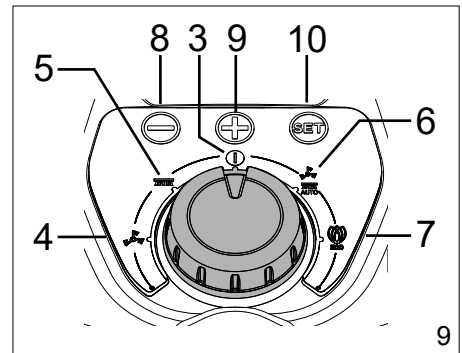
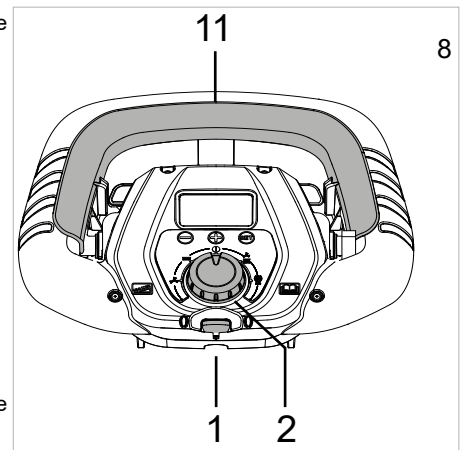

- ▶ **Drive lever (fig. 22):** pulling the lever towards the operator engages reverse gear, pushing the lever forwards engages forward gear, to change speed press the "+" and "-" buttons.
- ▶ **Tank release button (fig. 10-ref. 1):** releases the tank from the chassis so it can be rotated backwards.
- ▶ **Head lift pedal (fig. 10-ref. 2):** raises and lowers the head on models without actuator.
- ▶ **Squeegee lift lever (fig. 10-ref. 3):** raises and lowers the squeegee, enabling or disabling the suction motor on the version with electric drive.
- ▶ **Instrument panel height adjustment knobs (fig. 10-ref. 4):** unscrew the two knobs to adjust the height of the instrument panel.
- ▶ **"SET" button (fig. 9-ref. 10):** when pressed accesses the machine operating program submenus, in the **"Technical menu"** selects the parameter to be modified and confirms the value entered.
- ▶ **"+" button (fig. 9-ref. 9):** increases the value in the machine operating program submenus, in the **"Technical menu"** selects the next parameter or increases the value of the selected parameter.
- ▶ **Button "-" (fig. 9-ref. 8):** decreases the value in the machine operating program submenus, in the **"Technical menu"** selects the previous parameter or decreases the value of the selected parameter.

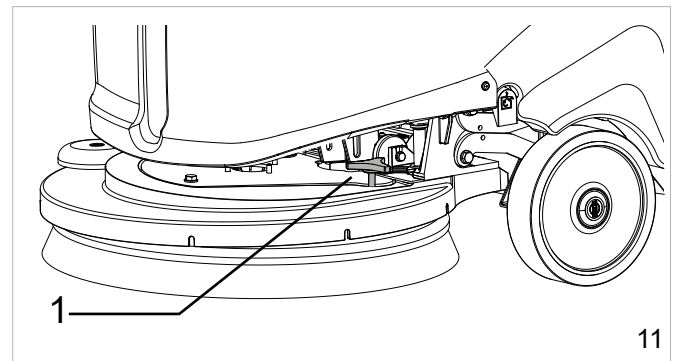
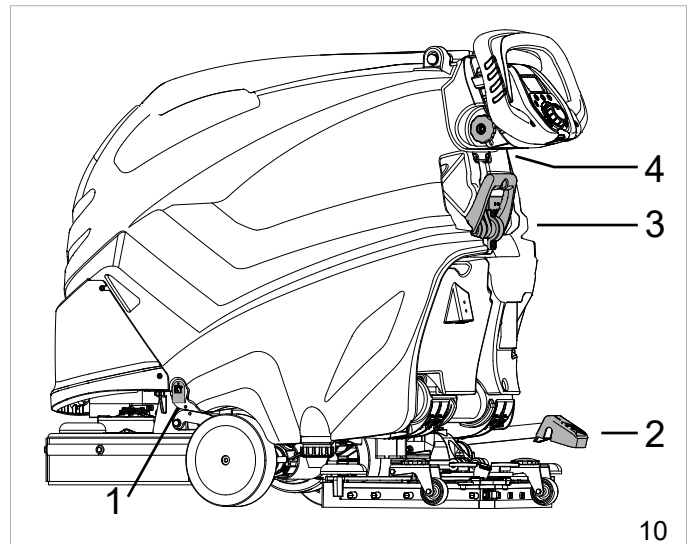

Working

- ▶ **Mains powered versions:** plug the machine into the mains power socket and press the main switch (fig. 25, ref. 1);
- ▶ Insert the electronic key.
- ▶ Using the operation selector, select the scrubbing program.
- ▶ Activate the drive lever, lower the squeegee and start working.
- ▶ In the machines without electric drive, turning the knob (fig. 11-ref. 1) corrects any tendency to deviate from a straight line.

Some useful tips to get the most from your scrubber drier

In the event of particularly stubborn dirt on the floor, washing and drying can be performed in two separate operations.

Prewashing with brushes or pads:

- ▶ Select the Brush operating program.
- ▶ Activate the drive lever, start working.
- ▶ If necessary, adjust the flow of detergent delivered to the brush; the outlet flow must be metered in relation to the required travel speed; the slower the machine travels, the less detergent must be delivered.
- ▶ Persist when washing particularly dirty points to give the detergent time to perform its chemical action detaching and suspending the dirt and the brushes time to exert an effective mechanical action.

Drying:

- ▶ Select the Suction operating program, lower the squeegee.
- ▶ Activate the drive lever, start working.
- ▶ Pass over the same area washed previously. The result is equivalent to in-depth washing and subsequent ordinary maintenance will take less time.

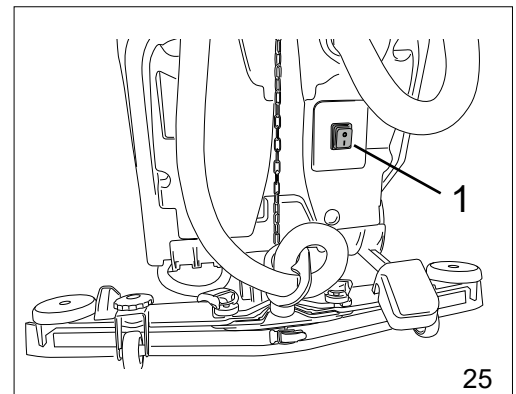

Emptying the collection tank

If the tank is full, the display shows the corresponding alarm, see the chapter “Display alarms”; after a few seconds, the suction motor shuts down, then stop the machine and empty the tank following the instructions shown below. To resume work, turn the operation selector to the OFF position (reset errors):

- ▶ Switch off all the machine's functions.
- ▶ Take the machine to the disposal area.
- ▶ Unhook the hose from the clip.
- ▶ Empty the tank using the hose (fig. 12, ref. 1), at the end rinse the tank with clean water.

Emptying the water/detergent tank

To empty the tank, follow the instructions shown below:

- ▶ Switch off all the machine's functions.
- ▶ Take the machine to the disposal area.
- ▶ Stop the machine.
- ▶ Empty the tank by unscrewing the filter assembly (fig. 13-ref. 1).

Emptying the roller head bin

- ▶ Remove the sweeper collection bin (Fig. 24), dispose of the contents and rinse out the bin with clean water.

Filling the water/detergent tank

Fill the tank through the opening provided (fig. 14, Ref. 1). The machine is equipped with a graduated measuring cap that can be used to dilute the detergent inside the tank. If the tank is empty, the display shows the corresponding alarm, see the chapter “Display alarms”; to resume work, turn the operation selector to the OFF position (reset errors).

Filling the Chem-Dose tank (accessory)

Open the dirty water tank lid, fill the container highlighted in the drawing (fig. 14-ref. 2) with detergent.

Finishing work

! INFORMATION

Empty the dirty water tank and recharge the batteries

After having finished work, remove the electronic key.

Moving the machine when not in operation

Proceed as follows to move the machine:

- ▶ Raise the squeegee.
- ▶ Raise the head.
- ▶ Move the operating program selector to Off.
 - ▶ Versions with mechanical drive: push or pull.
 - ▶ Version with electric drive: activate the drive lever.

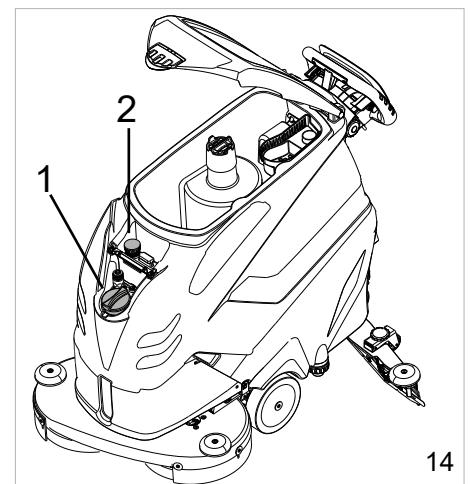
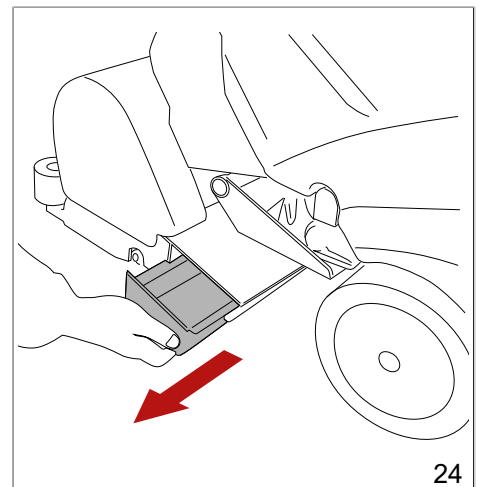
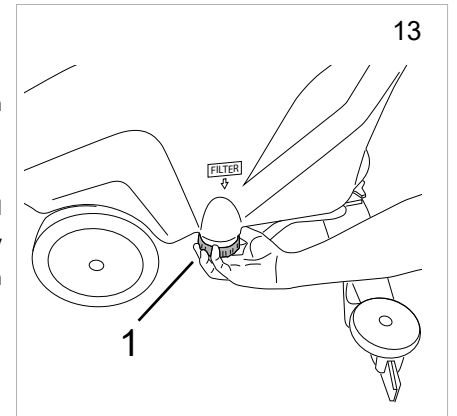
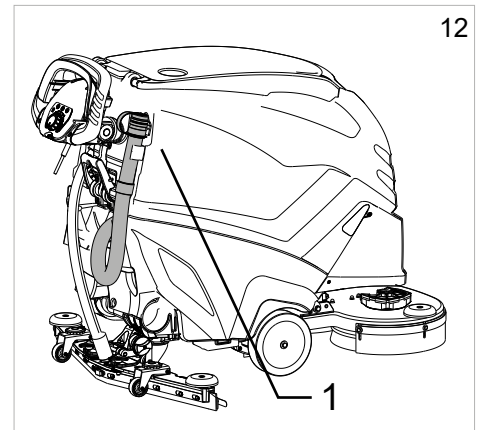

MAINTENANCE INSTRUCTIONS

! DANGER

Never perform any maintenance operations without first disconnecting the batteries.

Maintenance on the electrical circuit and all other operations not explicitly described in this manual must be performed by specialised personnel only, in compliance with current safety legislation and as described in the maintenance manual.

! DANGER

Before lifting/rotating the tank to access the compartment, its contents must first be emptied, then insert the safety bracket in position to prevent the tank from accidentally closing again, see chapter "SAFETY INFORMATION".

Maintenance - General rules

Performing regular maintenance according to the Manufacturer's instructions improves performance and extends the working life of the machine.

When cleaning the machine, observe the following precautions:

- ▶ Avoid using pressure washers. Water could penetrate the electrical compartment or motors leading to damage or short circuits.
- ▶ Do not use steam to avoid the heat warping plastic parts.
- ▶ Do not use solvents or hydrocarbon based products. These can damage the cowlings and rubber components.

Cleaning the suction motor air filter

Open the lid of the dirty water tank by releasing the clamp lever, then remove the filter from its housing (fig. 15 - Ref 1) and wash it under running water or using the detergent dispensed by the machine; dry the filter thoroughly before repositioning it in the housing.

Cleaning the debris container

Open the dirty water tank lid, then empty the debris accumulated in the container (fig. 15-ref. 2); if needing to wash the container, remove it by lifting it out and then clean it.

Cleaning the dirty water tank float

Open the dirty water tank lid, then remove the debris container by lifting it out (fig. 15-ref. 2), turn the float protector (fig. 15-ref. 3) and then clean the float; make sure that the float slides freely on its pin.

Cleaning the water/detergent tank filter

To clean the filter, proceed as follows:

- ▶ Unscrew the filter cap (fig. 17-ref. 1), remove the filter/hose union (fig. 17-ref. 2), then wash under running water or using the same detergent as used on the machine.
- ▶ Replace the filter in its housing, making sure it is correctly positioned and screw the cover back on.

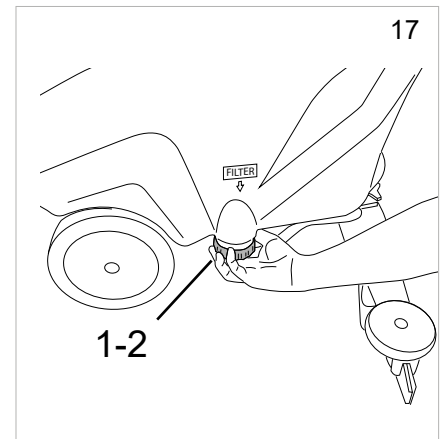
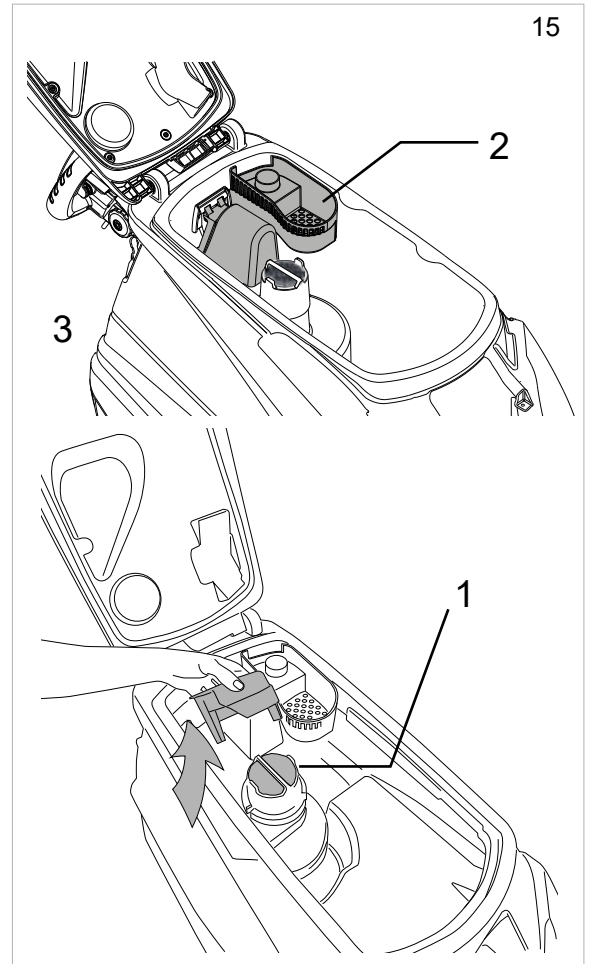

Fuses: replacing

! WARNING

Never use a fuse with a higher amperage than specified.

The fuses can only be replaced by an IP Cleaning service centre or by technical personnel authorised by IP Cleaning.

Lift the tank, disconnect the battery wiring connector from the electrical system or unplug the power cable, remove the cover (Fig. 18-Ref. 1) to access the fuses.

Battery maintenance and charging

! INFORMATION

Before charging the batteries, remove the electronic key from the instrument panel.

! DANGER

Do not check the batteries by sparking.

The batteries (WET) give off flammable fumes. Put out all fires and hot embers before checking or topping up the battery level.

! DANGER

Perform the operations described below in a ventilated area.

! WARNING

When charging the batteries, the tank must be lifted and kept open, to allow correct ventilation of the battery compartment.

! WARNING

In the case of gel batteries, use a specific charger for gel batteries only.

! WARNING

To avoid permanent damage to the batteries, do not run them down completely.

! WARNING

Charge the batteries as instructed in the battery charger manual.

Disconnect the connectors at the end of charging.

! DANGER

Before releasing the screw ring on the tank opening cable, which is only permitted for battery installation/replacement and for checking/restoring the level of sulphuric acid solution, make sure that the machine is standing on a perfectly horizontal surface.

After completing the above operations, hook the screw ring into the loop indicated by the black arrow (see figure below) and secure the screw of the carabiner with a hexagonal spanner so that it cannot be opened manually afterwards.

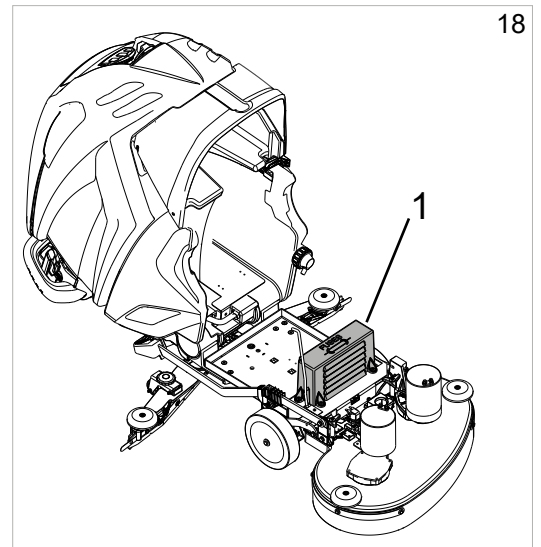

“STANDALONE” battery charger, electrical connection to the machine:

- ▶ Turn the machine off.
- ▶ Plug the battery charger connector into the socket on the machine as highlighted (fig. 19-ref. 1).
- ▶ Start the recharge cycle.
- ▶ Disconnect the connectors at the end of charging.

“ONBOARD” battery charger:

- ▶ Turn the machine off.
- ▶ Unplug the battery charger from the socket (fig. 19-ref. 2).
- ▶ Plug into the mains socket.
- ▶ Start the recharge cycle.
- ▶ The display will show when the recharge cycle ends, see “Display alarms”
- ▶ At end of the recharge cycle, unplug the cable from the power socket.

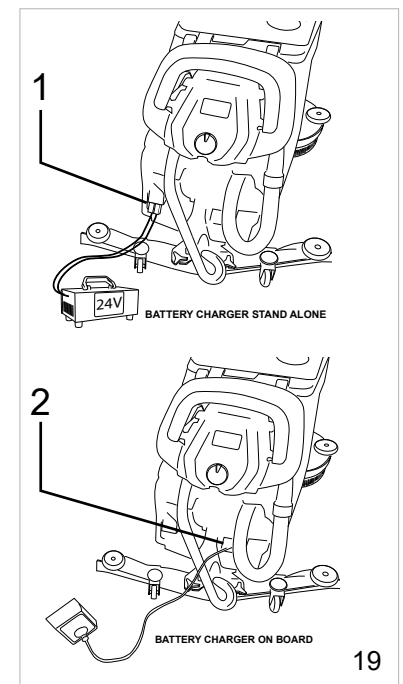

Replacing the squeegee blades

- ▶ Lower the squeegee.
- ▶ Remove the suction hose from the squeegee
- ▶ Lift the squeegee fastening levers.
- ▶ Remove the squeegee from the slots on the support.
- ▶ Open the hook (fig. 20, ref. 1).
- ▶ Push the two blade pressing devices (fig. 20, ref. 2) outwards, then remove them.
- ▶ Remove the blade.
- ▶ Reuse the same blade by reversing the edge in contact with the floor until all four edges are worn out, or replace with a new blade, fitting it onto the screws on the body of the squeegee.
- ▶ Reposition the two blade pressing devices by centering the wider part of the slots on the squeegee body fastening pins, then push the blade pressing devices inwards.
- ▶ Close the hook again.
- ▶ Replace the squeegee on its support, following the instructions described previously.

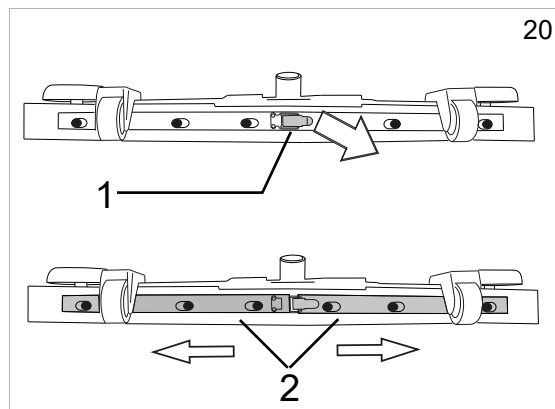

Periodic checks

CHECKS	DAILY OPERATIONS	WEEKLY OPERATIONS	SIX MONTHLY OPERATIONS
EMPTY AND WASH THE DIRTY WATER TANK	X		
CLEAN THE SQUEEGEE BLADES AND CHECK THEM FOR WEAR	X		
CHECK THAT THE SUCTION HOLE IN THE SQUEEGEE IS NOT BLOCKED	X		
RECHARGE THE BATTERIES	X		
CLEAN THE DIRTY WATER TANK FLOAT		X	
CLEAN THE SUCTION MOTOR AIR FILTER		X	
CLEAN THE WATER/DETERGENT TANK FILTER		X	
CLEAN THE SUCTION MOTOR HOSE		X	
CLEAN THE DIRTY WATER TANK AND THE SOLUTION TANK		X	
CHECK THE BATTERY ELECTROLYTE LEVEL		X	
HAVE THE ELECTRICAL CIRCUIT CHECKED BY QUALIFIED IP CLEANING PERSONNEL			X

PERIODS OF INACTIVITY

If the machine is not used for some time, for example, on display in a showroom or stored in the warehouse for a period or more than one month, the following operations are required:

- ▶ Recharge completely the batteries. During long periods of inactivity, you should charge the batteries regularly (at least once every two months) to keep them constantly at maximum charge.
- ▶ Disconnect the batteries from the machine.
- ▶ Unplug the battery charger (if present) from the mains power supply.
- ▶ Remove the squeegee and brushes (or abrasive disks), wash them and put them away in a dry place (preferably in a bag or wrapped in plastic film) away from dust.
- ▶ Make sure the tanks are completely empty and perfectly clean.

! WARNING

If the batteries are not recharged regularly as described above, they may be irrevocably damaged.

The manufacturer is not liable for any malfunctions resulting from neglect, improper and/or incorrect use.

! WARNING

When the batteries are flat, make sure they are not left for an extended time without charging to avoid shortening battery life.

Check battery charge at least once a week.

TROUBLESHOOTING

B = 24 Vdc battery version

BT = 24 Vdc battery version with electric drive

C = 100-115-230 Vac cable version

PROBLEM	CAUSE	REMEDY
The machine does not work	The batteries are disconnected (B-BT)	Connect the batteries to the machine
	The batteries are flat (B-BT)	Recharge the batteries
	Blown fuse (B, BT-C)	Replace
	Electronic key not inserted (B-BT-C)	Engage.
	Power cable unplugged from the power socket (C)	[C]= plug into the mains socket
The brushes do not turn	The dirty water tank is full (B, BT-C)	Empty the dirty water tank
	Blown fuse (B, BT-C)	Replace
	Relay damaged (B-BT-C)	Replace
	The batteries are flat (B-BT)	Recharge the batteries
	Motor damaged (B, BT-C)	Replace
The machine does not clean uniformly	The brush or abrasive disks are worn(B-BT-C)	Replace
No solution comes out of the detergent tank	Solenoid valve damaged (B-BT-C)	Replace
	Solenoid valve dirty (B-BT-C)	Check
	The detergent tank is empty (B-BT-C)	Top up
	The hose delivering detergent to the brush is blocked (B-BT-C)	Unblock
	Blown fuse (B, BTC)	Replace
Detergent flow does not stop	Solenoid valve damaged (B-BT-C)	Replace
	Solenoid valve wiring damaged (B-BT-C)	Check
The suction motor does not start	The dirty water tank is full (B, BT-C)	Empty the dirty water tank
	Blown fuse (B, BT-C)	Replace
	Squeegee lever raised (BT)	Lower
	The batteries are flat (B-BT)	Recharge the batteries
	Motor damaged (B, BT-C)	Replace
The squeegee does not clean or has poor suction	The edge of the rubber blades in contact with the floor is worn	Replace the blades
	Blockage or damage in the squeegee (B-BT-C)	Check
	The dirty water tank float is activated or is blocked by dirt, or is faulty (B-BT-C)	Empty the dirty water tank, check the float
	Blockage in the suction hose (B, BT C)	Check
	The suction hose is not connected to the squeegee or is damaged (B-BT-C)	Check
The machine does not move	The batteries are flat (B-BT)	Recharge the batteries
	Damaged motor (BT)	Replace
The batteries do not provide the normal working time	The battery poles and charging terminals are dirty and oxidised (B-BT)	Clean and grease the poles and terminals, charge the batteries
	The battery charger does not work or is not suitable (B-BT)	Check



DISPLAY ALARMS

Alarm	Possible cause	What to do
BRUSHES THERMAL PROTECTION	The brush motor has overheated. Faulty thermal protector contact on the motors. Faulty connection.	Wait for the brush motors to cool down. Replace the brush motor. Check the connection.
DRIVE THERMAL PROTECTION	The drive wheel has overheated. Faulty thermal protector contact on the motor. Faulty connection.	Wait for the drive wheel to cool down. Replace the drive wheel. Check the connection.
WATER RESERVE	Solution tank almost empty. Stuck sensor. Faulty sensor or connection.	Fill the solution tank. Clean the level sensor. Replace the level sensor. Check the connection.
NO WATER	Solution tank empty. Stuck sensor. Faulty sensor or connection.	Fill the solution tank. Clean the level sensor. Replace the level sensor. Check the connection. To resume work, turn the operation selector to the OFF position (reset errors).
DIRTY WATER TANK	Dirty water tank full. Stuck sensor. Faulty sensor or connection.	Empty the dirty water tank. Clean the level sensor. Replace the level sensor. Check the connection. To resume work, turn the operation selector to the OFF position (reset errors).
CHEMICAL FINISHED	Chem-Dose tank empty. Stuck sensor. Faulty sensor or connection.	Fill the Chem-Dose tank. Clean the level sensor. Replace the level sensor. Check the connection.
FUNCTION BOARD NOT DETECTED	Communication with functions board interrupted. Faulty auxiliary boards.	Check the connection between the boards. Check the auxiliary boards.
BATTERY RESERVE	Battery voltage less than : 21.9 V GEL/AGM - 21 V ACID. Flat batteries.	Recharge the batteries. Replace the batteries.
CALL SERVICE	The set number of hours for scheduled service have been reached/exceeded.	Call a service centre to arrange servicing.
BATTERY CHARGING	The on-board battery charger is operating, all the machine's functions are disabled.	Disconnect the battery charger.
CHARGING COMPLETE	The on-board battery charger is operating, the charge is complete, all the machine's functions are disabled.	Disconnect the battery charger.
O.C. BRUSHES	Excessive motor effort. Faulty functions board. Brush motor faulty	Check motor load. Replace functions board. Replace the brush motor.
DRIVE BOARD TEMPERATURE	Excessive vehicle effort. Faulty drive board. Electric brake engaged.	Cool or heat the board. Do not overwork the machine on long ramps. Replace the drive control board. Check the electric brake.
ACCELERATOR FAULT	Faulty potentiometer connections. Faulty potentiometer.	Check the connection. Replace the potentiometer.
DRIVE BOARD U.V.	Battery voltage less than 18.3 V GEL/AGM - 18 V ACID. Flat or degraded batteries.	Charge or replace the batteries.
RELAY FAULT	Faulty relay. Faulty relay connection.	Replace the relay. Check relay connections.
ELECTRIC BRAKE FAULT	Faulty wiring. Faulty electric brake. The electric brake has been enabled in the Technical menu but it is not fitted on the machine.	Check the wiring. Check / replace the electric brake. Correct the settings in the Technical Menu.
HDP	Drive lever pressed when starting. Drive lever potentiometer not adjusted.	Release the drive lever when starting the machine. Check potentiometer adjustment.

BATTERY FLAT	Battery voltage less than 21.4 V - GEL / 20.5 V - ACID. Flat or degraded batteries.	Recharge the batteries. Replace the batteries.
TAG FAULT	Faulty key. Faulty instrument panel antenna board	Replace the key. Replace the instrument panel antenna board-reed. Check the wiring.
RFID FAULT	Faulty key. Faulty instrument panel antenna board	Replace the key. Replace the instrument panel antenna board-reed. Check the wiring.
SUCTION TEMPERATURE	Excessive motor effort. Faulty functions board. Faulty suction motor.	Check the suction motor. Replace functions board. Replace the suction motor.
BRUSH TEMPERATURE	Excessive motor effort. Faulty functions board. Faulty motor.	Check the motor. Replace functions board. Replace the motor.
SUCTION O.C.	Excessive motor effort. Faulty functions board. Faulty suction motor.	Check the suction motor. Replace functions board. Replace the suction motor.
DRIVE O.C.	Excessive vehicle effort. Faulty drive board. Electric brake engaged.	Check the motor. Replace the drive board. Check the electric brake.
UPDATE FW	Software update.	Do not remove the key during the update.
FLASHING LIGHT FAULT	Faulty wiring. Faulty flashing light. The flashing light is broken. The flashing light has been enabled in the Technical menu but it is not fitted on the machine.	Check the wiring. Check the flashing light. Replace the flashing light. Correct the settings in the Technical Menu.
SOLENOID VALVE FAULT	Faulty wiring. Faulty solenoid valve. Solenoid valve broken.	Check the wiring. Check the solenoid valve. Replace the solenoid valve.
PUMP FAULT	Faulty wiring. Faulty pump. The pump is broken. The pump has been enabled in the Technical menu but it is not fitted on the machine.	Check the wiring. Check the pump. Replace the pump. Correct the settings in the Technical Menu.
BRUSHES FUSE	Excessive motor effort. Faulty brush motor contactor. Motor fuse blown.	Check the motor. Replace the contactor. Replace the fuse.
SUCTION FUSE	Excessive motor effort. Faulty brush motor relay. Motor fuse blown.	Check the motor. Replace the relay. Replace the fuse.
RECHARGE ERROR	Generic error associated with the battery recharging operation.	Disconnect the battery charger and repeat the recharge procedure. If the problem persists, replace the battery charger.



TECHNICAL MENU CT51 - 71

Access the menu by turning the operation selector to OFF and pressing "SET" twice, then press the "+" and "-" buttons together.

The "+" button increases the selected parameter or the variable relating to the selected parameter.

The "-" button decreases the selected parameter or the variable relating to the selected parameter.

The "SET" button selects the parameter to be set and confirms the entered variable.

B-C

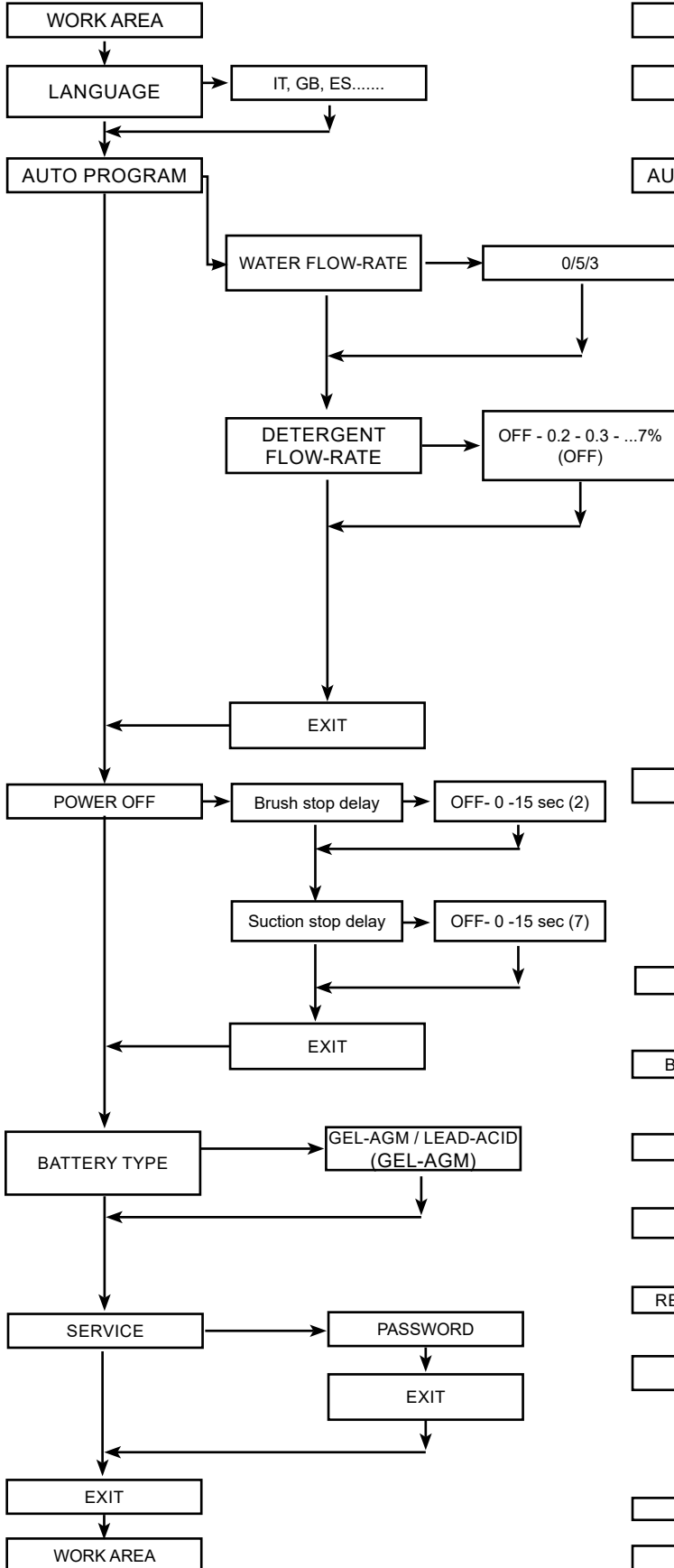

BT-XP

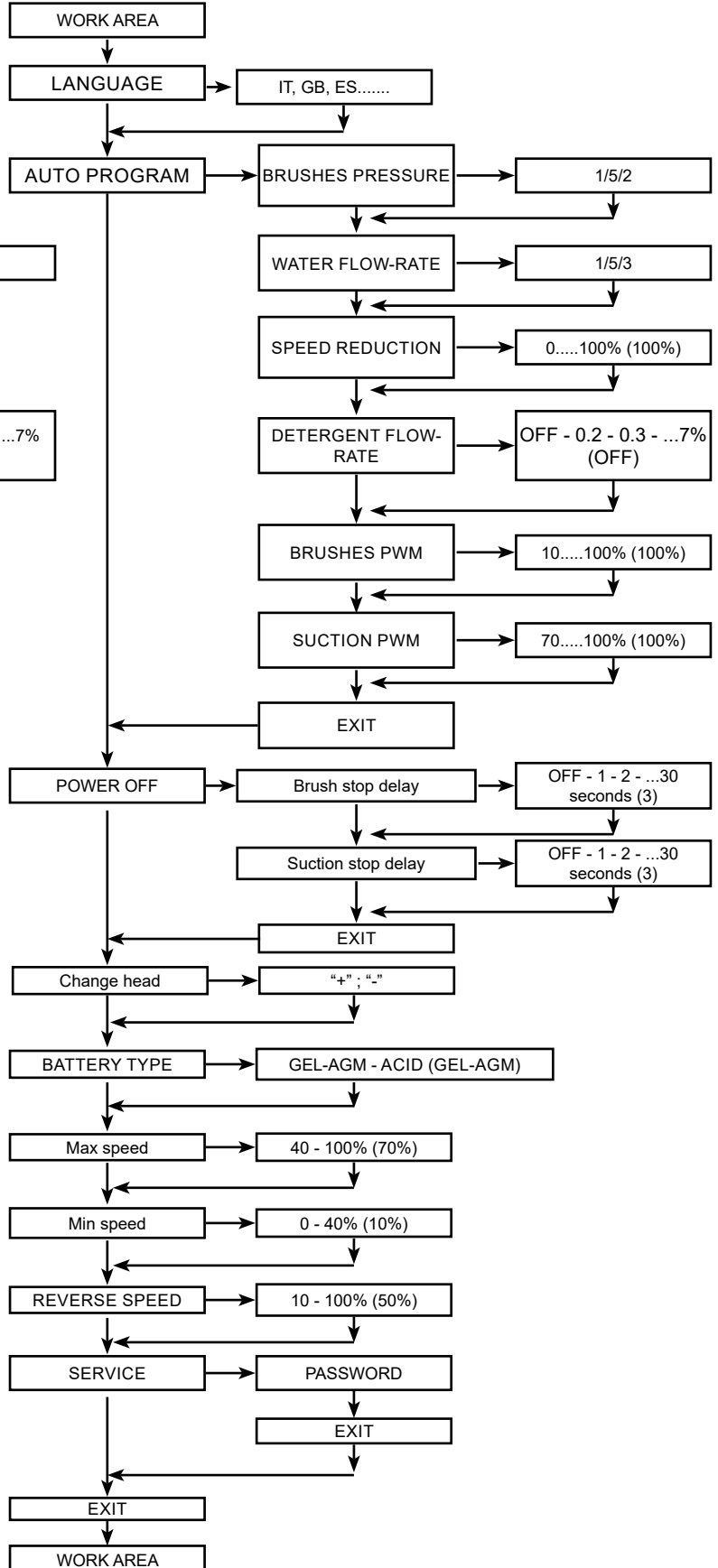



IP Cleaning S.r.l.
Viale Treviso 63
30026 Summaga di Portogruaro
Venezia (Italy)
T: +39 0421 205511
F: +39 0421 204227
E: www.ipcworldwide.com
W: info@ipcworldwide.com

