



IPC

1404 - LION 1460



(IT) MANUALE ISTRUZIONI PER L'USO / **(EN)** OPERATOR'S MANUAL /
(FR) MANUEL D'INSTRUCTIONS / **(DE)** BEDIENUNGSANLEITUNG /
(ES) MANUAL DE INSTRUCCIONES / **(NO)** BRUKERHÅNDBOK /
(NL) GEBRUIKERSHANDLEIDING / **(PT)** MANUAL DE UTILIZAÇÃO /
(SE) INSTRUKTIONSBOK / **(RU)** РУКОВОДСТВО ОПЕРАТОРА /
(BG) РЪКОВОДСТВО ЗА ЕКСПЛОАТАЦИЯ

Consultare attentamente questo manuale prima di procedere a qualsiasi intervento sulla macchina
Read this manual carefully before carrying out any work on the machine
Lire attentivement ce manuel avant toute intervention sur la machine
Vorliegendes Handbuch vor jedem Eingriff an der Maschine aufmerksam durchlesen
Consulte detenidamente este manual antes de llevar a cabo cualquier trabajo en la máquina
Konsulter denne håndboken nøye før du går i gang med noen som helst type inngrep på maskinen
Raadpleeg deze handleiding aandachtig alvorens met enige werkzaamheid aan de machine te beginnen
Consulte atentamente este manual antes de efectuar cualquier intervención na máquina
Läs noggrant igenom denna handbok innan du utför något som helst ingrepp på maskinen
Внимательно ознакомьтесь с данной инструкцией до проведения любой работы с машиной
Прочетете внимателно това ръководство, преди да започнете работа с машината

TECHNICAL SPECIFICATIONS	2
SAFETY SYMBOLS.....	4
INTRODUCTION / GENERAL WARNINGS.....	5
INTRODUCTION	5
GENERAL DESCRIPTION	5
GENERAL SAFETY RULES.....	5
MODIFICATIONS AND IMPROVEMENTS	7
SAFETY	7
SERIAL NUMBER – CE MARKING	8
UNPACKING	8
THE CONTROLS AND THE CONTROL PANEL.....	8
PREPARING THE MACHINE	9
BATTERY REMOVAL	11
USING THE MACHINE	11
AUTO-POWER ON/OFF	12
WORKING.....	13
FURTHER PERFORMANCES OF THE MACHINE FEATURING AN ENGINE	14
SAFETY THERMOSTAT	14
EMPTYING THE DEBRIS BIN.....	15
CLEANING AND SERVICING THE FILTER.....	15
REPLACING/INSTALLING THE SIDE BRUSHES.....	16
REPLACING THE CENTRE BRUSH.....	17
BATTERY MAINTENANCE AND CHARGING	17
ADJUSTING THE SIDE BRUSHES FOR WEAR.....	18
ADJUSTING THE BRAKE.....	19
COMBUSTION ENGINE MAINTENANCE.....	19
AIR FILTER OF THE ENGINE	19
“CHANGE OIL” ALARM CODE	20
MAINTENANCE OF THE BATTERY VERSION	21
COMBUSTION ENGINE VERSION MAINTENANCE	22
DISPLAY ALARMS	23
DRIVE BOARD ALARMS	25
USER MENU	26
TECHNICAL MENU	26
TROUBLESHOOTING.....	27

TECHNICAL SPECIFICATIONS

		BATTERY	DUAL POWER PETROL	DUAL POWER DIESEL
Cleaning width	mm	800		
	inches	31,49		
Cleaning capacity per hour	m ² /h	8250 - 10500		
	ft ² /h	88802 - 113021		
Main brush motor power	W	500		
	HP	0,67		
Side brush motor power	W	60		
	HP	0,08		
Drive motor power	W	1000		
	HP	1,34		
Internal combustion engine starting	W	/	300	
	HP	/	0,4	
Internal combustion engine power	W	/	48470,5	73824,3
	HP	/	6,5	9,9
Fuel tank capacity	l	/	5	
	galls.	/	1,32	
Suction motor power	W	2X180		
	HP	2X0.24		
Panel filter shaker motor power	W	2X90		
	HP	2X0.12		
Alternator	A	/	80	
Maximum forward speed	km/h	6,5		
	mph	4,03		
Maximum reverse speed	km/h	3,4		
	mph	2,11		
Maximum negotiable gradient	%	20		
Debris bin capacity	l	150		
	galls.	39,62		
Rear wheel diameter	mm	315		
	inches	12,4		
Front wheel diameter	mm	315		
	inches	12,4		
Main brush diameter	mm	330		
	inches	13		

Side brush diameter	mm	510		
	inches	20.07		
Panel filter surface area	sq.m.	6		
	ft ²	64.58		
Gross weight	kg	765	647	675
	lbs			
Transported weight	kg	375	210	210
	lbs			
Number of batteries	no.	4	2	2
Battery voltage	V	6	12	12
Individual battery capacity	Ah (5h)	250	105	105
Power system voltage	V	24		
Machine dimensions	mm	1600X1080X1280		
	inches	63x42.5x50.4		
Battery compartment dimensions (length, width, height)	mm	480x370x360		
	inches	18.9x14.6x14.1		
Packed size (length, width, height)	mm	1870x1200x1500		
	inches	73.62x47.24x59.05		
Sound pressure	LpA (dB)	70	78	81
Measured sound power	Lwa (dB)	76	93	96
Guaranteed sound power	Lwa,g (dB)	77	93	97
Vibration level (hand)	HAV m/sec ²	1,8	2,1	2,3
Measurement uncertainty, k	m/sec ²	0,9	1,1	1,2
Vibration level (body)	HBV m/sec ²	0,5	0,7	0,8
Measurement uncertainty, k	m/sec ²	0,2	0,4	0,4









Gross weight (GVW): maximum permissible weight with the machine fully loaded and ready for use. The gross weight of the vehicle includes, when applicable, full clean water tanks, empty dirty water tanks (half full in the case of recycling systems), empty dust bags, the hopper filled to its rated capacity, the largest recommended batteries and all accessories such as cables, hoses, detergent, mops and brushes.

Transported weight: the weight of the machine including the batteries, but excluding optionals (for example, the operator's cabin, FOPS, second and third side brushes and front brush attachment), fresh water (in the case of scrubbers or combined machines) and the weight of a standard operator (75 kg).

Data subject to changes without prior warning

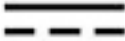

SAFETY SYMBOLS

	<p>WARNING! RISK OF ENTANGLEMENT</p>
	<p>WARNING! RISK OF ACID BURNS</p>
	<p>WARNING! RISK OF BURNS</p>
	<p>MAXIMUM SLOPE</p>
	<p>OPERATOR MANUAL, INSTRUCTIONS FOR USE</p>
	<p>READ THE OPERATOR'S MANUAL</p>
	<p>DIRECT CURRENT SYMBOL</p>
	<p>CLASS III APPLIANCE. AN APPLIANCE IS IDENTIFIED AS CLASS III WHEN ITS EXPLOSION-PROOF PROTECTION IS BASED ON THE FACT THAT THERE ARE NO VOLTAGES HIGHER THAN THE ULTRA-LOW SAFETY EXTRA-LOW VOLTAGE (SELV). THIS MEANS IN PRACTICE THAT THE APPLIANCE IS POWERED BY A BATTERY OR A SELV TRANSFORMER.</p>
	<p>SPECIAL WASTE. DO NOT DISPOSE OF AS NORMAL WASTE.</p>

INTRODUCTION / GENERAL

WARNINGS

This manual has been written by the Manufacturer and is an integral part of the [machine](#)¹.

It defines the purpose for which the machine has been designed and constructed and contains all the information required by [operators](#)².

In addition to this manual, which contains information for operators, other publications are available providing specific information for [maintenance personnel](#)³.

The terms "right" and "left", "clockwise" and "anti-clockwise" refer to the forward movement of the machine.

Constant compliance with the instructions provided in this manual guarantees the safety of the operator and the machine, ensures low running costs and high quality results and extends the working life of the machine. Failure to respect the instructions may lead to damage to the operator, machine, floor and environment.

Consult the table of contents at the beginning of the manual to find the section of interest without delay.

INTRODUCTION

This instruction handbook contains guidelines and practical information concerning the use, adjustment and routine maintenance of your new machine.

Your machine has been designed and built to offer the best in terms of performance, comfort and ease-of-use in a variety of different conditions. Before delivery, your machine has been checked at our factory and by our dealer to guarantee that it is handed over to you in perfect working order. To maintain the machine in this condition and ensure problem-free operation, strictly follow the instructions given in the handbook. Before attempting to use the machine, read this handbook and keep it to hand for any future consultation. For further information regarding the machine, do

The definition "machine" replaces the trade name covered by this manual.

Persons responsible for using the machine without performing any operations requiring precise technical skills.

Persons with experience, technical training and a knowledge of legislation and standards, able to perform all the necessary operations and to recognise and avoid possible risks in handling, installation, use and maintenance of this machine.

not hesitate to contact your dealer, who has competent maintenance staff, original parts and the equipment needed to respond to your needs.

NOTE: the machine version called DUAL POWER refers to the model equipped with an combustion engine and battery pack.

GENERAL DESCRIPTION

The machine described in this manual is a motorised sweeper designed to sweep floors in civil and industrial premises.

It may be used to clean the residues of industrial processes, dust and dirt in general on all relatively even, flat and hard surfaces such as concrete, asphalt, porcelain stoneware, ceramic tiles, sheet metal, marble, embossed or smooth rubber or plastic mats indoors or outdoors.

GENERAL SAFETY RULES

IMPORTANT: the following rules must be carefully observed to avoid harm to the operator and damage to the machine.

- Read the safety labels on the machine and do not cover them for any reason whatsoever. Replace them if they are damaged or become unreadable.
- The storage temperature ranges from 0° to + 50°C.
- The optimal working temperature should range from 0° and + 40°C.
- The ambient humidity must range from 0 to 95 %.
- The machine must be kept indoors at all times.
- The machine must be used exclusively by operators trained in its use and/or who have demonstrated their ability and have been expressly authorised to use it.
- The machine must not be used by minors.
- Always pay attention to other people, especially children, in the place where you are working.
- Children must be supervised to make sure they do not play with the machine.
- The machine is not intended for use by persons (including children) with reduced physical, sensory or mental capabilities, or lack of experience and knowledge, unless they are supervised by a person responsible for their safety and have received instruction in the use of the machine.
- Do not inhale exhaust gases. Use the

machine indoors only when sufficient ventilation can be guaranteed and when there is another person on stand-by, ready to assist in situations of potential danger.

- Do not bump against shelves or scaffolding when there is a risk of objects falling over.
- In areas where the operator could be struck by objects falling from overhead, do not use the machine without a FOPS (Falling Object Protective Structure)
- Do not use the machine as means of transport.
- Never use the machine to clean up flammable or explosive liquids (e.g. petrol, fuel oil, etc.), acids or solvents (e.g. paint solvents, acetone etc.) even if diluted.
- Never clean up burning or incandescent objects.
- Adapt the speed of the machine to the conditions of adherence to the floor.
- Avoid using the machine if its stability is not guaranteed.
- In the event of fire, use a powder fire extinguisher, DO NOT USE WATER.
- Do not use solvents or similar substances to clean the machine.
- Do not wash the machine by spraying directly with water or using high pressure water jets.
- Do not remove any guards that require the use of tools to be removed.
- NEVER use the machine without its guards. For your safety, make sure all guards are closed or correctly mounted before starting the machine.
- If you notice that the machine is not working properly, make sure this does not depend on failure to carry out the routine maintenance operations. If this is not your case, contact unauthorised service centre.
- Always use the battery charger supplied by the manufacturer, or alternatively, a charger bearing the CE mark and certified by a third party body in accordance with the latest edition of the pertinent standard (EN 60335-2-29). The charger must be equipped with double or reinforced insulation between input and output and with a SELV type output circuit with maximum 24V output voltage.
- Make sure the battery charger is compatible with the batteries to be charged.
- Make sure that the power socket used for the battery charger is connected to a suitable earth system and protected by thermal overload and residual current circuit breakers.
- Make sure the electrical characteristics of the battery charger (voltage, frequency, absorbed power) given on the rating plate are the same as those of the mains power supply.
- Check the battery charger power cable regularly for damage. If the power cable is damaged, do not use the charger.
- If replacing parts, order ORIGINAL spare parts from an authorised dealer or reseller.
- Maintenance operations on the electrical circuit and in any event all other operations not explicitly described in this operating manual must be performed by maintenance personnel only, in compliance with current safety regulations and as indicated in the maintenance manual.
- Always disconnect the power supply to the machine before carrying out any maintenance.
- Every 200 hours of work, have the machine checked by an authorised service centre.
- The product is classified as WEEE type special waste and is covered by the requisites of the new environmental protection regulations (2002/96/EC WEEE). It must be disposed of separately from ordinary waste in compliance with current legislation and standards.

MODIFICATIONS AND IMPROVEMENTS

Our company aims to constantly improve its products, and consequently reserves the right to make any changes and improvements when deemed necessary, without having to apply such to any machines sold previously.

SAFETY

You too can help avoid accidents.

No accident prevention program can be effective without the full cooperation of the operator directly responsible for operation of the machine.

Most accidents that occur in a company, during work or transport are caused by failure to observe the basic rules concerning safety.

A careful and prudent operator is the best guarantee against accidents and proves more effective than any prevention program.

During work, pay attention to the persons standing in the area to clean, especially children.

SERIAL NUMBER – CE MARKING

Make sure that the machine is equipped with a rating plate showing the serial number and CE mark, positioned as shown in (fig. 1). If this is not the case, notify the dealer immediately.

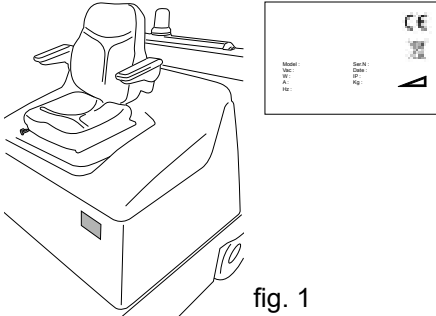

UNPACKING

Unpack your machine with great care, avoiding any manoeuvre that could lead to damage. Once you have unpacked it, make sure all parts are in a good condition. If you notice any damage, DO NOT use the machine and contact your retailer immediately. Due to packaging and transport requirements, some parts and optionals may be supplied separately; for correct assembly, follow the instructions given in the corresponding chapters of this booklet.

Contents of the package

- Side brush
- Ignition key
- User and maintenance manual
- Declaration of conformity
- Warranty coupon
- Batteries (if required)
- Battery connection kit
- Battery charger (if required)

If you notice that any of the above are missing, contact your retailer immediately.

NOTE: To avoid losing it during transport, the ignition key is placed inside the bag containing the technical documents.

Make sure the packaging materials (bags – cartons – pallets – hooks – etc.) are put away, out of the reach of children.

To simplify transport, the side brush/brushes are not mounted in the position intended for machine operation; assemble as described in the chapter “REPLACING/INSTALLING THE SIDE BRUSHES”.

THE CONTROLS AND THE CONTROL PANEL

- Brake lock pedal and service brake pedal (fig. 2, ref. 1).
- Raise flap pedal (fig. 2, ref. 2), pressing this allows the centre brush to pick up bulky objects.
- Accelerator pedal (fig. 2, ref. 3).
- Right side brush control lever (fig. 2, ref. 4), used to lower or raise the side brush.
- Left side brush control lever (fig. 2, ref. 4A), used to lower or raise the side brush.
- Seat adjustment lever (fig. 2, ref. 5).

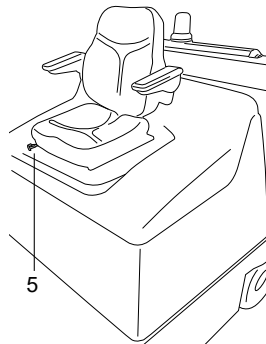
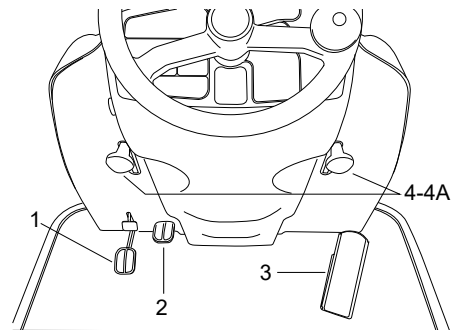

- Display button, selects the data shown on the display (fig. 3, ref. 1).
- Display (fig. 3, ref. 2):
- Button P1, select work program 1 (fig. 3, ref. 3).
- Button P2, select work program 2 (fig. 3, ref. 4).
- Button P3, select work program 3 (fig. 3, ref. 5).
- Filter shaker activation button (fig. 3, ref. 6):
- Suction activation button (fig. 3, ref. 7):
- Knob for adjusting the speed of the side brushes (fig. 3, ref. 8).
- Combustion engine start/stop button (fig. 3, ref. 9).
- Ignition key (fig. 3, ref. 10):
- Horn button (fig. 3, ref. 11):
- Light switch (fig. 3, 12) OPTIONAL.
- Emergency button (fig. 3, ref. 13):
- Knob for adjusting the maximum speed (fig. 3, ref. 14).
- Drive board alarm indicator light; the frequency at which the LEDs light up indicates the error code. In the absence of malfunctions, the status LED is on steady while the machine is operating (fig. 3, ref. 15).
- Machine direction selector (fig. 3, ref. 16).
- Raise bin control button (fig. 3, ref. 17).
- Lower bin control button (fig. 3, ref. 18)
- Tip bin control button (fig. 3, ref. 19)
- Fuel reserve indicator light (fig. 3, ref. 20)
- Oil alarm indicator light (fig. 3, ref. 21)
- Button for raising, lowering and tipping the bin (fig 3, ref. 22).

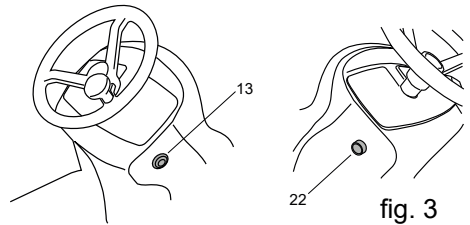
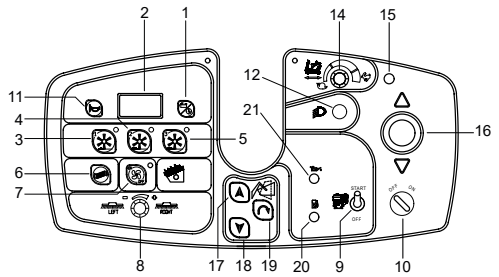

fig. 3

PREPARING THE MACHINE

WARNING: Competent battery specialists should preferably be contacted to choose and install the new batteries.

Two different types of battery may be installed on these machines:

- Leak-proof tubular batteries: these require regular checks on electrolyte level. When necessary, top up with distilled water until the plates are covered. Do not over-fill (5 mm max. above the plates).
- Gel batteries: this type of battery requires no maintenance.

Leak-proof tubular batteries are normally supplied filled with acid and ready for use. If the batteries in use are dry charged, they must be activated before being installed in the machine. Proceed as follows:

Remove the caps and fill all elements with sulphuric acid solution specific for batteries until the plates are entirely covered (this requires at least a couple of passes for each element).

Leave the batteries to stand for 4-5 hours to allow air bubbles to come to the surface and the plates to absorb the electrolyte.

Make sure the level of electrolyte is still above the plates and if necessary top up with sulphuric acid solution;

Close the caps.

Take special care when working with sulphuric acid, as it is corrosive. Observe the following precautions:

- Contact with the skin can cause irritation; wash with soap and water.
- Inhalation of vapours can cause irritation to the airways; stay out in the open air and consult a doctor.
- Contact with the eyes can cause irritation; flood the eyes with water immediately and thoroughly for at least 15 minutes, and consult a doctor.

Install the batteries in the machine (following the procedure described below).

It is recommended to perform a first top-up before starting the machine; for this operation see the chapter "BATTERY MAINTENANCE AND CHARGING" and the battery instruction booklet.

Lift the cowling toward the steering wheel of the machine, and locate the batteries in the compartment, positioning them as indicated in the drawing (fig. 4).

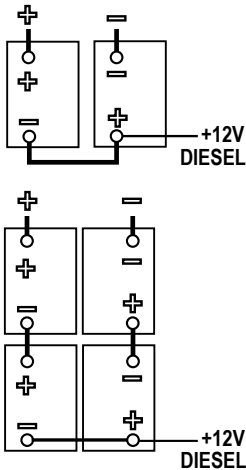

fig. 4

The electrical connection cables supplied with the machine may be used to connect the batteries.

IMPORTANT: in the battery compartment on the DUAL POWER version equipped with the DIESEL engine, there is a red wire marked with the label "+ 12V"; this wire must be connected to the +12V battery pole (starter motor power supply).

With the batteries installed, plug the battery connector into the machine (fig. 5).

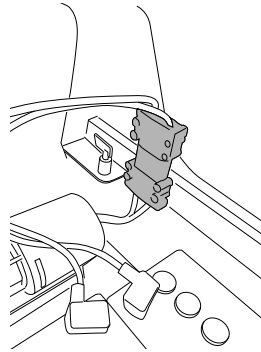

fig. 5

NOTE: when the batteries are installed, set the language to be used for the messages shown on the display in the machine's software menu; see the chapter "USER MENU".

NOTE: with the batteries installed, set the type of battery selected in the machine's "TECHNICAL MENU"; see the chapter "TECHNICAL MENU".

For the combustion engine version, fill the fuel tank: the type of fuel is specified on a label near the fuel cap (fig. 6).

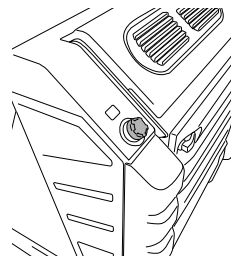

fig. 6

Check the engine oil level (see the chapter "COMBUSTION ENGINE MAINTENANCE"). Climb onto the machine and adjust the seat as desired (fig. 7).

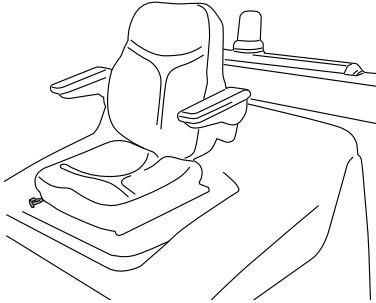

fig. 7

BATTERY REMOVAL

IMPORTANT: when removing the batteries, operators must use the necessary equipment (gloves, goggles, protective overalls, safety shoes, etc.) to limit the risk of accidents.

Check that all the switches on the control panel are in position "0" (off) and that the machine is switched off, away from any naked flames; do not short-circuit the battery poles, do not cause sparks and do not smoke, and proceed as follows:

- disconnect the battery wiring and bridge terminals from the battery poles.
- if necessary, remove the devices fixing the battery to the base of the machine.
- lift the batteries from the compartment using suitable lifting equipment.

WARNING: When disposing of the batteries, ensure compliance with local by-laws or regulations.

USING THE MACHINE

Insert the ignition key (fig. 8), turn it clockwise: the display will show all zeros for about 3 seconds, after which the battery voltage value will be shown.

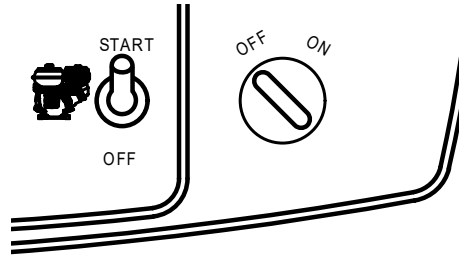

fig. 8

NOTE: in the operator's seat is a safety device that prevents drive (forward and backward) when the operator stands up from the seat.

NOTE: temporary activation of the indicator lights on the console and of the horn is to be considered normal.

Let at least three seconds pass after you have turned off the machine, before turning it on again.

Check the battery charge shown on the machine's display.

The display has two functions: Voltmeter and Hour meter.

The voltmeter incorporates an undervoltage shutdown function that automatically disables all services except for drive when the battery drops to a voltage of 20.5V (the BATTERY DISCHARGED error code flashes on the display).

In this case, recharge the battery (see the chapter "BATTERY MAINTENANCE AND CHARGING" and the battery user manual). If the batteries are sufficiently charged, work can now resume.

If the machine features a petrol engine, first start the engine.

IMPORTANT: DUAL POWER version equipped with DIESEL engine, during operation with the combustion engine off, the “OIL ALARM” light remains on (fig. 9); this is normal.



fig. 9

IMPORTANT: the “OIL ALARM” indicator light (fig. 9) comes on when ignition is started; on ignition the engine starts and the indicator light goes off. If the light comes on when driving, stop the machine and check the engine oil level.

To start the combustion engine, push the selector to the START position (fig. 10), the lever returns automatically.

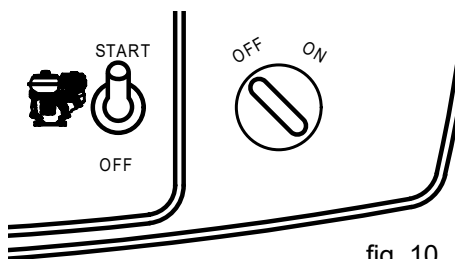

fig. 10

If the combustion engine does not start immediately, the starter motor must not be engaged for more than 5 seconds. This interval can be repeated after a short rest period (about 8 - 10 seconds).

To stop the engine, turn the selector back to the OFF position. In the event where the alternator overheats, there is an overtemperature protection device that stops the machine; the “PAUSE MOTOR” error code will be shown on the display

To start the machine, select forward or reverse gear using the selector (fig. 11).

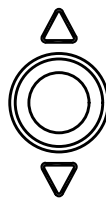

fig. 11

NOTE: if needing to push the machine when off or without the batteries, turn the appropriate key to disengage the electric drive motor; this will disable the machine’s automatic braking function (fig. 12).

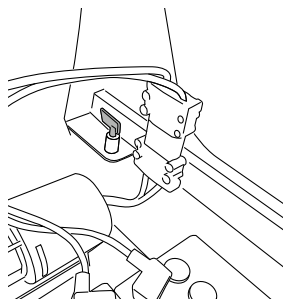

fig. 12

AUTO-POWER ON/OFF

The machine is equipped with an automatic system for switching the functions on or off. Selecting one of the three work programs, P1, P2 or P3 temporarily activates the following functions: centre brush, suction, side brushes; the LED for the selected program lights up together with the centre brush LED.

If the accelerator pedal is not pressed, after a few seconds the functions will stop and the LEDs will start flashing: the machine is now in AUTO-POWER-OFF mode.

All of the functions are automatically reactivated whenever the operator presses the accelerator pedal.

By releasing the accelerator, all the functions, except for the combustion engine, are automatically deactivated.

NOTE: the “AUTO-POWER ON/OFF” system can be disabled in the machine’s software menu; see the chapter “USER MENU”.

WORKING

IMPORTANT: do not inhale exhaust gases. Use the machine indoors only when sufficient ventilation can be guaranteed and when there is another person on stand-by, ready to assist in situations of potential danger.

IMPORTANT: in areas where the operator could be struck by objects falling from overhead, do not use the machine without a FOPS (Falling Object Protective Structure)

IMPORTANT: do not drive the machine with the bin raised, except when approaching or moving away from the garbage container.

Once the machine has been switched on, select the most suitable of the three work programs for cleaning by pressing one of the three buttons.

BUTTON P1 (light interior cleaning of quartz concrete, smooth floors, etc.) (fig. 13).

BUTTON P2 (cleaning carpets or other surfaces) (fig. 13).

BUTTON P3 (heavy exterior cleaning, asphalt or uneven surfaces with large debris, etc.) (fig. 13).

NOTE: the working parameters for programs 1 - 2 - 3 are preset by the manufacturer; to change the values contact the dealer.



fig. 13

Adjust the maximum drive speed according to the working conditions by turning the knob (fig. 14).

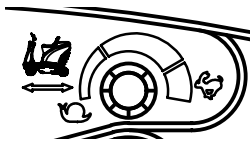

fig. 14

Lower the left and/or right side brush by pulling the appropriate levers up or down (fig. 15).

NOTE: the respective left and/or right indicator light will light up on the control panel.

NOTE: a resettable fuse is fitted above each side brush lever. If a side brush stops working, press the button to reset the fuse (fig. 15, rif. 1).

To return the side brushes to the OFF position, lift the two levers upwards.

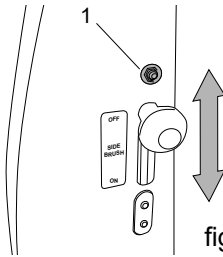

fig. 15

The speed of the side brushes can be adjusted by turning the knob (fig. 16).



fig. 16

The machine is equipped with an emergency stop button (fig. 17); pressing this button immediately stops all of the functions. To reactivate the machine, release the button, then activate the desired functions.

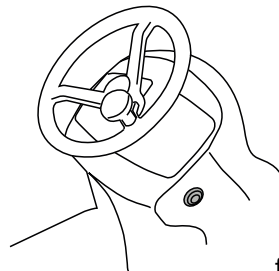

fig. 17

If needing to work on damp ground, in order to protect the paper filters, it is essential to stop the suction motor by pressing the suction button (fig. 18).



fig. 18

When work is finished, deselect the work program used (1-2-3) and switch off the machine.

Before leaving the machine, make sure that the side brushes are raised from the floor, the parking brake is engaged and that the ignition key has been taken out of the instrument board.

FURTHER PERFORMANCES **OF THE MACHINE** **FEATURING AN ENGINE**

The version featuring an engine can guarantee the same working efficiency even when the motor is off, for instance when the fuel has run out or when working in closed environments. Operating autonomy in this case will depend on the capacity of the batteries installed, on the intensity of the chosen work program and on initial battery charge.

To guarantee the working life of the batteries, the machine features some safety systems:

- when the battery voltage drops below 20.5 volts, all of the functions except for drive are automatically stopped. When this situation occurs, recharge the batteries or turn on the engine.
- Protection against battery overcharging: this machine, having a current generator with an electronic circuit that acts as a voltage regulator, ensures the batteries are correctly charged without damaging them due to excessive load. When the batteries are fully charged, this system automatically ensures no additional charge will be applied.

Based on tests carried out in the field and the results obtained on the energy balance of our hybrid system (DUAL POWER system), this can work in complete autonomy without the need to stop the machine and externally recharge the battery pack. Repeated tests with the three work programs (P1, P2, P3) on

asphalted surfaces and with normal working slopes have demonstrated that the machine operates in complete autonomy. However, being the machine designed also for heavy duty working conditions (slopes of over 20%, extremely rough surfaces to clean), the batteries may need to be recharged. In this case, it is advisable to use an electronic battery charger with a specific charge curve for the batteries installed.

SAFETY THERMOSTAT

The safety thermostat is located in the position shown.

If a fire starts inside the debris bin, the thermostat will stop the suction fan. Proceed as follows:

- take the machine to a safe area.
- open the debris bin and remove the heat source.

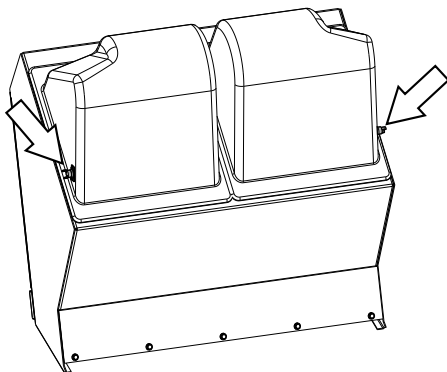

EMPTYING THE DEBRIS BIN

NOTE: to unload the debris bin, hold the control button, then choose the desired function.

- press the raise bin control button (fig. 19).
- move alongside the garbage container.
- press the tip bin button (fig 19).

NOTE: if the tip bin button is released, the bin will return to the horizontal position.

NOTE: the machine is equipped with a safety device that prevents the bin from rotating before reaching a safe distance from the machine.

- move away from the garbage container, then lower the bin.

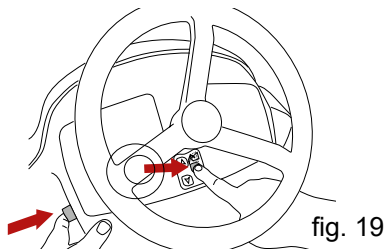
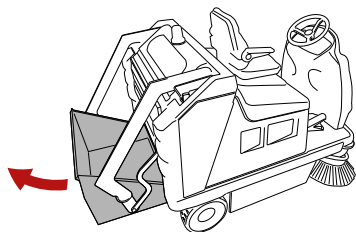
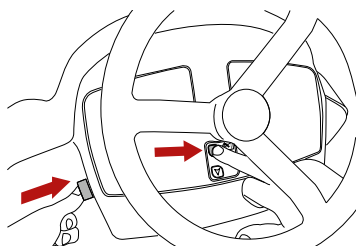
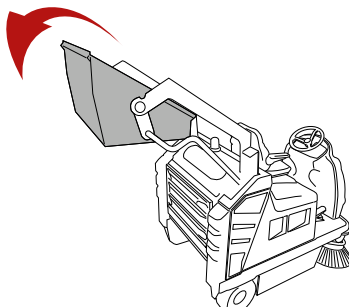

fig. 19



CLEANING AND SERVICING THE FILTER

The suction filter makes a major contribution to the efficiency of the whole machine.

Proper filter maintenance will allow you to obtain the best performance from your machine.

The suction filter can be cleaned as follows:

- using the automatic cleaning system; selecting the work program (P1-P2-P3) the machine is programmed for automatic and cyclical cleaning of the filter at pre-defined intervals.

NOTE: automatic cleaning can be enabled/disabled in the machine's software menu; see the chapter "USER MENU".

- using the manual cleaning system; press the filter shaker button (fig. 20) and hold it down for a few seconds.

Repeat this operation 4 or 5 times while using the machine.



fig. 20

This operation should be performed at the end of every working cycle. If the machine is used in a dusty environment (e.g. sawmills, warehouses where vehicles operate, etc.), make sure to use the filter shaker more frequently.

- manually cleaning the filter; if the filter shaker is not effective in cleaning the filter, and in any case every 20 operating hours, clean the filter manually. Before carrying out any type of work on the machine, make sure that it is switched off and that all of the functions are deactivated. To do this, turn the key

switch to the OFF position.

- remove the back panel from the machine (fig. 21).
- remove the two filters from their seat by turning locking restraining handles (fig. 21).
- blow the filter clean with compressed air (maximum pressure 6 bars).
- reassemble the two filters.
- close the back panel.

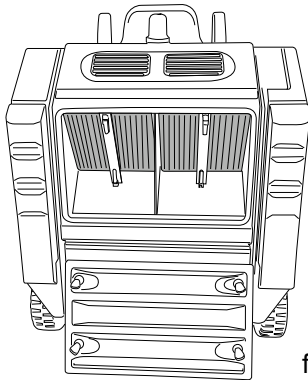

fig. 21

REPLACING/INSTALLING THE SIDE BRUSHES

To facilitate transport, the side brush (or brushes) is not fitted in its expected working position. To install the side brush in the correct position, proceed as follows:

- move the side brush control lever to the up position.
- unscrew the screw on the side brush motor shaft.
- remove the key protector.
- position the brush complete with flange on the shaft.
- tighten the brush locking screw again (fig. 22).

To replace worn side brushes, carry out the operations listed above.

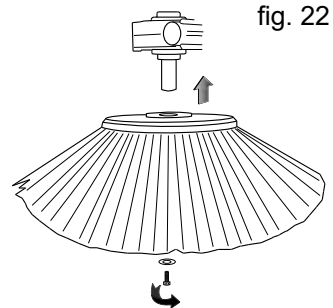

fig. 22

REPLACING THE CENTRE BRUSH

IMPORTANT: this operation must be performed with the machine switched off and the key removed..

This machine features a system for automatically adjusting the pressure exerted and compensating for the central brush wear. The need to replace the centre brush is indicated by the BRUSH WORN code on the display.

To replace the centre brush, proceed as follows:

- Unscrew the knob and open the door on the left of the machine (fig. 23).
- Unscrew and remove the three knobs fixing the brush compartment cover (fig. 23).
- Remove the cover of the brush compartment.
- Remove the worn brush (fig. 24).
- Remove the adapter from the core of the old brush and fit it to the new brush, taking care to keep the bristles aligned in the same direction (fig. 24).
- Fit the new brush and make sure that the adapter is inserted on the drive hub.
- Replace the brush compartment cover, following the dismantling operations in reverse order.

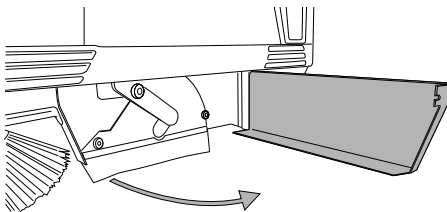

fig. 23

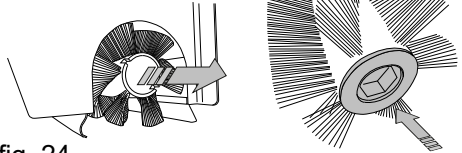
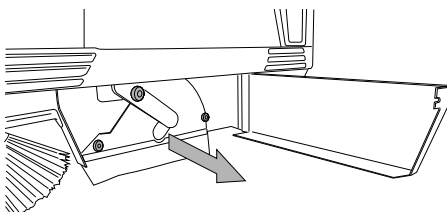

fig. 24

BATTERY MAINTENANCE AND CHARGING

WARNING: the use of an unsuitable battery charger can lead to dangerous situations! If in doubt, contact your local dealer.

IMPORTANT: make sure the battery charger is compatible with the batteries to be charged.

WARNING: Check the electrolyte level inside the leak-proof tubular batteries:

- every 30 hours for the battery version
- every week for the combustion engine version.

when necessary, top up with distilled water until the plates are covered; do not over-fill (MAX 5 mm above the plates).

The level of electrolyte is indicated in the battery instruction handbook.

After you have filled the battery, close the cells with their caps and clean the top surface.

The battery compartment is located under the operator's seat.

The battery is a sealed unit and guaranteed safe under normal circumstances; in the unlikely event of fluid leaking from the battery, do not touch the fluid and be sure to take the following precautions:

- Contact with the skin can cause irritation; wash with soap and water.
- Inhalation of vapours can cause irritation to the airways; stay out in the open air and consult a doctor.
- Contact with the eyes can cause irritation; flood the eyes with water immediately and thoroughly for at least 15 minutes, and consult a doctor.

When necessary, recharge the batteries according to the following instructions:

IMPORTANT: only recharge in a well-ventilated area.

- the machine must be switched off and the key removed.
- lift the cowl.
- unplug the battery connector from the machine (fig. 25).
- plug the battery connector into the charger (fig. 26).
- connect the battery charger to the mains.
- after charging, disconnect the batteries from the battery charger and reconnect them to the machine

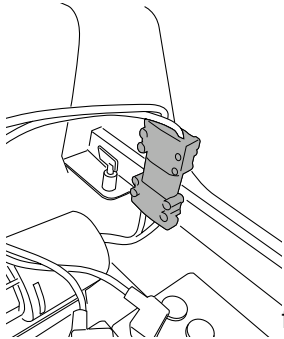

fig. 25

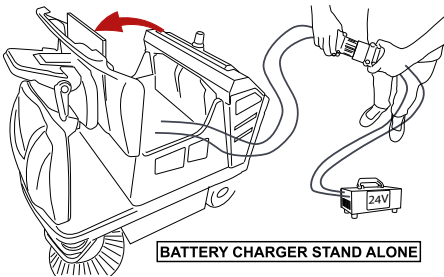

fig. 26

ADJUSTING THE SIDE BRUSHES FOR WEAR

If the side brushes (when lowered) do not touch the floor due to wear, they can be adjusted as follows:

- Move the side brush to the working position.
- Loosen the two adjustment screws underneath the brush levers (fig. 27).
- Manually move the brush to the required position.
- Tighten the adjustment screws.

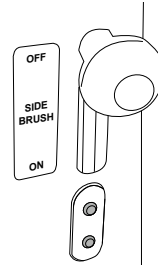

fig. 27

ADJUSTING THE BRAKE

When the effect of the service or parking brake action is too weak, it can be adjusted using the register "A+B"(fig. 28).

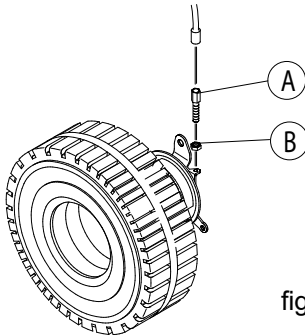

fig. 28

COMBUSTION ENGINE MAINTENANCE

NOTE: in addition to referring to the specific user and maintenance manual available on the manufacturer's website, below are some practical tips.

Check the engine oil level at least once a week using the dipstick (fig. 29); for topping up, use the oil specified below.

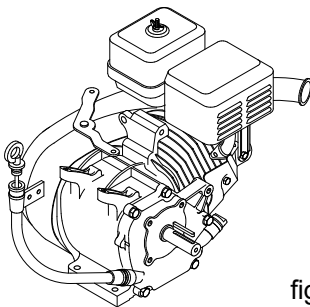

fig. 29

The engine oil must be changed the first time after 20 operating hours, or in any case after no more than 1 month. Subsequently, every 100 hours, or at most every 8 months.

To replace the oil in the engine, proceed as follows:

Remove the side sump on the right-hand side of the machine by unscrewing the fixing screws.

Gain access to the oil drainage pipe. Remove the dipstick to check the engine oil level.

Take the cap off the drainage pipe and let the exhaust oil drain out.

NOTE: it is recommended to drain the oil when the engine is hot.

Add the amount of new oil specified in the engine user and maintenance manual. We recommend only SAE 15/40 multigrade oil, which guarantees good engine lubrication at temperatures from -15°C to over 40°C (fig. 30).

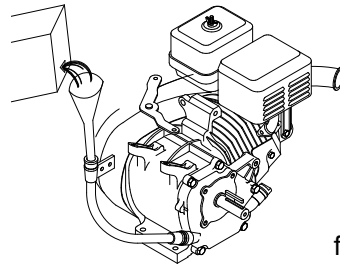

fig. 30

AIR FILTER OF THE ENGINE

NOTE: in addition to referring to the specific user and maintenance manual available on the manufacturer's website, below are some practical tips.

Periodically check the engine air filter, and replace it when necessary.

Check and if necessary wash the sponge (pre-filter) with water and soap or other household detergent; wring it out and leave it to dry.

“CHANGE OIL” ALARM

CODE

The CHANGE OIL error code tells the operator to change the combustion engine oil every 100 operating hours (only active on combustion engine versions). Pressing the display button once (fig. 31) shows the partial operating hour counter for the combustion engine.

This is a four-digit display: the first digit on the left (0-9 range) and the three remaining digits display the actual hours of work of the engine. When having reached 100 operating hours, the machine shows the “CHANGE OIL” message flashing on the display, telling the operator to change the engine oil (see the chapter “COMBUSTION ENGINE MAINTENANCE”). After having changed the engine oil, reset the hour counter as follows:

- press the display button twice to view the partial operating hour counter.
- press the display button again and hold it for at least 5 seconds (the machine partial operating hour counter will be reset). The first digit on the display increases by one unit, so that the operator will know how many times oil has been replaced.

NOTE: if the engine oil is not changed, every time the machine is switched on again, the operator will hear a sound emitted by the horn five times, and the “CHANGE OIL” message will flash on the display. The “CHANGE OIL” message can be cleared by pressing the display button.

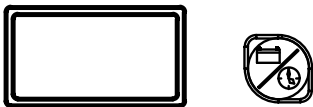

fig. 31

MAINTENANCE OF THE BATTERY VERSION

IMPORTANT: this operation must be performed with the machine switched off and the key removed..

All routine or special maintenance must be performed by competent personnel or at an authorised service centre.

NOTE: battery life depends on regular maintenance (check electrolyte level and density in leak-proof tubular batteries). If the machine is not used for a long time (for example, 4 to 6 weeks) the batteries will need to be recharged in order to ensure that the voltage never falls below the threshold of 20.5 V; in fact unused batteries suffer from the self-discharge phenomenon.

A : On receipt
B : Every 30 hours
C : Every 50 hours
D : Every 100 hours
E : Every 400 hours

CHECK	A	B	C	D	E
Battery liquid and voltage levels	<input type="checkbox"/>	<input type="checkbox"/> or every two weeks			
Check the brushes (or carbon brushes) on all of the electric motors and replace if worn					<input type="checkbox"/>
Tightness of the belts	<input type="checkbox"/>			<input type="checkbox"/>	
Brake adjustment	<input type="checkbox"/>			<input type="checkbox"/>	
Tightness of the nuts and screws					<input type="checkbox"/>
State of the side brush			<input type="checkbox"/>		
Panel filter cleaning			<input type="checkbox"/>		
Tightness of the bin, filter, flap gaskets	<input type="checkbox"/>		<input type="checkbox"/>		

COMBUSTION ENGINE VERSION MAINTENANCE

IMPORTANT: this operation must be performed with the machine switched off and the key removed..

All routine or special maintenance must be performed by competent personnel or at an authorised service centre.

For all maintenance on the combustion engine, see the instruction manual.

NOTE: battery life depends on regular maintenance (check electrolyte level and density in leak-proof tubular batteries). If the machine is not used for a long time (for example, 4 to 6 weeks) the batteries will need to be recharged in order to ensure that the voltage never falls below the threshold of 20.5 V; in fact unused batteries suffer from the self-discharge phenomenon.

A: On receipt
B: Twice a week
C: Every week
D: Every 20 hours
E: Every 50 hours
F: Every 100 hours
G: Every 150 hours
H: Every 300 hours
I: Every 400 hours

CHECK	A	B	C	D	E	F	G	H	I
Battery liquid and voltage levels	<input type="checkbox"/>		<input type="checkbox"/>						
Clean the engine air filter					<input type="checkbox"/>				
Panel filter cleaning					<input type="checkbox"/>				
Oil and engine	<input type="checkbox"/>		<input type="checkbox"/>						
Change engine oil, petrol version				1st time		<input type="checkbox"/>			
Change engine oil, diesel version					1st time	<input type="checkbox"/>			
Check the brushes (or carbon brushes) on all of the electric motors and replace if worn.									<input type="checkbox"/>
Tightness of the belts	<input type="checkbox"/>					<input type="checkbox"/>			
Brake adjustment	<input type="checkbox"/>					<input type="checkbox"/>			
Tightness of the nuts and screws									<input type="checkbox"/>
State of the side brush					<input type="checkbox"/>				
Tightness of the bin, filter, flap gaskets	<input type="checkbox"/>				<input type="checkbox"/>				

DISPLAY ALARMS

Error code	Machine behaviour	Description of the problem	Possible solution
PAUSE MOTOR	Drive stops	Drive motor overtemperature > 95°C. Alternator overtemperature > 150°C	If having driven up a slope this may can be normal, let the motor cool down for 20 minutes. Check that the cooling fan is working Check that the brake is not locked. Check that the front wheel turns freely.
PAUSE DRIVE	Drive stops	Electronic control circuit overtemperature > 85°C	If the air temperature is high, stop the machine for 20 minutes, then start again. If the problem remains, contact a service centre.
BRUSH CURRENT	The working functions are disabled	Excess current or centre brush blocked	Check free brush movement or for the presence of any impediments (ropes, plastic and so on)
CHANGE OIL	This is only shown if the machine has a combustion engine	It is activated after 99 operating hours	It warns the operator to change the engine oil (to reset it, press the display button for 5 seconds while the hour counter is displayed)
BATTERY RESERVE	This is simply a warning that the battery charge is getting low	It is shown when the battery voltage falls below 21.3V	No action needed, except to charge the battery
BATTERY DISCHARGED	The machine's functions are stopped, excluding drive	If the voltage read falls below 20.3V for 3 seconds consecutively	Charge the battery

BATTERY EXHAUSTED	The machine stops	If the voltage read falls below 18V for 3 seconds consecutively	Charge the battery
BRUSH WORN	The machine continues working	The brush is no longer able to apply pressure to the floor because it is worn	Replace the centre brush

DRIVE BOARD ALARMS

If drive is interrupted, the error code can be identified by means of the status LED. In the absence of malfunctions, the status LED is steadily on while the machine is in operation. If a malfunction is detected, the status LED provides two types of information, a slow flash (2 Hz) or a rapid flash (4 Hz) to indicate the severity of the malfunction.

Malfunctions with a slow flash are cancelled automatically once the malfunction has been repaired and the machine functions normally again. Malfunctions with a rapid flash ("*" in the table) are considered more serious. The machine must be turned off to reset operation after repairing the malfunction.

The indication of severity remains active for 10 seconds, after which the status LED flashes constantly showing a two digit malfunction code until the repairs have been carried out.

For example, error code "1,4" is displayed as follows:

□ □ □ □ □ example alarm code 1,4

	LED CODES	DESCRIPTION	SOLUTION
1,1	□ □	Drive motor output malfunction - Overcurrent error	Contact customer service
1,2	□ □ □	EEPROM malfunction, main contactor malfunction, malfunction of board components, incorrect drive motor voltage.	
1,3	□ □ □ □	NOT USED	
1,4	□ □ □ □ □	NOT USED	
2,1	□ □ □	Incorrect machine start up sequence (with key)	
2,2	□ □ □ □	Incorrect machine start up sequence (with key)	
2,3	□ □ □ □ □	Incorrect start up sequence for more than five seconds	
2,4	□ □ □ □ □ □	Malfunction of speed limiter potentiometer on control panel	
3,1	□ □ □ □	NOT USED	
3,2	□ □ □ □ □	NOT USED	
3,3	□ □ □ □ □ □	Accelerator pedal malfunction	
3,4	□ □ □ □ □ □ □	NOT USED	
4,1	□ □ □ □ □	Battery voltage too low (voltage < 21 V)	
4,2	□ □ □ □ □ □	Battery voltage too high (voltage > 48 V)	
4,3	□ □ □ □ □ □ □	Drive motor > 80°C thermal cutout tripped	
4,4	□ □ □ □ □ □ □ □	NOT USED	

USER MENU

Enter the menu by pressing and holding the display button for 5 seconds while the machine is on, but with no active function.

Pressing button P1 increases the value of the selected variable.

Pressing button P3 decreases the value of the selected variable.

Pressing the display button, the set data is saved and the next item is displayed.

Exit the menu by pressing and holding the display button for 5 seconds.

1. LANGUAGE, language setting parameter.
2. PROG.1, brush pressure P1 parameter. Default value 020.
3. PROG.2, brush pressure P2 parameter. Default value 040.
4. PROG.3, brush pressure P3 parameter. Default value 060.
5. POWER OFF, enables/disables the AUTO-POWER ON/OFF system. Default value YES.
6. RAISE BRUSH, enables/disables lifting of the centre brush in reverse. Default value YES.
7. FILTER SHAKE, enables/disables automatic activation of the filter shaker and the activation time. Default value 120".

TECHNICAL MENU

Enter the menu by pressing buttons P1 and P3 and turning the ignition key to "ON"; the display will show the first value, UP 1.x.

Press the Display button four times, select the type of battery installed (GEL or ACID) by pressing button P1 or P3.

To save the settings and exit the menu, press and hold the Display button until the display shows the software version installed.

To cancel the changes and exit the menu, switch the machine off by turning the ignition key to "OFF".

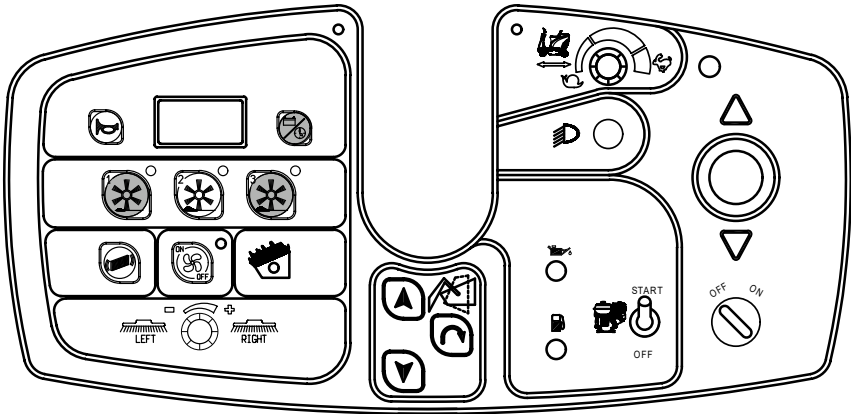

TROUBLESHOOTING

PROBLEM	CAUSE	REMEDY
The machine raises dust.	Filter clogged.	Shake the filter using the filter shaker and if necessary remove and carefully clean the filter
	Filter damaged.	Replace the filter
	Filter incorrectly fitted.	Fit the filter correctly in position
	Safety thermostat activated	Remove the heat source from the debris bin.
The machine leaves dirt on the ground.	The main brush has collected string or wire.	Remove the string and wire picked up.
	The flaps are damaged.	Replace the flaps
	Debris bin full.	Empty the debris bin
The main brush does not rotate.	Belt broken.	Contact customer service
	Fuse burned out.	Contact customer service
	Cable disconnected.	Check
	Reduction drive damaged.	Contact customer service
The side brushes do not rotate.	Cutout tripped.	Contact customer service
	Microswitch faulty.	Contact customer service
	Cable disconnected.	Check
The suction motor does not work.	Blown fuse.	Contact customer service
	Cable disconnected.	Check
	Motor damaged.	Contact customer service
	Safety thermostat activated	Remove the heat source from the debris bin.
The filter shaker motor does not work.	Blown fuse.	Contact customer service
	Cable disconnected.	Check
	Motor damaged.	Contact customer service
The machine won't start	Battery terminals disconnected	Check
	Batteries discharged	Recharge.
	Emergency stop button pressed	Reset.
	No fuel	Top up
	No engine oil	Top up
	Driver detection device faulty	Contact customer service
	Operator not correctly seated.	Sit correctly in the seat.
	Main fuse blown	Contact customer service
The batteries do not hold their charge.	No liquid	Top up.
	Loose terminal	Tighten.





IPC

IP Cleaning S.r.l.
Viale Treviso 63
30026 Summaga di Portogruaro
Venezia (Italy)
T: +39 0421 205511
F: +39 0421 204227
E: www.ipcworldwide.com
W: info@ipcworldwide.com

