

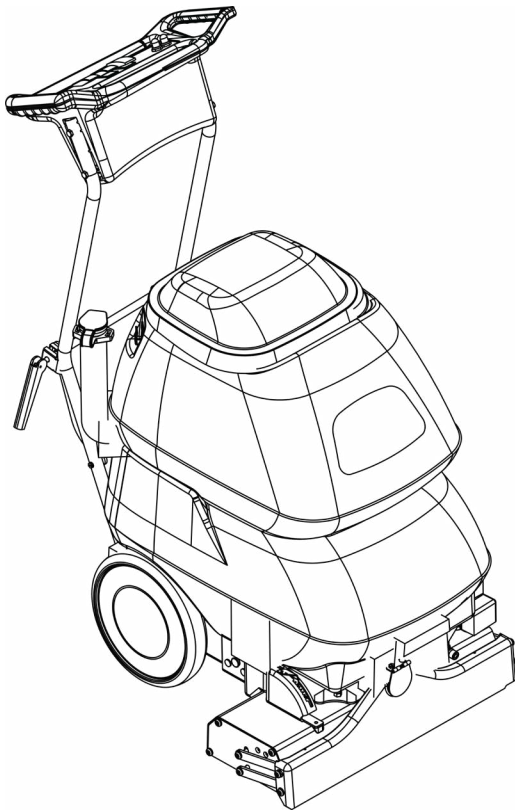

PACIFIC[®]
F L O O R C A R E

SCE-20

Self-Contained Extractor Parts & Operations Manual



Model: SCE-20

This operator's book has important information for the use and safe operation of this machine. Read this book carefully before starting the machine. Keep this book and tell all operators to read the book. If you do not follow the instructions, you can cause an injury or damage equipment, furniture or buildings.

For new books, please download your copy from our website www.pacificfloorcare.com or write to:

Pacific Floorcare
2259 S. Sheridan Drive
Muskegon, MI 49442-6252

Carefully inspect all components to ensure that there is no concealed freight damage. If such damage is discovered, file a "CONCEALED DAMAGE REPORT" immediately with the delivering carrier.

The contents of this manual are based on the latest product information available at the time of publication.

Pacific reserves the right to make changes or improvements without notice.



WARNING:

This product and accessories may contain a chemical known to the State of California to cause cancer and birth defects or other reproductive harm.

For more information about this regulation: www.P65Warnings.ca.gov

MACHINE DATA LOG/OVERVIEW

Model: _____

Date of Purchase: _____

Serial Number: _____

Sales Representative: _____

Address: _____

Phone Number: _____

TABLE OF CONTENTS

<i>Machine Data Log/Overview</i>	1
<i>Table of Contents</i>	2

HOW TO USE THIS MANUAL

<i>How to use this Manual</i>	1-1
-------------------------------------	-----

SAFETY

<i>Important Safety Instructions</i>	2-1
<i>Hazard Intensity Level</i>	2-3
<i>Grounding Instructions</i>	2-5

OPERATIONS

<i>Technical Specifications</i>	3-1
<i>Controls/Component Location</i>	3-2
<i>Filling Operation</i>	3-5
<i>Operations</i>	3-6
<i>Cleaning Procedure</i>	3-8
<i>Accessory Tool Usage</i>	3-10

MAINTENANCE

<i>Periodic Maintenance</i>	4-1
<i>Daily/ Regular Maintenance</i>	4-1
<i>Vacuum Motor Replacement</i>	4-2
<i>Solution Pump Replacement</i>	4-3
<i>Belt Replacement</i>	4-4
<i>Troubleshooting Chart</i>	4-5
<i>Suggested Spare Parts/Notes</i>	4-6

SPARE PARTS

<i>Frame</i>	5-1
<i>Brush</i>	5-3
<i>Pump</i>	5-5
<i>Vacuum Shoe</i>	5-7
<i>Control Panel</i>	5-9
<i>Solution Tank</i>	5-11
<i>Recovery Tank</i>	5-13
<i>Suggested Spare Parts</i>	5-17
<i>Wiring Diagram</i>	5-16

HOW TO USE THIS MANUAL

This manual contains the following sections:

- HOW TO USE THIS MANUAL
- SAFETY
- OPERATIONS
- MAINTENANCE
- PARTS LIST

The HOW TO USE THIS MANUAL section will tell you how to find important information for ordering correct repair parts.

Parts may be ordered from authorized dealers. When placing an order for parts, the machine model and machine serial number are important. Refer to the MACHINE DATA box which is filled out during the installation of your machine. The MACHINE DATA box is located on the inside of the front cover of this manual.

Model:	_____
Date of Purchase:	_____
Serial Number:	_____
Dealer:	_____
Address:	_____
Phone Number:	_____
Sales Representative:	_____

The model and serial number of your machine is on the bottom back-end of the machine.

The SAFETY section contains important information regarding hazard or unsafe practices of the machine. Levels of hazards is identified that could result in product or personal injury, or severe injury resulting in death.

The OPERATIONS section is to familiarize the operator with the operation and function of the machine.

The MAINTENANCE section contains preventive maintenance to keep the machine and its components in good working condition. They are listed in this general order:

- Periodic
- Daily/Regular

The PARTS LIST section contains assembled parts illustrations and corresponding parts list. The parts lists include a number of columns of information:

- **REF** – column refers to the reference number on the parts illustration.
- **PART NO.** – column lists the part number for the part.
- **PRV NO.** – reference number.
- **QTY** – column lists the quantity of the part used in that area of the machine.
- **DESCRIPTION** – column is a brief description of the part.
- **SERIAL NO. FROM** – column indicates the first machine the part number is applicable to. When the machine design has changed, this column will indicate serial number of applicable machine. The main illustration shows the most current design of the machine. The boxed illustrations show older designs. If column has an asterisk (*), call manufacturer for serial number.
- **NOTES** – column for information not noted by the other columns.

NOTE: If a service or option kit is installed on your machine, be sure to keep the KIT INSTRUCTIONS which came with the kit. It contains replacement parts numbers needed for ordering future parts.

NOTE: The number on the lower left corner of the front cover is the part number for this manual.

IMPORTANT SAFETY INSTRUCTIONS

When using an electrical appliance, basic precaution must always be followed, including the following:

READ ALL INSTRUCTIONS BEFORE USING THIS MACHINE.

This machine is for commercial use.



To reduce the risk of fire, electric shock, or injury:

Connect to a **properly grounded outlet**. See Grounding Instructions.

Do not leave the machine unattended. Unplug machine from outlet when not in use and before maintenance or service.

Use only indoors. Do not use outdoors or expose to rain or freezing temperatures.

Do not allow machine to be used as a toy. **Close attention** is necessary when used by or near children.

Use only as described in this manual. Use only manufacturer's recommended components and attachments.

Do not use damaged electrical cord or plug. Follow all instructions in this manual concerning grounding the machine. If the machine is **not working properly**, has been dropped, damaged, left outdoors, or dropped into water, return it to an authorized service center.

Do not pull or carry machine by electrical cord, use as a handle, close a door on cord, or pull cord around sharp edges or corners.

Do not run machine over cord. **Keep** cord away from heated surfaces.

Do not unplug machine by pulling on cord. To unplug, grasp the electrical plug, not the electrical cord.

Do not handle the electrical plug or machine with wet hands.

Do not operate the machine with any openings blocked. Keep openings free of debris that may reduce airflow.

This machine is intended for cleaning carpet only.

Do not vacuum anything that is burning or smoking, such as cigarettes, matches, or hot ashes.

This machine is not suitable for picking up health endangering dust.

Turn off all controls before unplugging.

Do not operate this machine near flammable fluids, dust or vapors.

Maintenance and repairs must be done by qualified personnel.

If foam or liquid comes out of machine, switch off immediately.

SAVE THESE INSTRUCTIONS

SAFETY

IMPORTANTES MESURES DE SÉCURITÉ

L'utilisation d'un appareil électrique demande certaines précautions:

LIRE TOUTES LES INSTRUCTIONS AVANT DE FAIRE FONCTIONNER (CET APPAREIL).



Pour réduire les risques d'incendie, de choc électrique ou de blessure:

Cet appareil ne doit être connecter qu a des prises ayant une sortie de terre.

Ne pas laisser l'appareil sans surveillance lorsqu'il est branché. Débrancher lorsque l'appareil n'est pas utilisé et avant l'entretien.

Pour reduire les risques de choc electrique, ne pas utiliser à l'exterieur et ne pas aspirer de matières humides.

Ne pas permettre aux enfants de jouer avec l'appareil. Une attention particulière est nécessaire lorsque l'appareil est utilisé par des enfants ou à proximité de ces derniers.

Utiliser cet appareil conformément aux instructions du présent manuel uniquement. N'utiliser que les composants et les accessoires conseillés par le fabricant.

Ne pas utiliser si le cordon ou la fiche est endommagé. Retourner l'appareil à un atelier de réparation s'il ne fonctionne pas bien, s'il est tombé ou s'il a été endommagé, oublié à l'extérieur ou immergé.

Ne pas tirer soulever ou traîner l'appareil par le cordon. Ne pas utiliser le cordon comme une poignée, le coincer dans l'embrasure d'une porte ou l'appuyer contre des arêtes vives ou des coins. Ne pas faire rouler l'appareil sur le cordon.

Garder le cordon à l'écart des surfaces chaudes.

Ne pas débrancher en tirant sur le cordon. Tirer plutôt la fiche.

Ne pas toucher la fiche ou l'appareil lorsque vos mains sont humides.

N'insérer aucun objet dans les ouvertures. Ne pas utiliser l'appareil lorsqu'une ouverture est bloquée. S'assure que de la poussière, de la peluche, des cheveux ou d'autres matières ne réduisent pas le débit d'air.

Cette machine est destinée pour nettoyer le tapis seulement.

Ne pas aspirer de matières en combustion ou qui dégagent de la fumée, comme des cigarettes, des allumettes ou des cendres chaudes.

Cette machine **n'est pas** adaptée au ramassage de poussières dangereuses.

Mettre toutes les commandes à la position ARRÊT avant de débrancher l'appareil.

Ne pas aspirer des liquides inflammables ou combustibles, comme de l'essence, et ne pas faire fonctionner dans des endroits où peuvent se trouver de tels liquides.

L'entretien et les réparations de la machine **doivent être effectuées** par un personnel qualifié.

Si de la mousse ou du liquide sort de la machine, **la mettre hors tension immédiatement.**

CONSERVER CES INSTRUCTIONS

HAZARD INTENSITY LEVEL

The following symbols are used throughout this guide as indicated in their descriptions:

HAZARD INTENSITY LEVEL

There are three levels of hazard intensity identified by signal words -**WARNING** and **CAUTION** and **FOR SAFETY**. The level of hazard intensity is determined by the following definitions:



WARNING - Hazards or unsafe practices which COULD result in severe personal injury or death.



CAUTION - Hazards or unsafe practices which could result in minor personal injury or product or property damage.

FOR SAFETY: To identify actions which must be followed for safe operation of equipment.

Report machine damage or faulty operation immediately. Do not use the machine if it is not in proper operating condition. Following is information that signals some potentially dangerous conditions to the operator or the equipment. Read this information carefully. Know when these conditions can exist. Locate all safety devices on the machine. Please take the necessary steps to train the machine operating personnel.

FOR SAFETY:

DO NOT OPERATE MACHINE:

Unless Trained and Authorized.

Unless Operation Guide is Read and understood.

In Flammable or Explosive areas.

In areas with possible falling objects.

WHEN SERVICING MACHINE:

Avoid moving parts. Do not wear loose clothing; jackets, shirts, or sleeves when working on the machine. Use manufacturer approved replacement parts.

DEGRÉS DE RISQUES EN CAS DE DANGER

Les symboles ci-dessous sont utilisés à travers ce manuel comme illustré dans leurs descriptions :

DEGRÉS DE RISQUES EN CAS DE DANGER

Il existe trois degrés de risques identifiés par les termes signalétiques –**AVERTISSEMENT** et **ATTENTION** et **POUR VOTRE SÉCURITÉ**. Le degré de risque est défini de la manière suivante :

AVERTISSEMENT:

AVERTISSEMENT - Dangers ou méthodes dangereuses qui **POURRAIENT** provoquer de graves blessures ou entraîner la mort.

ATTENTION:

ATTENTION - Dangers ou méthodes dangereuses qui pourraient provoquer des blessures légères ou une détérioration du produit ou des biens immobiliers.

POUR VOTRE SÉCURITÉ : ce signe permet d'identifier les mesures de précaution à prendre pour assurer un bon fonctionnement du matériel.

Rendre compte immédiatement d'une défaillance ou d'une détérioration de la machine. Ne pas utiliser la machine si celle-ci ne fonctionne pas correctement. Lire soigneusement les informations ci-dessous signalant certains dangers potentiels pour l'opérateur de la machine. L'opérateur doit être absolument au courant de ces dangers potentiels. Localiser tous les dispositifs de sécurité sur la machine. Il est conseillé de prendre les mesures nécessaires pour former le personnel opérateur.

POUR VOTRE SÉCURITÉ :

NE PAS MANOEUVRER LA MACHINE :

Lorsqu'on n'est pas expérimenté ou qualifié.

Lorsque le guide d'utilisation n'est pas été lu ou compris.

Dans des zones inflammables ou explosives.

Dans des zones où des objets peuvent tomber.

LORS DE L'ENTRETIEN DE LA MACHINE :

Éviter les parties amovibles. Ne pas porter de vêtements amples, tels que des vestes, des chemises ou des vêtements avec manches lors de l'utilisation de la machine. Utiliser les pièces détachées Windsor homologuées.

GROUNDING INSTRUCTIONS

ELECTRICAL:

In the USA, this machine operates on a standard 15 amp 115V, 60 Hz, A.C. power circuit. The amp, hertz, and voltage are listed on the data label found on each machine. Using voltages above or below those indicated on the data label will cause serious damage to the motors.

EXTENSION CORDS:

If an extension cord is used, the wire size must be at least one size larger than the power cord on the machine, and must be limited to 50 feet (15.5m) in length.

GROUNDING INSTRUCTIONS:

This appliance must be grounded. If it should malfunction or break down, grounding provides a path of least resistance for electric current to reduce the risk of electric shock. This appliance is equipped with a cord having an equipment-grounding conductor and grounding plug. The plug must be inserted into an appropriate outlet that is properly installed and grounded in accordance with all local codes and ordinances.

This appliance is for use on a nominal 120-volt circuit, and has a grounded plug that looks like the plug in "Fig. A". A temporary adaptor that looks like the adaptor in "Fig. C" may be used to connect this plug to a 2-pole receptacle as shown in "Fig. B", if a properly grounded outlet is not available. The temporary adaptor should be used only until a properly grounded outlet (Fig. A) can be installed by a qualified electrician. The green colored rigid ear, lug, or wire extending from the adaptor must be connected to a permanent ground such as a properly grounded outlet box cover. Whenever the adaptor is used, it must be held in place by a metal screw.

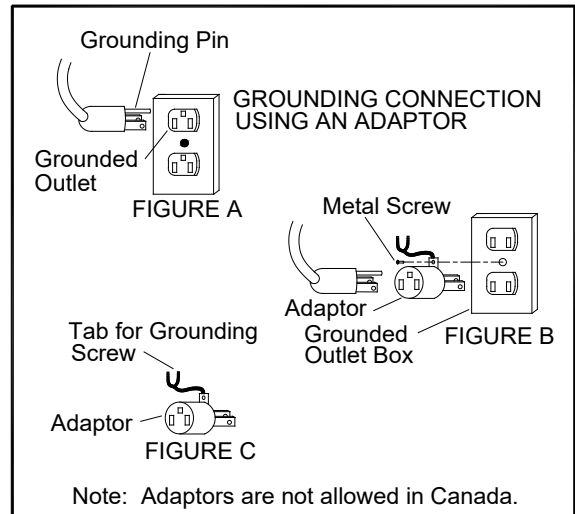

⚠ WARNING:

Improper connection of the equipment-grounding conductor can result in a risk of electric shock. Check with a qualified electrician or service person if you are in doubt as to whether the outlet is properly grounded. Do not modify the plug provided with the appliance - if it will not fit the outlet; have a proper outlet installed by a qualified electrician.

⚠ AVERTISSEMENT:

Le raccordement incorrect du conducteur de terre d'équipement peut entraîner des risques d'électrocution. Vérifiez auprès d'un électricien qualifié ou d'un responsable de l'entretien si vous avez quelque doute que ce soit quant au raccordement à la terre de votre prise murale. Ne modifiez pas la fiche fournie avec l'appareil : si elle ne correspond pas à la prise murale, faites installer une prise adéquate par un électricien qualifié. Utilisez-le uniquement sur des réceptacles protégés GFCI.

TECHNICAL SPECIFICATIONS

POWER TYPE

ELECTRICAL: 115 V, 15 A, 60 HZ

ELECTRIC VACUUM MOTOR: (1) –3 stage, 1 hp, 99 cfm
(2.80 cubic meters/min.) Waterlift –117" (297cm)

BRUSH: (1) 18" (45.7 cm.)

SOLUTION PUMP: 100 PSI, diaphragm style, internal
bypass

SOLUTION CAPACITY: 9 gallons (34 ltr)

RECOVERY CAPACITY: 10 gallons (37.8 ltr)

BRUSH SPEED: 1000 rpm

GENERAL DIMENSIONS/WEIGHT

Vacuum shoe: 20" (51 cm) cast aluminum
with spring loaded down pressure

WHEELS: (2) 10" dia. (25 cm) wheels by 2"

WEIGHT: 94 lbs. (43 kg)

LENGTH: 33" (84 cm)

HEIGHT: 43" (110 cm)

WIDTH: 21" (53 cm)

SOLUTION SPRAY: 2 quick change jets.

POWER CABLE: 50' (12.7 m) (14 gauge)

CONTROLS/COMPONENT LOCATIONS

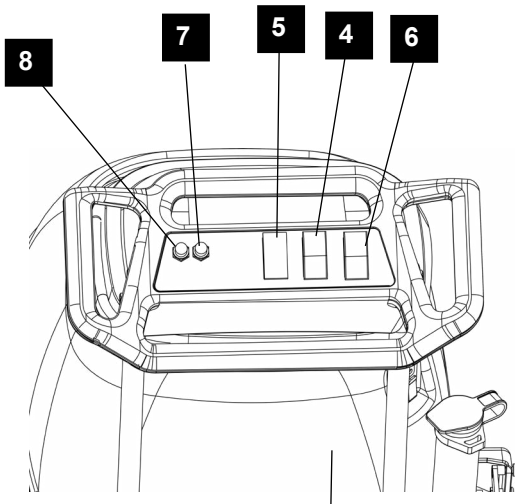

1. **Main Handle.** Used to pull and maneuver machine.
2. **Handle Adjustment.** Used to adjust height of handle.
3. **Electrical Cord.**
4. **Brush Motor Switch.** Turns on brush motor.
5. **Solution Switch.** Turns on pump. Continuous position (bottom) activates electro-valve to dispense solution to floor through jets. Intermittent position (up) requires operator to depress 1 of 3 trigger switches to dispense solution. Center position is off.
6. **Vacuum Motor Switch.** Turns on vacuum motor.
7. **Brush Motor Circuit Breaker.** 6 amp. Breaker protecting brush motor.
8. **Vacuum Motor Circuit Breaker.** 15 amp. Breaker protecting vacuum motor.
9. **Recovery Dump Hose.** Facilitates draining dirty cleaning solution.
10. **Solution Dump Hose.** Facilitates draining excess cleaning solution from solution tank.

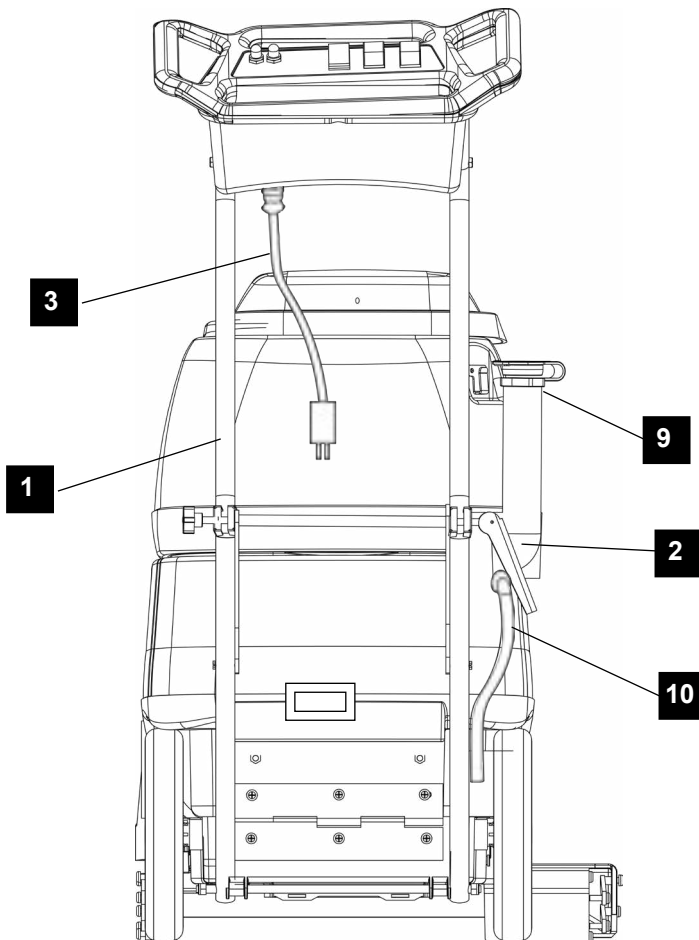

CONTROLS/COMPONENT LOCATIONS

1. **Solution Accessory Tool Hookup.** Used for various auxiliary cleaning tools.
2. **Vacuum Hose Door.** Used to connect various auxiliary 1 ½ inch cleaning tool vacuum hoses.
3. **Brush Height Adjustment.** Used to regulate brush height from storage position to various carpet heights.
4. **Recovery Tank.** Used to collect dirty cleaning solution.
5. **Solution Tank.** Used to hold cleaning solution.
6. **Recovery Tank Dome.**
7. **Vacuum Shoe.**
8. **Brush Housing.**
9. **Front Lifting Handle.**
10. **Cleaning Solution Filter.**
11. **Solution Tank Fill Hose.**

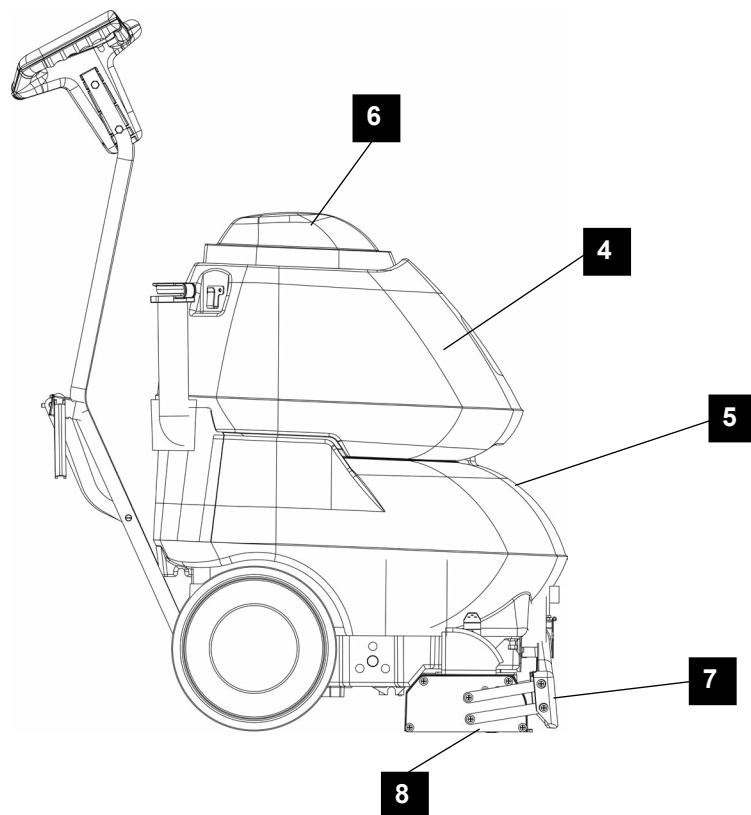
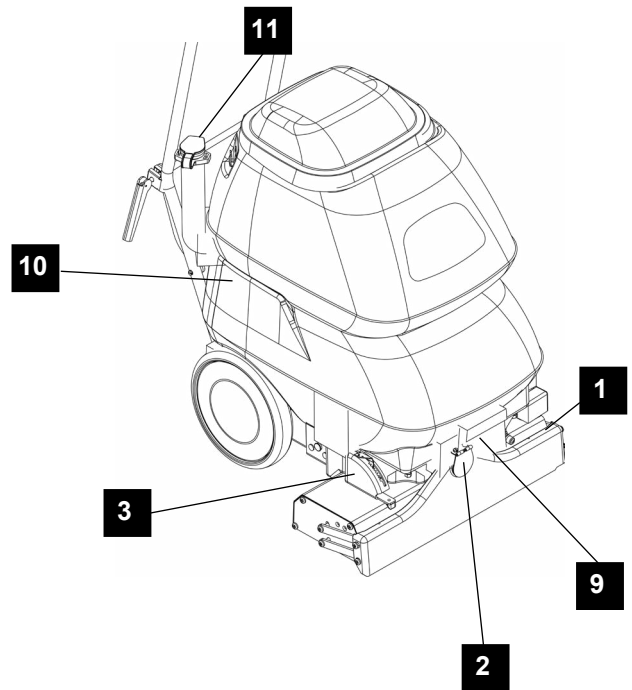

CONTROLS/COMPONENT LOCATIONS

1. Solution Intake Cover.
2. Vacuum Intake Cover.
3. Float Shut-Off.
4. Clean-Out Opening.
5. Pour Spout.
6. Lift Handle.

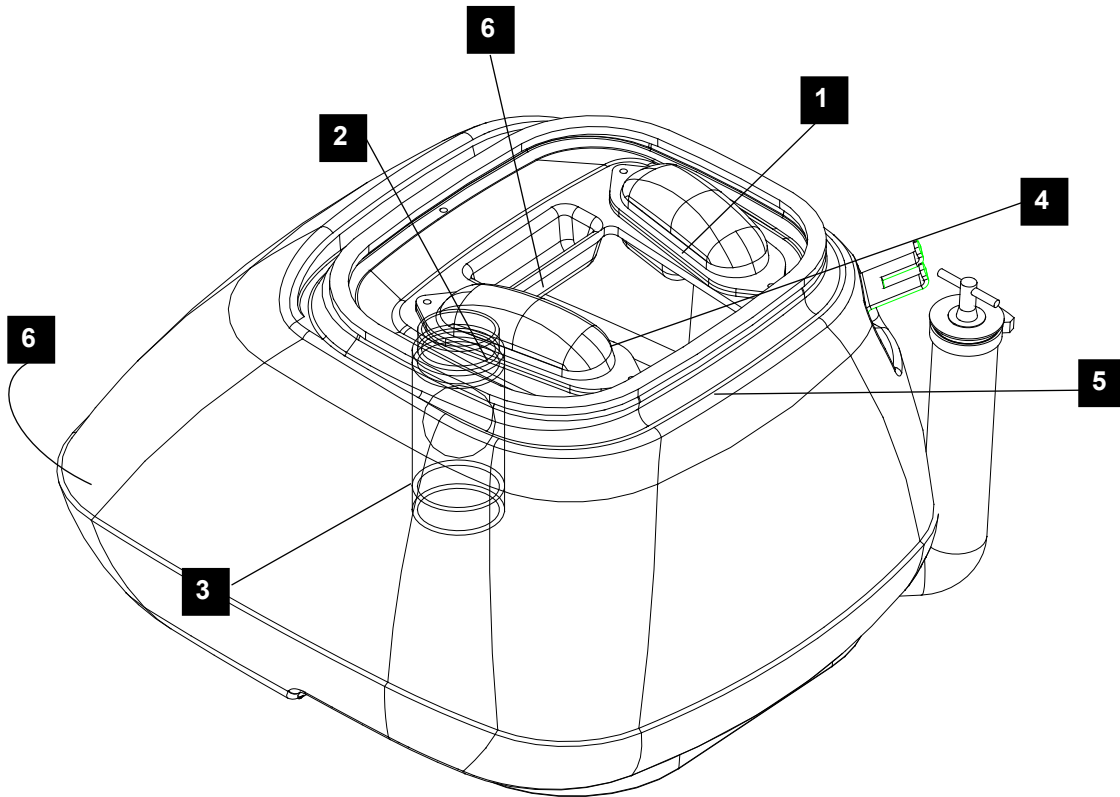

FILLING OPERATIONS

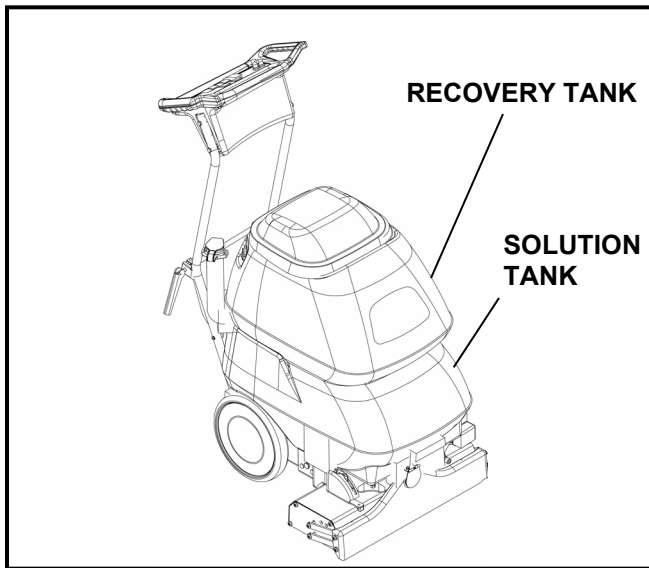

STEP 1

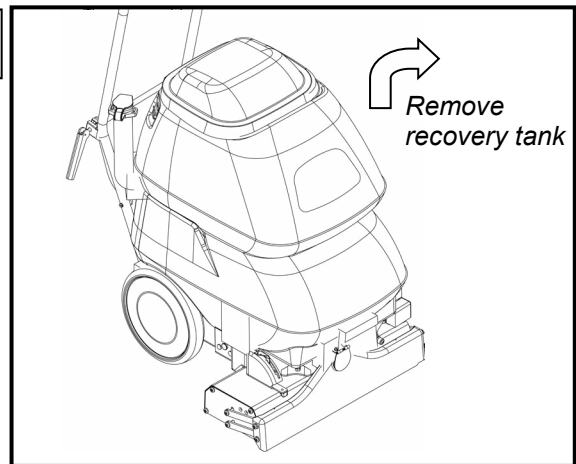

STEP 2

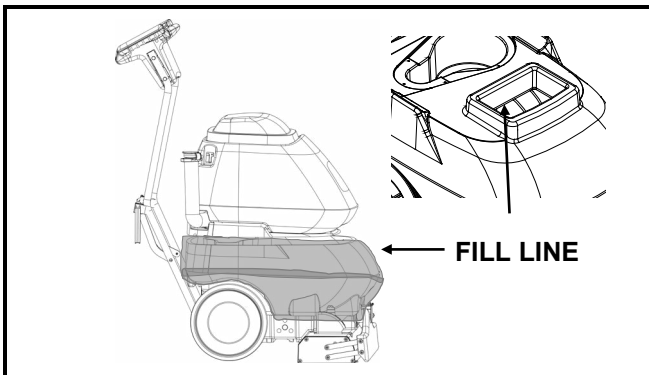
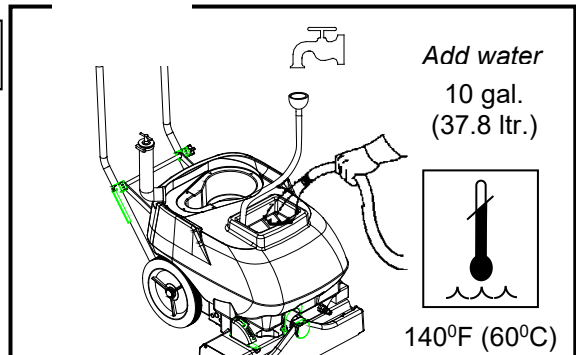

STEP 3

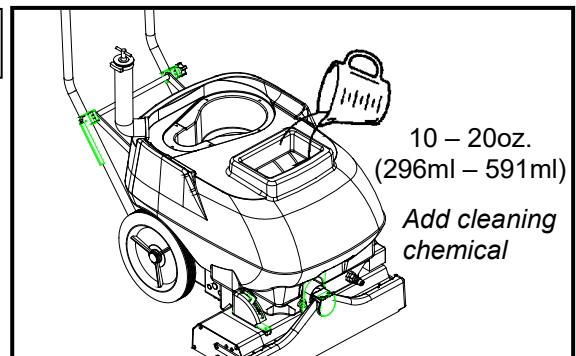

STEP 4

FILLING THE SOLUTION TANK

NOTE: Use clean bucket of water to fill solution tank

Do not put defoamer, solvents, spotter or prepray chemicals in the solution tank.

Do not allow water to spill into vacuum motor inlet. Dry spillage from top of solution tank before replacing recovery tank.

CHEMICALS

Suitable Chemicals

Alkalis
Detergents
Hydroxids
Soaps
Vinegar

Non-Compatible Chemicals

Aldehydes
Aromatic Hydrocarbons
SP Butyls
Carbon Tetrachloride
Clorox*
Chlorinated Bleaches
Chlorinated Hydrocarbons
Lysol*
Methyl Ethel Ketone (MEK)
Perchorethylene (perc)
Phenolics
Trichlorethylene
D-Limonene

* Product Trademark Names

OPERATIONS

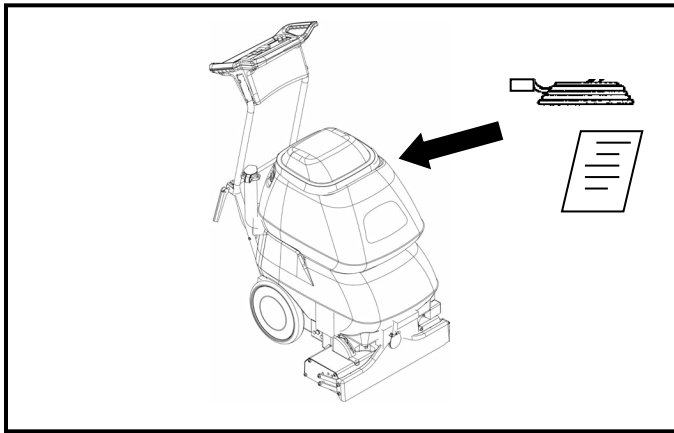

STEP 1 Remove electrical cord and literature from recovery tank. Fill solution tank (see filling instructions page 3-5).

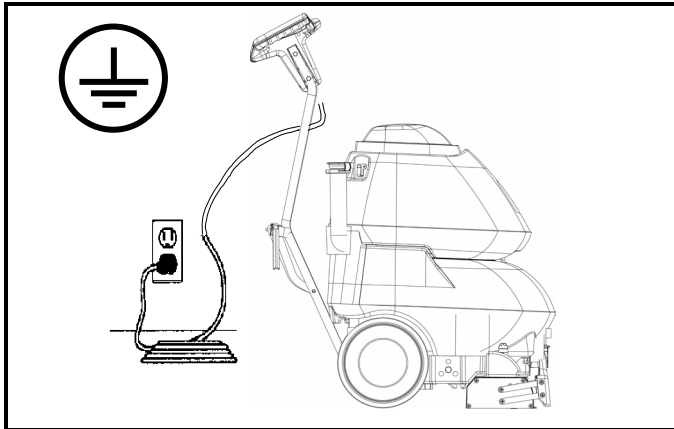

STEP 2 Plug cord into grounded outlet. *Note: Be sure dome is seated on recovery tank, and float shut-off is installed correctly.*

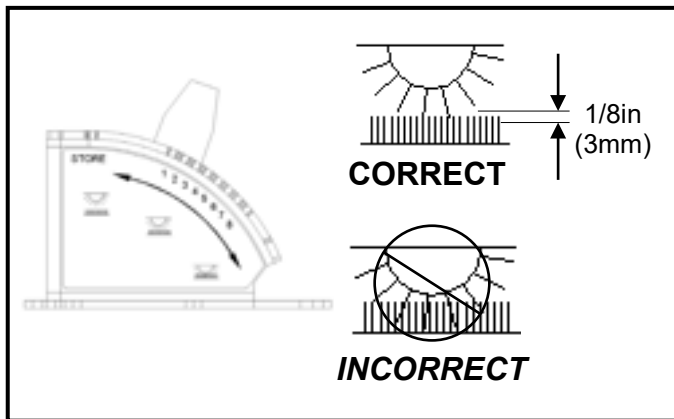

STEP 3 Adjust brush to proper setting. *Note: For good operation the brush must skim the carpet. If circuit breaker trips raise brush to prevent damage to motor or carpet.*

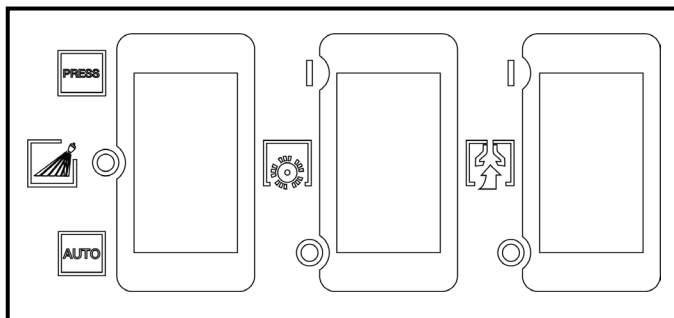

STEP 4 Turn on brush and vacuum motor switches ("ON"="I"). Turn on solution switch for continuous spray or set switch to intermittent to allow use of trigger switches.

OPERATIONS

Adjust handle to comfortable operating position. Tip machine back by main handle to move to starting point.

STEP
5

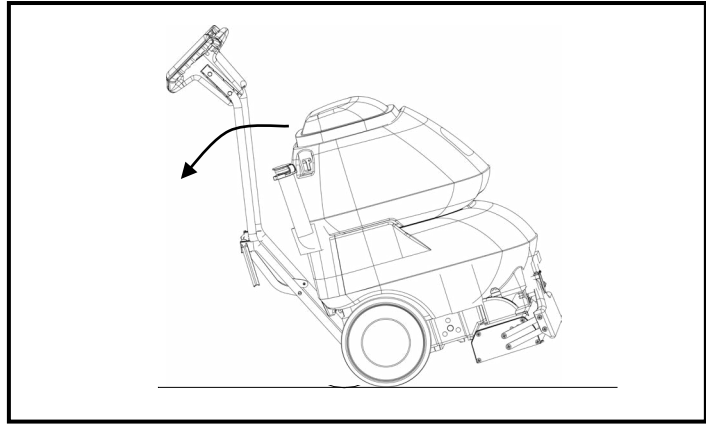

Lower machine to floor.

STEP
6

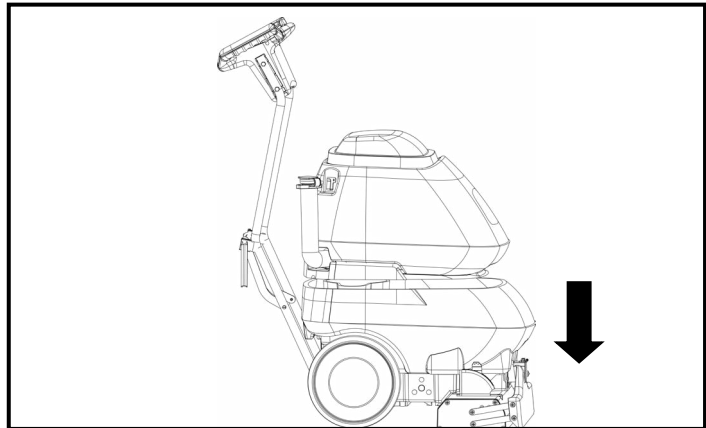

Select continuous setting to start solution spray or select intermittent setting to enable use of trigger switches to start solution spray.

The intermittent setting requires the operator to hold any one of the three trigger switches in the "on" position with the fingers, and is typically used in small areas where short cleaning passes are made.

The continuous setting allows the operator to set the switch in the "on" position with one touch, and is typically used in large

STEP
7

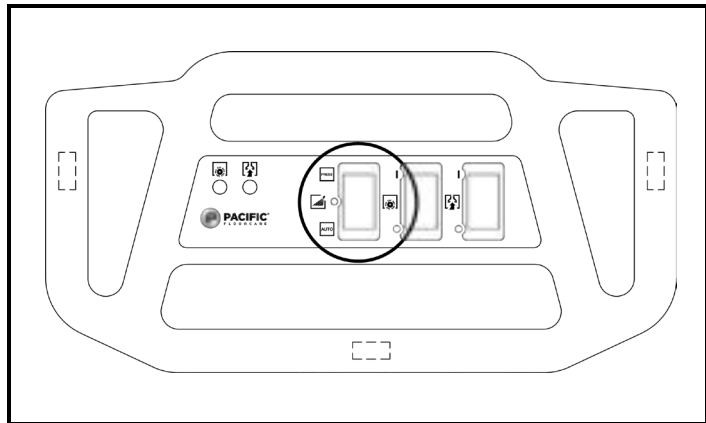

CLEANING PROCEDURE

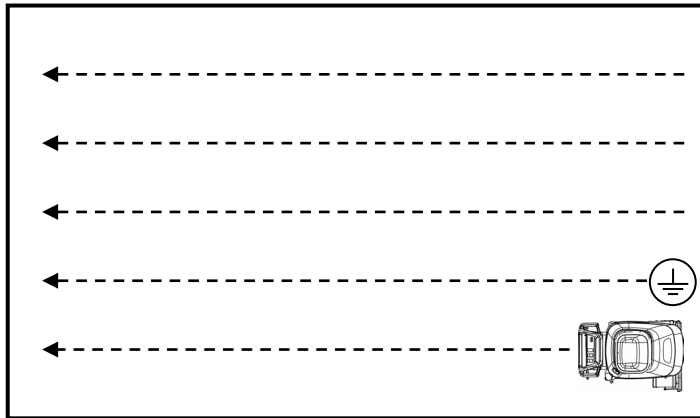

STEP 1 Start at wall closest to power outlet. Pull straight back without pushing down on handle.

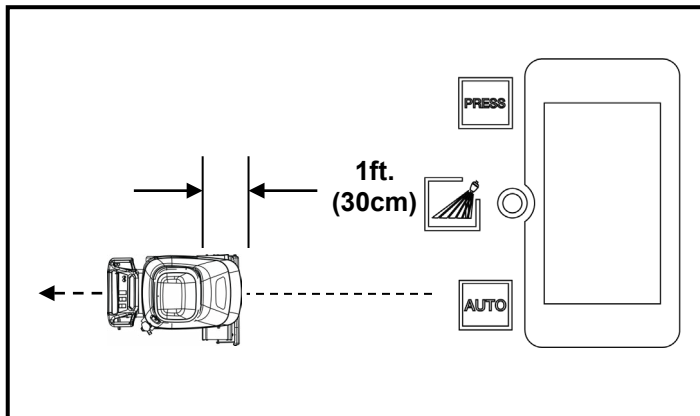

STEP 2 Release intermittent setting or turn off continuous setting on brush/spray switch approximately 1 foot before ending cleaning pass.

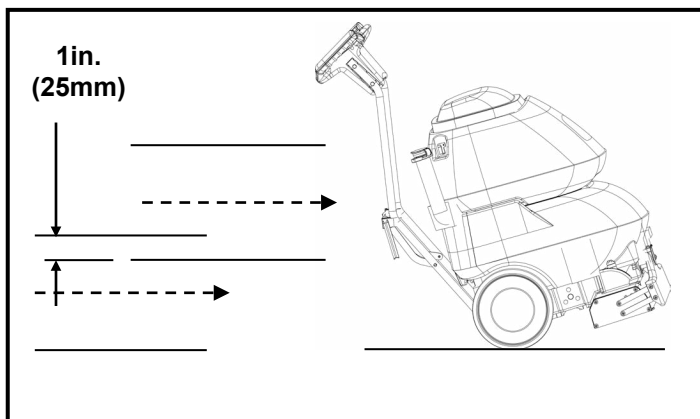

STEP 3 Push down on handle to raise vacuum shoe and brush before moving to the next cleaning pass. Overlap brush contact area approximately 1inch.

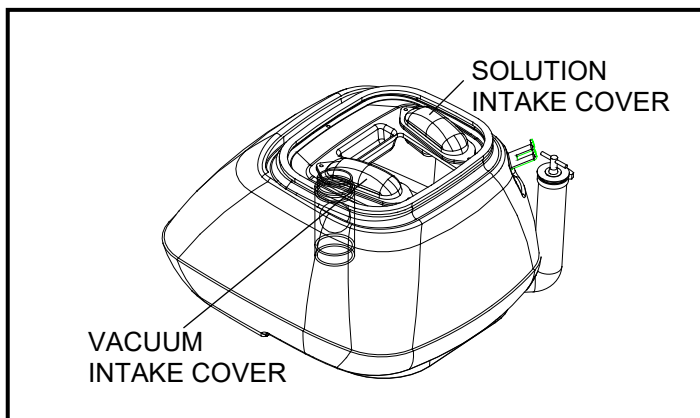

STEP 4 During operation, observe the following: The machine is equipped with clear internal covers to facilitate operator viewing of dirty solution and vacuum air flow. During operation, observe the vacuum intake cover. Large amounts of water or foam entering the vacuum system can damage the vacuum motor. If you notice either condition, **shut down the machine immediately**. Empty recovery tank and/or add defoamer to recovery tank.

CLEANING PROCEDURE

Use right side of machine for cleaning against walls.

STEP
5

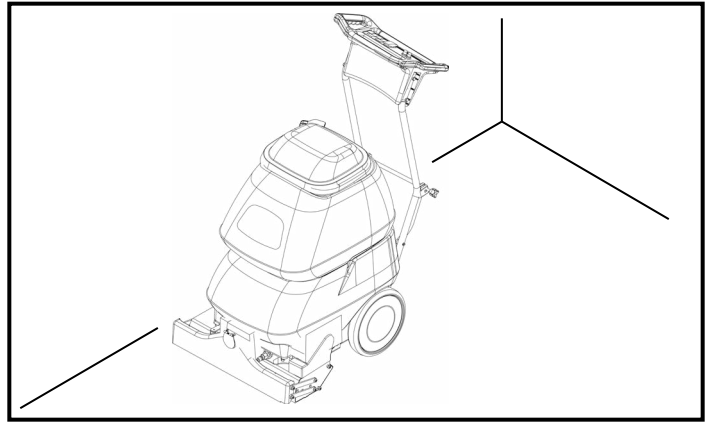

After cleaning, turn off all controls, return brush to storage position and carefully unplug machine.

STEP
6

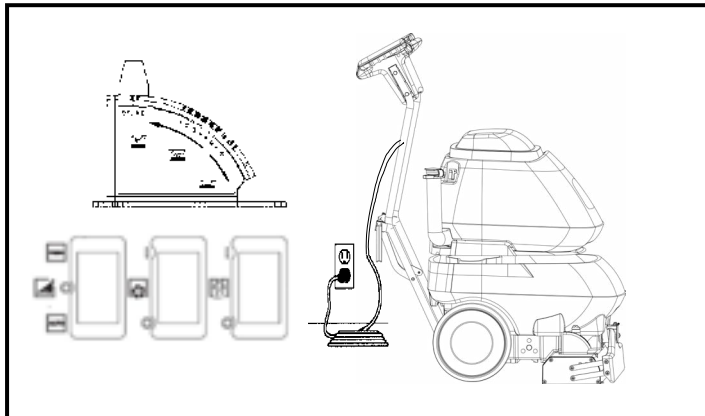

To speed drying, use a AB84 fan.

STEP
7

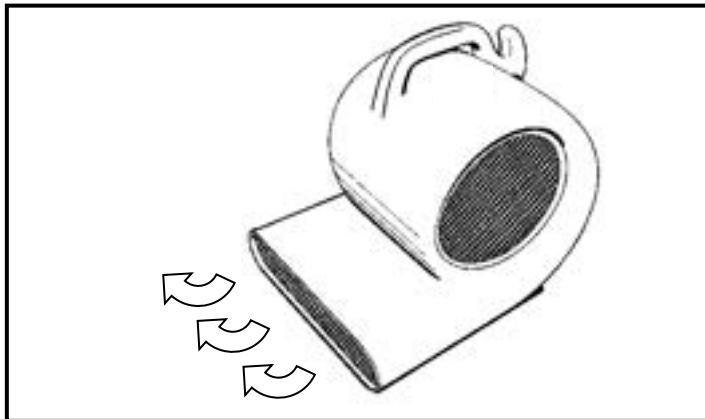

Empty recovery tank by releasing dump hose. Use a hose with cold water to clean out the recovery tank. Also drain solution tank after each use.

STEP
8

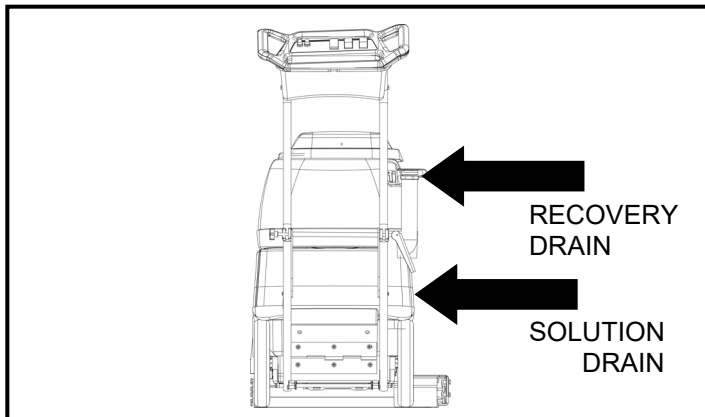

ACCESSORY TOOL USAGE

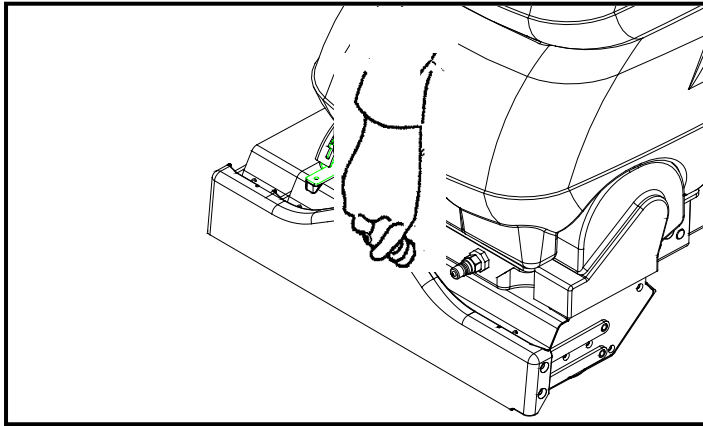

STEP
1

Pull back collar and insert over machine mounted fitting, then release collar to lock into place.

Only for acceptable accessory tools.

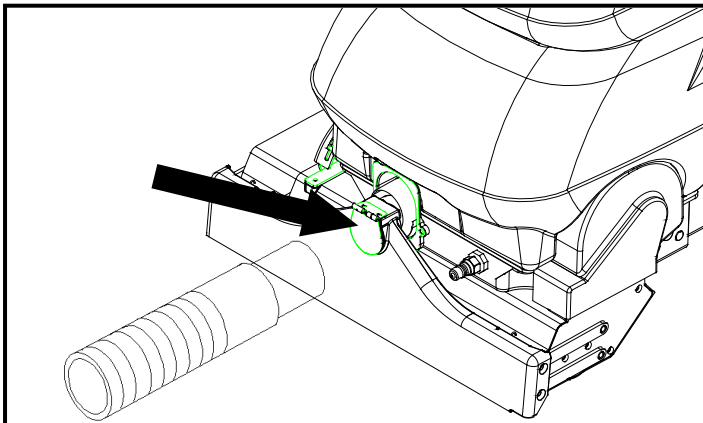

STEP
2

Lift door on front of vacuum shoe and insert 1 ½ inch hose cuff into hole.

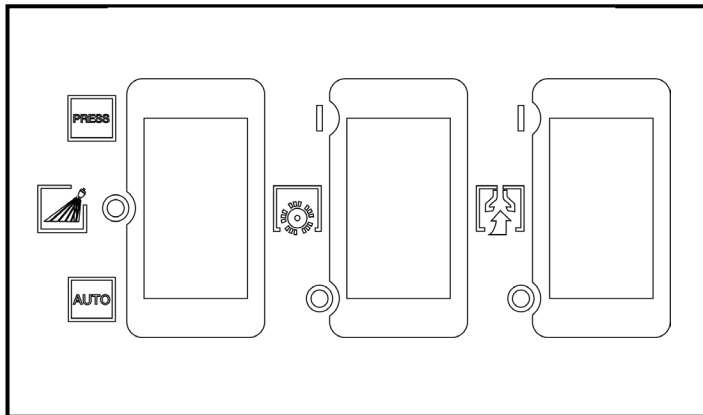

STEP
3

Turn on vacuum motor switch and set solution switch to intermittent position. NOTE: Be sure brush switch is in off position and brush is in storage position.

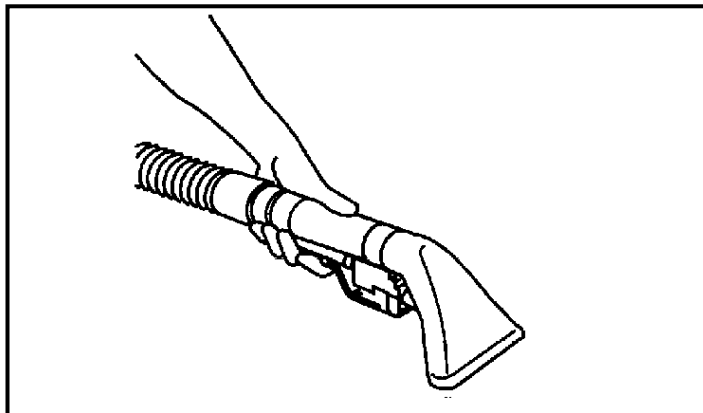

STEP
4

Squeeze handle on accessory tool to begin cleaning.

MAINTENANCE

PERIODIC MAINTENANCE

Twice a month, flush a white vinegar solution (One quart vinegar to two gallons of water) or anti-browning solution (mixed as directed) through the extractor. This will prevent build-up of alkaline residue in the system. If spray jets become clogged, remove the spray tips, wash them thoroughly, and blow-dry.

NOTE: Do not use pins, wire, etc. to clean nozzles as this could destroy spray pattern.

Periodically inspect all hoses, electrical cables and connections on your machine. Frayed or cracked hoses should be repaired or replaced to eliminate vacuum or solution pressure loss. If the cable insulation is broken or frayed, repair or replace it immediately. Don't take chances with electrical fire or shock.

DAILY / REGULAR MAINTENANCE

Before making any adjustments or repairs to the machine, disconnect the power cord from electrical source.

1. Empty unused cleaning solution from the solution tank.
2. Inspect and clean filter screen in solution tank.
3. Flush pumping system with 4 or 7 liters of clean, hot water.
4. After each use, rinse tank with fresh water. Periodically inspect the recovery tank and decontaminate if necessary, using a Hospital Grade Virucide or a 1-10 bleach to water solution. Waste water should be disposed of properly.
5. Check for and remove any lint or debris around vac shoe.
6. Check spray jets for full spray pattern.
7. Remove lint and dirt build-up from brush and housing.
NOTE: Brush removal.
 - A. To remove brush, grab and pull brush out from end opposite drive belt (operator's right). Remove other end from brush driver.
 - B. To install brush, line up slots in brush core with pin in driver on drive belt side (operator's left) and push brush onto driver. Then snap bearing end (opposite end) of brush into retaining clip.
8. Check cooling air screen (located on frame behind left wheel) for lint or debris.
9. Check float and shut-off screen and clean as necessary.

NOTE: Always store machine with brush in "Store" position.

⚠ WARNING:

Only qualified maintenance personnel are to perform the following repairs.

⚠ AVERTISSEMENT:

Seul le personnel d'entretien qualifié peut effectuer des réparations.

1. Turn off all switches and unplug machine.
2. Remove recovery tank.
3. Remove the (2) screws that fasten the solution tank to the frame, and tilt tank back to expose the inside of the frame.
4. Locate the vacuum motor wires and disconnect at the connector. Close the solution tank.
5. Remove the (6) screws holding the vacuum motor cover 86003080 (PRV NO. 27809) to the solution tank.
6. Remove the vacuum motor.
7. Reverse process to install vacuum motor.

WARNING: The green ground wire must be attached for safe operation. See wiring diagram.

AVERTISSEMENT: Le fil à la terre vert doit être attaché pour un fonctionnement en toute sécurité. voir le schéma de câblage.

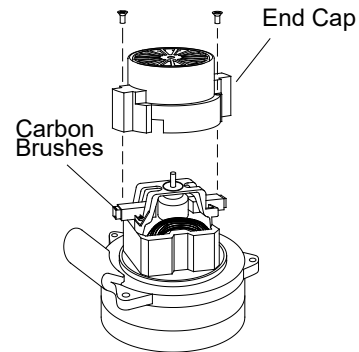

If armature commutator is grooved, extremely pitted or not concentric, the motor will need to be replaced or sent to a qualified service center.

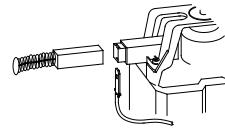

Important:

These brushes wear quicker as the length shortens due to increased heat. Spring inside brush housing will damage motor if brushes are allowed to wear away completely.

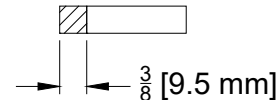

Periodically check the length of the carbon brushes. Replace both carbon brushes when either is less than 3/8" (9.5mm) long.

MAINTENANCE

⚠ WARNING:

Only qualified maintenance personnel are to perform the following repairs.

⚠ AVERTISSEMENT:

Seul le personnel d'entretien qualifié peut effectuer des réparations.

SOLUTION PUMP REPLACEMENT

1. Turn off all switches and unplug the machine.
2. Remove recovery tank.
3. Remove the (2) screws that fasten the solution tank to the frame, and tilt tank back to expose the inside of the frame.
4. Remove solution hoses from fittings in pump.
5. Remove the (2) screws that fasten the pump to the frame.
6. Reverse process to install pump.

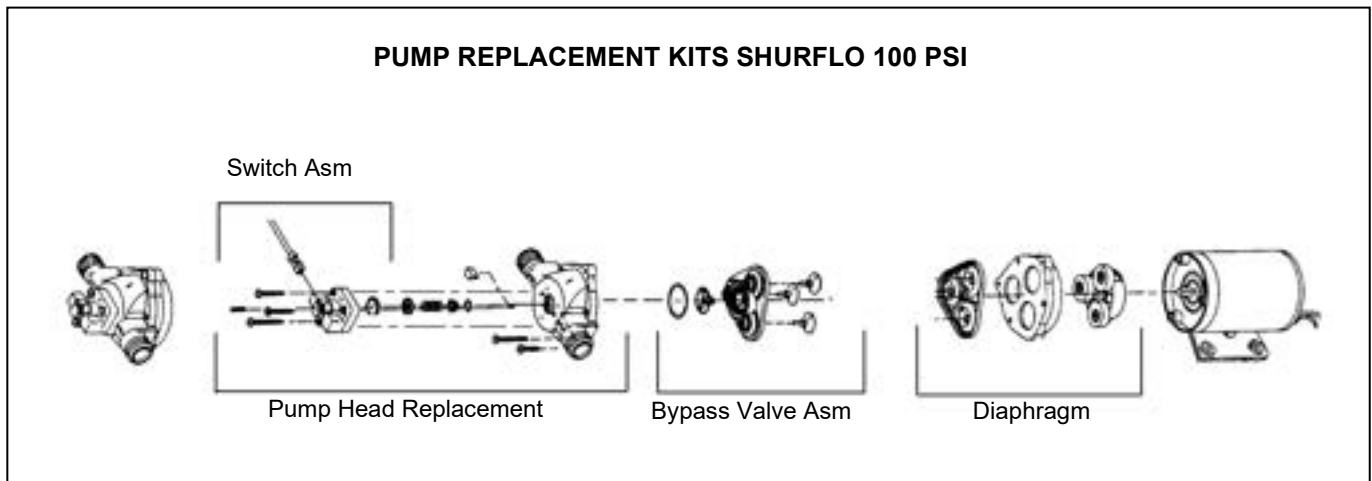

⚠ WARNING:

Only qualified maintenance personnel are to perform the following repairs.

⚠ AVERTISSEMENT:

Seul le personnel d'entretien qualifié peut effectuer des réparations.

BELT REPLACEMENT

1. Turn off all switches and unplug machine.
2. Remove recovery tank and brush.
3. Remove the (2) screws that fasten the solution tank to the frame, and tilt tank back to expose the inside of the frame.
4. Loosen the (4) screws that hold the brush motor in place and slide motor forward to release tension in belt.
5. Remove the (2) screws that fasten the vacuum shoe links (260014) to the brush housing.
6. Remove the (3) screws that fasten the side plate 260101-260106 to the brush housing to remove belt. *NOTE: All components associated with driving the brush will come out with the side plate.*
7. Reverse process to install belt.

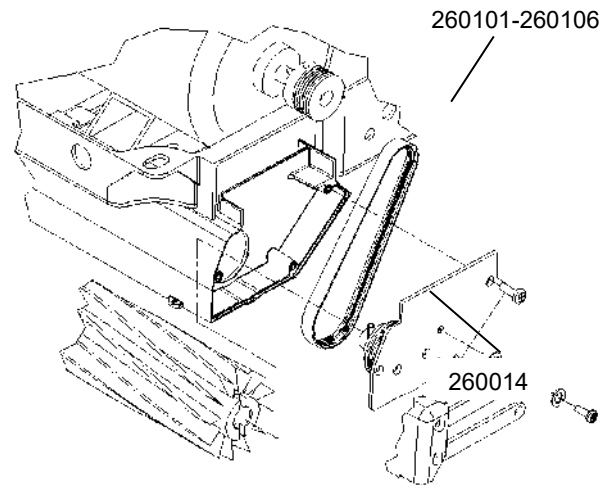

MAINTENANCE

Troubleshooting Chart

PROBLEM	CAUSE	SOLUTION
No Power, Nothing Runs	Is the cord plugged in.	Plug in cord.
	Circuit breaker tripped in building.	Reset breaker.
	Faulty switch.	Call for service.
	Faulty power cord or pigtail.	Call for service.
Vacuum Motor Will Not Run	Vacuum circuit breaker tripped.	Reset breaker.
	Faulty main vacuum switch.	Call for service.
	Loose wiring.	Call for service.
	Faulty vac motor.	Call for service.
	Carbon brushes worn.	See "Brush Replacement" in maintenance section.
Vacuum Motor Runs But Suction Is Poor	Debris lodged in vac shoe.	Remove debris from vac shoe.
	Dome gasket defective or missing.	Replace as necessary.
	Vacuum hose cracked or hose cuff loose.	Replace or repair as necessary.
	Recovery tank full / float ball stuck in the up position.	Turn off vac motor. Drain and rinse recovery tank.
Poor Or No Water Flow(Carpet Is Streaky)	Main pump switch off.	Turn on.
	Jets clogged or missing.	Clean using a vinegar /water solution or replace.
	Solution filter clogged.	Drain solution tank and clean solution filter.
	Faulty solenoid.	Call for service.
Brush Does Not Spin	Brush switch off.	Turn on brush switch.
	Brush circuit breaker tripped.	Reset circuit breaker.
	Brush belt broken.	Replace as necessary.
	Faulty brush motor.	Call for service.

SUGGESTED SPARE PARTS

PART NO.	DESCRIPTION	SERIAL #	NOTES
260020	BRUSH, 18L X 3.38OD G2		Brush Assembly
260008	BELT, 180J6 MICRO-V		Brush Assembly
260080	JET BODY, MINI PROMAX BODY		Pump
260051	JET, MINI PROMAX 9504		Pump
260051	FLOAT, SHUT-OFF		Recovery Tank
260043	DOMES, S/C EXTRACTORS		Recovery Tank
260173	STRAINER, 3/8 IN. NPT 60 MESH		Solution Tank

NOTES

FRAME ASSEMBLY

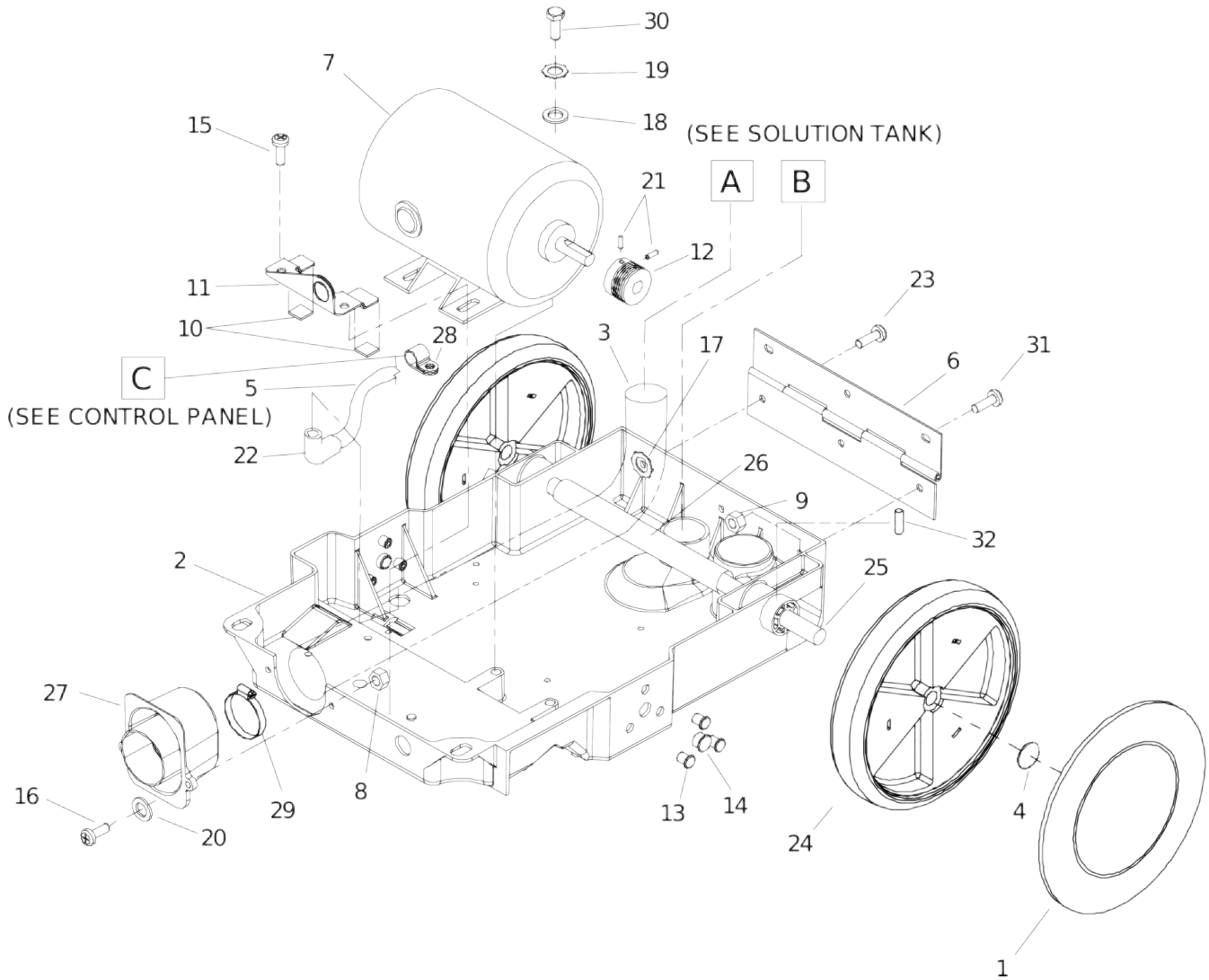

FRAME ASSEMBLY

REF	PART NO.	QTY	DESCRIPTION	SERIAL NO. FROM	NOTES:
1	260077	2	HUBCAP, 9.75" WHEEL, BLACK		
2	260053	1	FRAME, CLP FAMILY		
3	260068	1	HOSE ASSEMBLY 1.5 BLK VAC X 15.5		
4	260076	2	HUBCAP, 5/8" SHAFT		
5	260049	1	ELECTRICAL CABLE HARNESS		
6	260060	1	HINGE, TANK TO FRAME		
7	260089	1	MOTOR, 115V 1/3HP W/O T/O		
8	260096	2	*NUT, 10/32', ESNA		
9	260093	3	NUT, 1/4-20 HEX NYLOCK SS		
10	260052	2	FOAM TAPE, 1/8T X 3/4 1SDA		
11	260115	1	PLATE BRUSH CLAMP MTR		
12	260009	1	BELT PULLEY 1.4 OD, 6GR, MICRO-V		
13	260118	6	PLUG, HOLE, .375" BLK		
14	260117	2	PLUG, 9/16 OD BLK NYLON		
15	260128	2	SCREW, 1/4-20 X .58 PHPNHMS SS NP		
16	260148	2	SCREW, 10-32 X .75 PHPNHMS SS		
17	260094	3	NUT, 1/4-20 HEXSTRW LK STL ZNPLT		
18	260194	2	WASHER, 1/4 SS		
19	260189	2	WASHER 1/4 EXTLK SS		
20	260192	2	WASHER, .203 X .562 X .032 FLT		
21	260141	2	SCREW, 10-32 X .25 SCHSET KCP STL NP		
22	260171	1	STRAIN RELIEF, 90 DEGREES		
23	260134	1	SCREW, 1/4-20 X 1.25 PHPNHMS SS		
24	260197	2	WHEEL, 9.75" X 1.5"		
25	260002	1	AXLE 5/8 17.06L		
26	260059	10"	HEAT SHRINK, 3/4 ID UL/CSA		
27	260161	1	SEAL, FRAME/TANK		
28	260024	1	CLAMP, 7/16 DIA NYLON UL		
29	260026	1	CLAMP, 2.0" WORM GEAR		
30	260140	2	SCREW, 10-24 X .5 SCHCS SS		
31	260133	2	SCREW, 1/4-20 X 1 PHPNHMS SS		
32	260111	1	PIN, ROLL 1/8 X 1 SS		

BRUSH ASSEMBLY

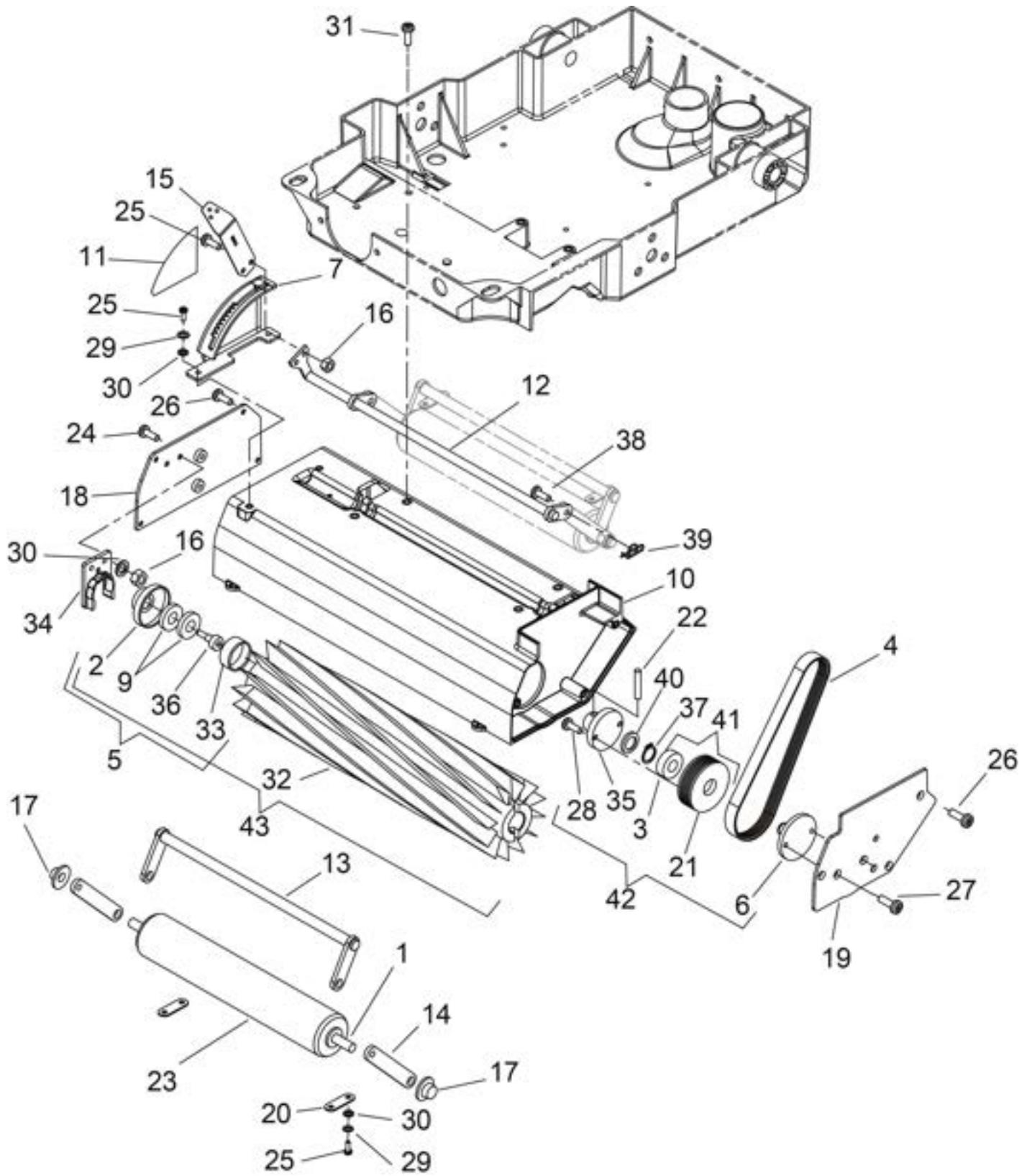

BRUSH ASSEMBLY

REF	PART NO.	QTY	DESCRIPTION	SERIAL NO. FROM	NOTES:
1	260003	1	AXLE ROLLER		
2	260006	2	BEARING, R6 3/8 ID		
3	260007	2	BEARING,.500 X 1.125 X .375 BALL 2RS		
4	260008	1	BELT, 180J6 MICRO-V		
5	REF	REF	KIT, BRNG/ADPTR EXTRCTR		
6	260018	1	BRKT, BRUSH PULLEY		
7	260017	1	BRKT, BRUSH HEIGHT		
8	260053	REF	FRAME, CLP FAMILY		
9	260007	1	BRUSH BEARING ASM		
9	REF	REF	BRUSH BEARING ASM		
10	260075	1	HOUSING, BRUSH 18"		
11	260085	1	LABEL, BRUSH HEIGHT		
12	260088	1	LEVERAGE COMPLETE BRUSH HEIGHT		
13	260175	1	SUPPORT ROLLER ASSEMBLY		
14	260124	2	ROLLER FRONT LINK		
15	260087	1	LEVER, HEIGHT ADJUSTMENT		
16	260096	4	*NUT, 10/32', ESNA		
17	260097	2	NUT, 3/8 DIA CAP, TYPE PUSH PLT		
18	260106	1	PAINT PLATE BRUSH HOUSING RH		
19	260105	1	PAINT PLATE BRUSH HOUSING LH		
20	260114	2	PLATE, AXLE RETAINER		
21	260119	1	PULLEY, 2.2 OD, 6GR, MICRO-V		
22	260011	1	PIN, ROLL 1/4 X 1.25L		
23	260123	1	ROLLER, 1.9 DIA X 10.5 LG		
24	260147	2	SCREW, 10-32 X .625 PHFLHMS SS NP		
25	260146	6	SCREW, 10-32 X .5 PHPNHMS SS NP		
26	260145	7	SCREW, 10-32 X .5 PHFLHMS SS		
27	260142	2	SCREW, 10-32 X .375 PHFLHMS SS		
28	260140	2	SCREW, 10-24 X .5 SCHCS SS		
29	260188	4	WASHER, #10 LOCK EXT STAR SS		
30	260192	6	WASHER, #10 X 9/16 OD		
31	260130	4	SCR, 1/4-20 X.5/8 THMS PLTD NP		
32	260182	1	RING, TOLERANCE 7/8 ID X 1/2 W		
33	260020	1	BRUSH,18L X 3.38 OD G2		
34	260029	1	CLIP, BEARING		
35	260112	1	PINION BRUSH		
36	260163	1	SHOULDER BOLT, 3/8 X .375L SS		
37	260121	1	RING, 1/2 EXT. SNAP		
38	260108	2	PIN, CLEVIS 1/4 X 1/2 PLTD		
39	260109	2	COTTER, 1/4" RING		
40	260165	1	SPACER, .81 X 1.06 X .125		
41	REF	1	PULLEY ASM, BRUSH		
42	REF	1	DRIVER ASM, BRUSH		
43	REF	1	BRUSH ASM, 18 IN		
44	260001	1	ADAPTER BRUSH BRG DIE CAST		

PUMP ASSEMBLY

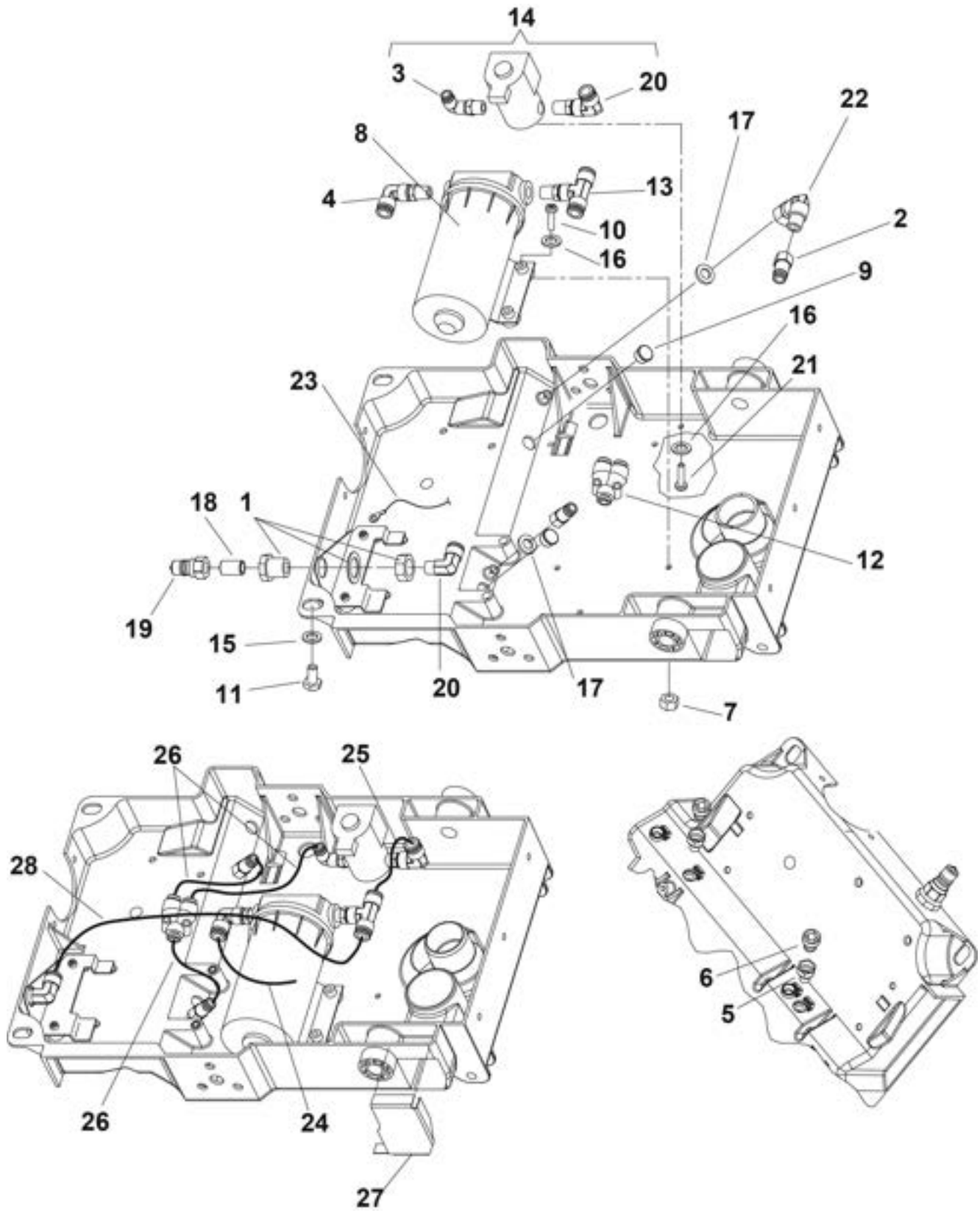

PUMP ASSEMBLY

REF	PART NO.	QTY	DESCRIPTION	SERIAL NO. FROM	NOTES:
1	260038	1	COUPLING, 1/4 ANCHOR W/1" HEX		
2	260032	2	CONNECTOR, 1/8FPT X 1/4 TUBEQC		
3	REF	1	ELBOW, SWIVEL, 1/4MPTX1/4TUBE		
4	260045	1	ELBOW, SWIVEL, 3/8MPTX3/8TUBEQC		
5	260079	2	JET BODY, MINI PROMAX BODY		
6	260080	2	JET, MINI PROMAX 9504		
7	260096	2	*NUT, 10/32', ESNA		
8	260120	1	PUMP, 115V 100PSI BYPASS		
9	260117	2	PLUG, 9/16 OD BLK NYLON		
10	260150	2	SCR, 10-32 X 1.25 PPHMS		
11	260129	2	SCR, 1/4-20 X 5/8 HHCS SS		
12	260050	1	FITTING, 1/4 TUBE,"Y", QC		
13	260180	1	TEE, 3/8 MPT X 3/8 TUBE, QC		
14	260186	1	VALVE ASM. 120V CLP FAMILY		
15	260193	2	WASHER, 1/4"IDX1.0OD. FLAT SS		
16	260192	4	WASHER, #10 X 9/16 OD		
17	260191	2	WASHER, 7/16 X 3/4 X .19RUBBER		
18	260090	1	NIPPLE, 1/4 CLOSE		
19	260091	1	NIPPLE, 1/4 FPT QD		
20	260046	2	ELBOW, 1/4 MPT X 3/8 TUBE, QC		
21	260143	2	SCR, 10-32 X 3/8 PPHMS SS		
22	260047	1	ELBOW, 1/8 NPT STREET		
23	260203	1	WIRE, 22" GRN/18 76011 X 76011		
24	260064	1	HOSE, 3/8 URETHANE X 29"		
25	260065	1	HOSE, 3/8 NYLON X 6"		
26	260063	3	HOSE, 1/4 URETHANE X 6"		
27	260126	1	SCREEN, INTAKE		
28	260066	1	HOSE, 3/8 ID NYL11 YLW X 29"		

VACUUM SHOE ASSEMBLY

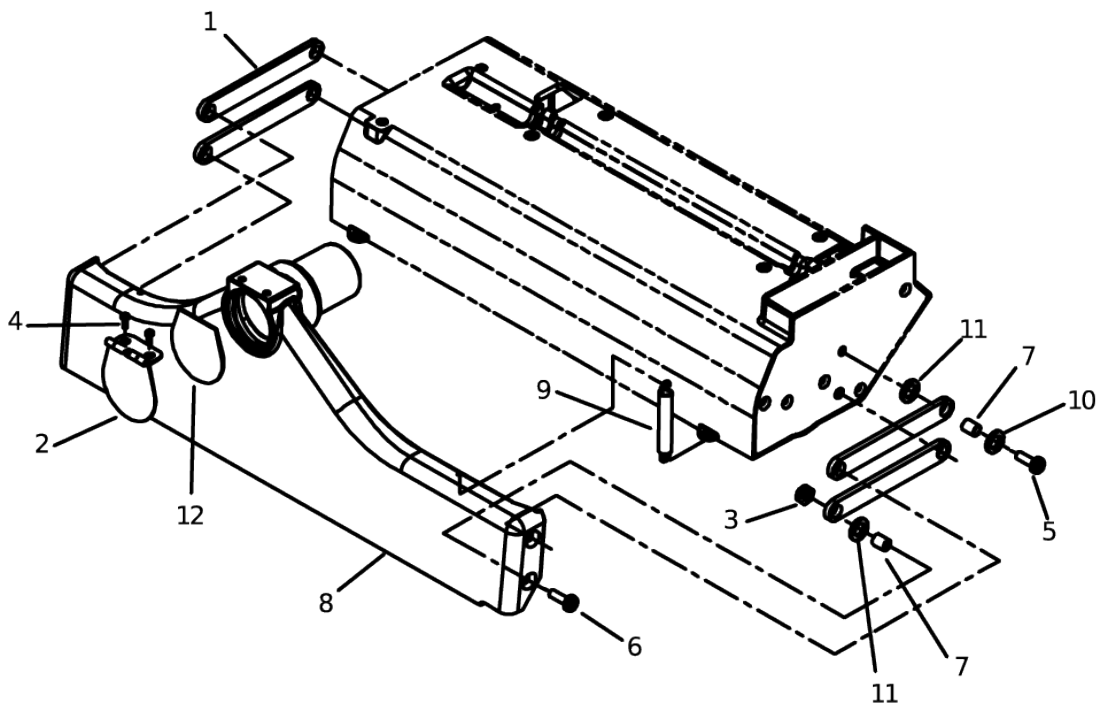

VACUUM SHOE ASSEMBLY

REF	PART NO.	QTY	DESCRIPTION	SERIAL NO. FROM	NOTES:
1	260014	4	BRACKET ARM PARALLEL SHOE VACUUM		
2	260042	1	COVER, ACCESSORY PORT		
3	260093	4	NUT, 1/4-20 HEX NYLOCK SS		
4	260144	2	SCR, 10-32 X 3/8 HHTR W/STAR		
5	260131	4	SCR, 1/4-20 X.75 PPHMS PHIL		
6	260132	4	SCR, 1/4-20 X 1 FHCS PLTD		
7	260164	8	SPACER, 3/8ODX.058WX.2814,CRS		
8	260185	1	VAC SHOE, 18"		
9	260169	2	SPRING, EXT .38D X2.75L X.055W		
10	260194	4	WASHER, 1/4 ID X 5/8 OD SS		
11	260195	8	WASHER, WAVE 3/8ID X3/4D X.125		
12	260154	1	GASKET, ACCESSORY PORT		

CONTROL PANEL ASSEMBLY

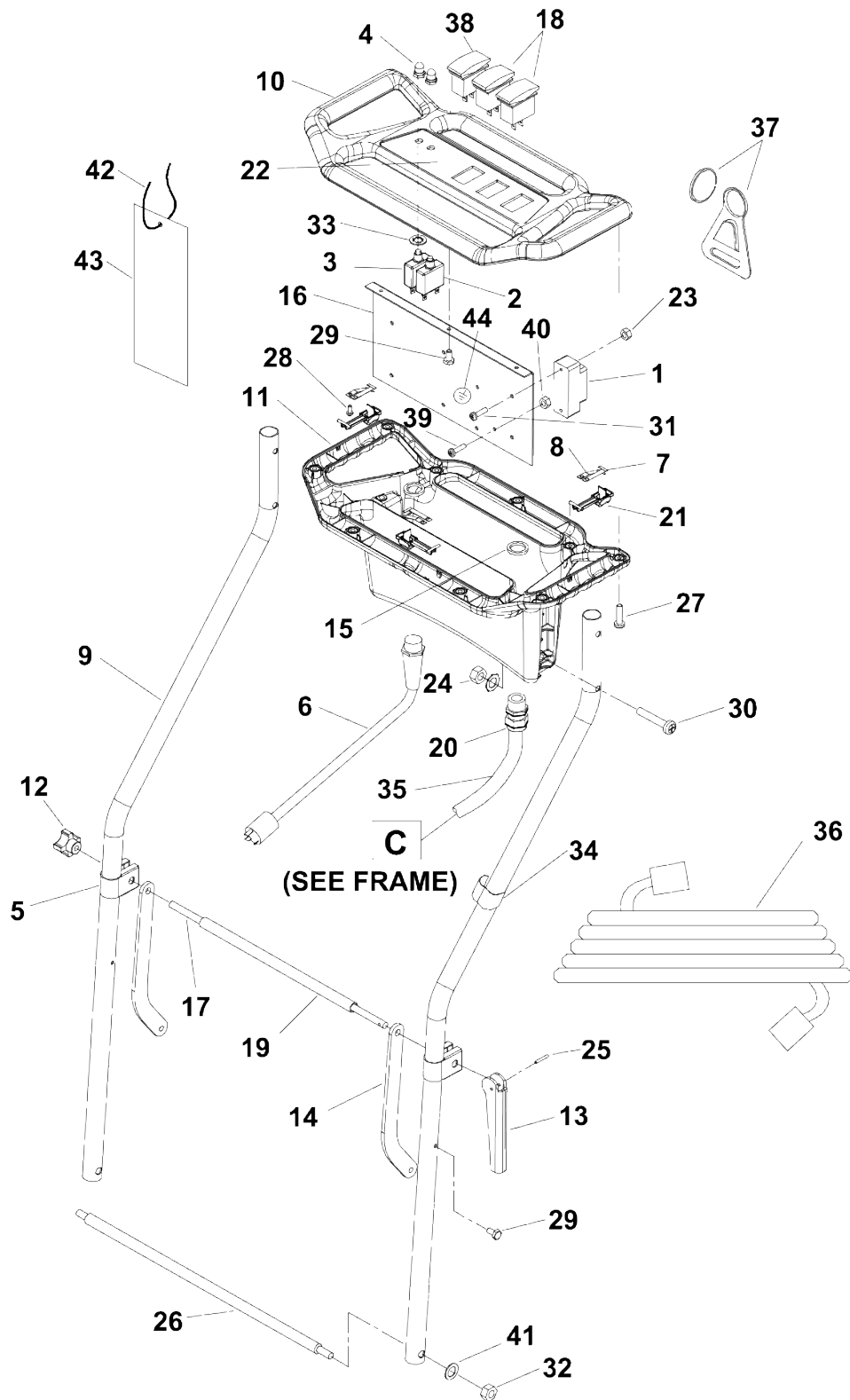

CONTROL PANEL ASSEMBLY

REF	PART NO.	QTY	DESCRIPTION	SERIAL NO. FROM	NOTES:
1	260174	1	TERMINAL BLOCK, 115V (3-4-3)		
2	260015	1	BREAKER, 15A 250VAC 50VDC		
3	260016	1	BREAKER, 6A VDE CIRCUIT		
4	260013	2	BOOT, 3/8 CIRCUIT BREAKER		
5	260102	2	PAINT HANDLE LOCK CLAMP		
6	260035	1	CORD ASM, 14/3 X 22" YLW		
7	260034	3	CONTACT, ELECTRICAL, FLAT		
8	260033	3	CONTACT, ELECTRICAL, BENT		
9	260101	2	PAINT HANDLE ADM 8		
10	260055	1	HANDLE, CONTROL PANEL FRONT		
11	260056	1	HANDLE, CONTROL PANEL REAR		
12	260081	1	KNOB, 5/16-18 4 PRONG		
13	260103	1	PAINT LEVER HANDLE CLAMP		
14	260100	2	PAINT HANDLE ADJUSTMENT LINK		
15	260092	2	NUT, 1/2 NPT CONDUIT		
16	260116	1	PLATE, CONTROL PANEL, CLP/ADM		
17	260104	1	PAINT LOCK HANDLE ROD		
18	260177	2	SWITCH, SPST 2-POSITION ROCKER		
19	260107	1	PAINT SPACER .50 ODX.058WX9.84L		
20	260172	1	STRAIN RELIEF, STRT,LQ TITE 3200,(876029)		
21	260183	3	TRIGGER, SWITCH		
22	260082	1	LABEL CONTROL PANEL SCE-20		
23	260099	2	NUT, 6-32 W/STAR WASHER PLTD		
24	260093	4	NUT, 1/4-20 HEX NYLOCK SS		
25	260110	1	PIN, ROLL 1/8" X 5/8"L		
26	260004	1	AXLE, HANDLE ADM8		
27	260136	9	SCR, #10 X 3/4 PPHST TYPE B		
28	260151	6	SCR, 6-32 X 1/4 PPHMS SS		
29	260144	5	SCR, 10-32 X 3/8 HHTR W/STAR		
30	260135	4	SCR, 1/4-20 X 1.75 PPHMS SS		
31	260152	2	SCR, 6-32 X 1.0 PH BLK NYLON		
32	260098	2	NUT, 5/16-18, ESNA		
33	260190	2	WASHER, 3/8 ID INT.LOCK THIN		
34	260030	2	CLIP, POWER CORD		
35	260049	REF	ELECTRICAL CABLE HARNESS		
36	260036	1	CORD SET,14/3 SJTW-A X 50' YLW		
37	260122	1	RING WITH CORD HOOK		
38	260176	1	SWITCH, DPDT3-POSITION ROCKER		
39	260149	1	SCR, 10-32 X 1" PPHMS		
40	260095	1	NUT, 10/32" KEPS		
41	260196	1	WASHER, 5/16 FLT SS		
42	260037	2	CORD, 1/8" X 12~		
43	260078	1	INSTRUCTION CARD SCE-20		
44	260083	1	LABEL, GROUND SYMBOL		

SOLUTION TANK ASSEMBLY

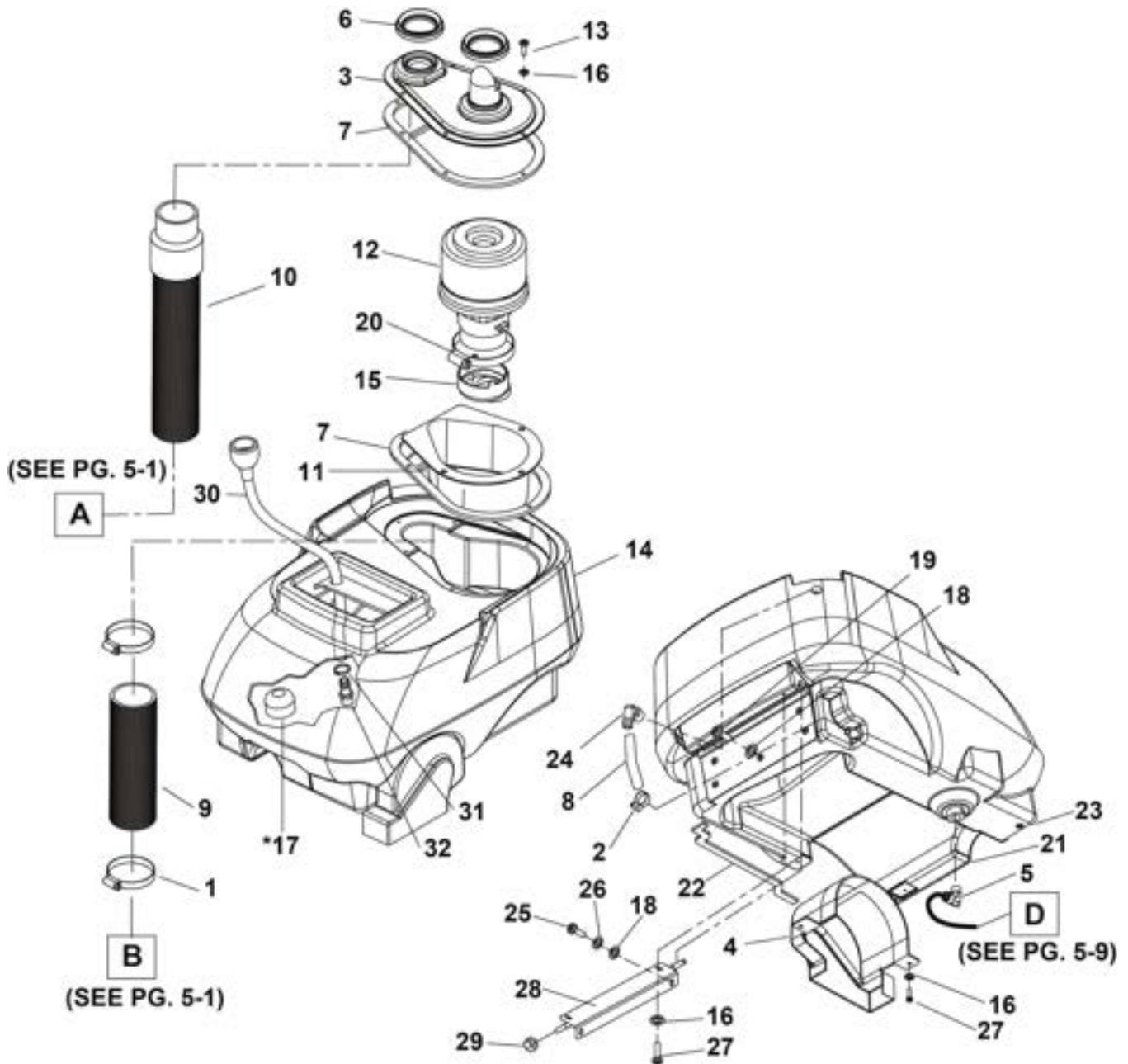

SOLUTION TANK ASSEMBLY

REF	PART NO.	QTY	DESCRIPTION	SERIAL NO. FROM	NOTES:
1	260026	2	CLAMP, 2.0" WORM GEAR		
2	260028	1	CLAMP, 3/8 HOSE (D-SLOT)		
3	260039	1	COVER, VAC MOTOR		
4	260040	1	COVER, BELT		
5	260048	1	ELBOW, 3/8 MPT X 3/8 TUBE, PLASTIC		
6	260155	2	GASKET, TANK TO VAC COVER		
7	260156	2	GASKET, VAC COVER		
8	260070	1	HOSE, 1/2 CLEAR X 12		
9	260061	1	HOSE, 1.5 BLK VAC X 5.0		
10	260068	REF	HOSE ASM, 1.5 BLK VAC X 15.5		
11	260074	1	HOUSING, VAC MOTOR		
12	260184	1	VAC MOTOR, 240V 5.7 3ST LNP		
-	REF		BRUSH SET, 120V VAC		SERVICE ONLY
13	260138	6	SCR, #10 X 1.0 PPHST TYPE B		
14	260178	1	Tank BRC 46/38 black solution		
15	260187	1	VENT, COOLING AIR LARGE		
16	260192	10	WASHER, #10 X 9/16 OD		
17	260173	1	STRAINER, 3/8 IN. NPT 60 MESH		
18	260194	5	WASHER, 1/4 ID X 5/8 OD SS		
19	260128	3	SCR, 1/4-20 X 1/2 PPHMS SS DL		
20	260027	1	CLAMP, 3.5" WORM GEAR		
21	260158	1	GASKET, TANK, L-F		
22	260159	1	GASKET, TANK, L-R		
23	260160	1	GASKET, TANK, RH		
24	260073	1	HOSEBARB, 3/8MPTX1/2 90D DL		
25	260131	2	SCR, 1/4-20 X.75 PPHMS PHIL		
26	260189	2	WASHER, 1/4 LOCK EXT STAR SS		
27	260137	4	SCR, #10 X 3/4 PPHST TYPE B		
28	260113	1	Pivot Handle Weldment ADM8		
29	260093	2	NUT, 1/4-20 HEX NYLOCK SS		
30	260067	1	HOSE ASSY- FILL HOSE		
31	260025	1	CLAMP, 1/4 ID HOSE		
32	260072	1	HOSEBARB, 1/2MPT X 3/8 DL		

RECOVERY TANK ASSEMBLY

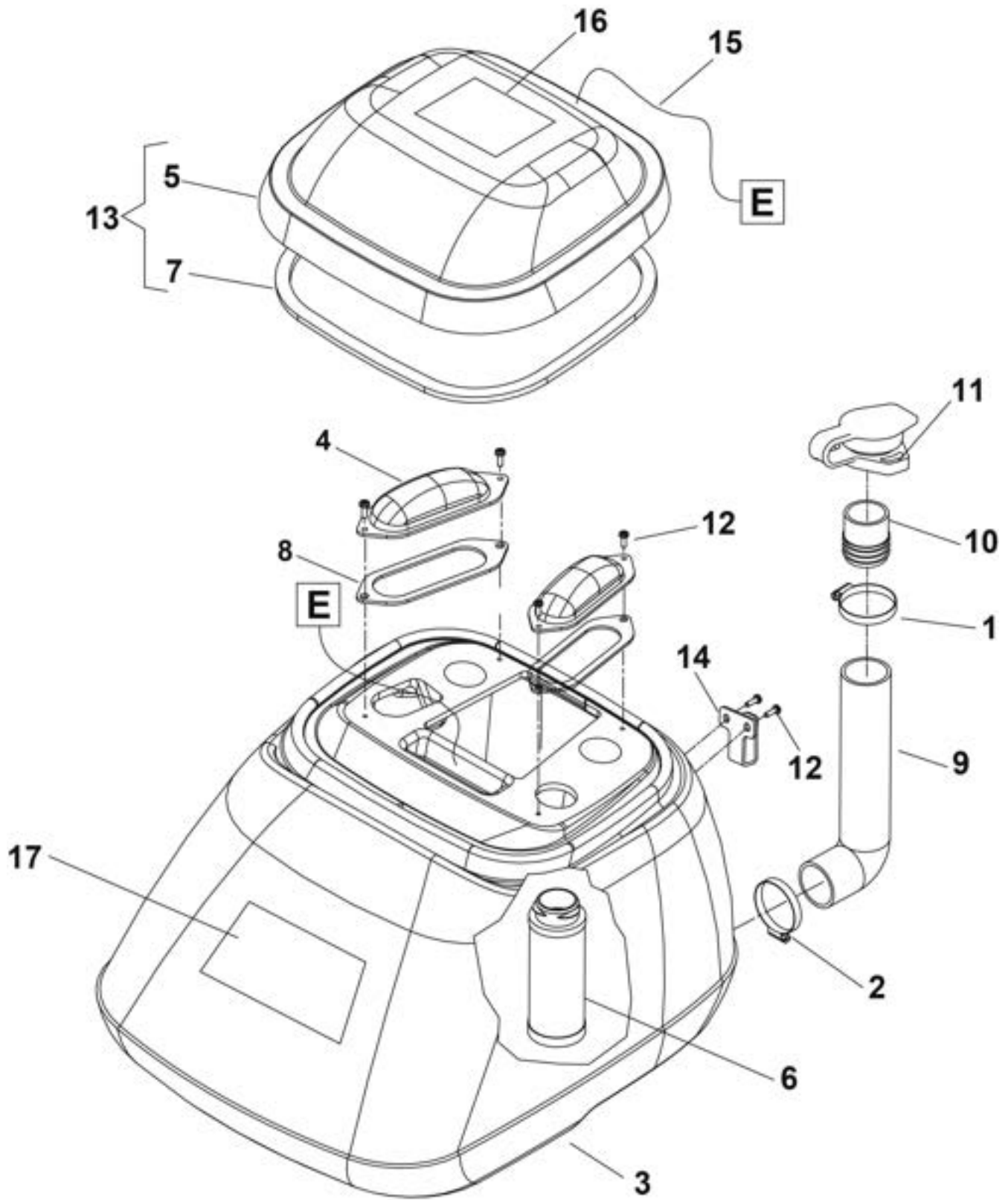

RECOVERY TANK ASSEMBLY

REF	PART NO.	QTY	DESCRIPTION	SERIAL NO. FROM	NOTES:
1	260023	1	CLAMP, 2.0" WORM GEAR X .312		
2	260026	1	CLAMP, 2.0" WORM GEAR		
3	260179	1	TANK BRC 46/38 BLUE RECOVERY		
4	260041	2	COVER, REC. TANK		
5	260043	1	DOME		
6	260051	1	FLOAT SHUT-OFF		
7	260054	1	GASKET, DOME		
8	260157	2	SEAL		
9	260062	1	HOSE, 1.5 X 12.0 DRAIN		
10	260069	1	HOSE, INSERT		
11	260071	1	HOSE CAP		
12	260137	6	SCR, #10 X 3/4 PPHST TYPE B		
13	260043	1	DOME ASM		
14	260019	1	BRKT, HOSE HOOK		
15	260037	1	CORD, 99807 1/8 X 12"		
16	260086	1	LABEL, WARNING		
17	260084	1	LABEL LOGO BLUE SCE-20		

SUGGESTED SPARE PARTS

PART NO.	DESCRIPTION	SERIAL # FROM	NOTES:
260020	BRUSH, 15L X 3.38OD		
260008	BELT, 180J6 MICRO-V		
260007	BEARING, 1.125ODX.500IDX.375		
260079	JET BODY, MINI PROMAX BODY		
260080	JET, MINI PROMAX 9503		
260154	GASKET, ACCESSORY PORT		
260015	BREAKER, 15A 250VAC 50VDC		
260016	BREAKER, 6A VDE CIRCUIT		
260177	SWITCH, SPST 2-POSITION ROCKER		
260176	SWITCH, DPDT3-POSITION ROCKER		
260173	STRAINER, 3/8 IN. NPT 60 MESH		
260051	FLOAT SHUT-OFF		

WIRING DIAGRAM

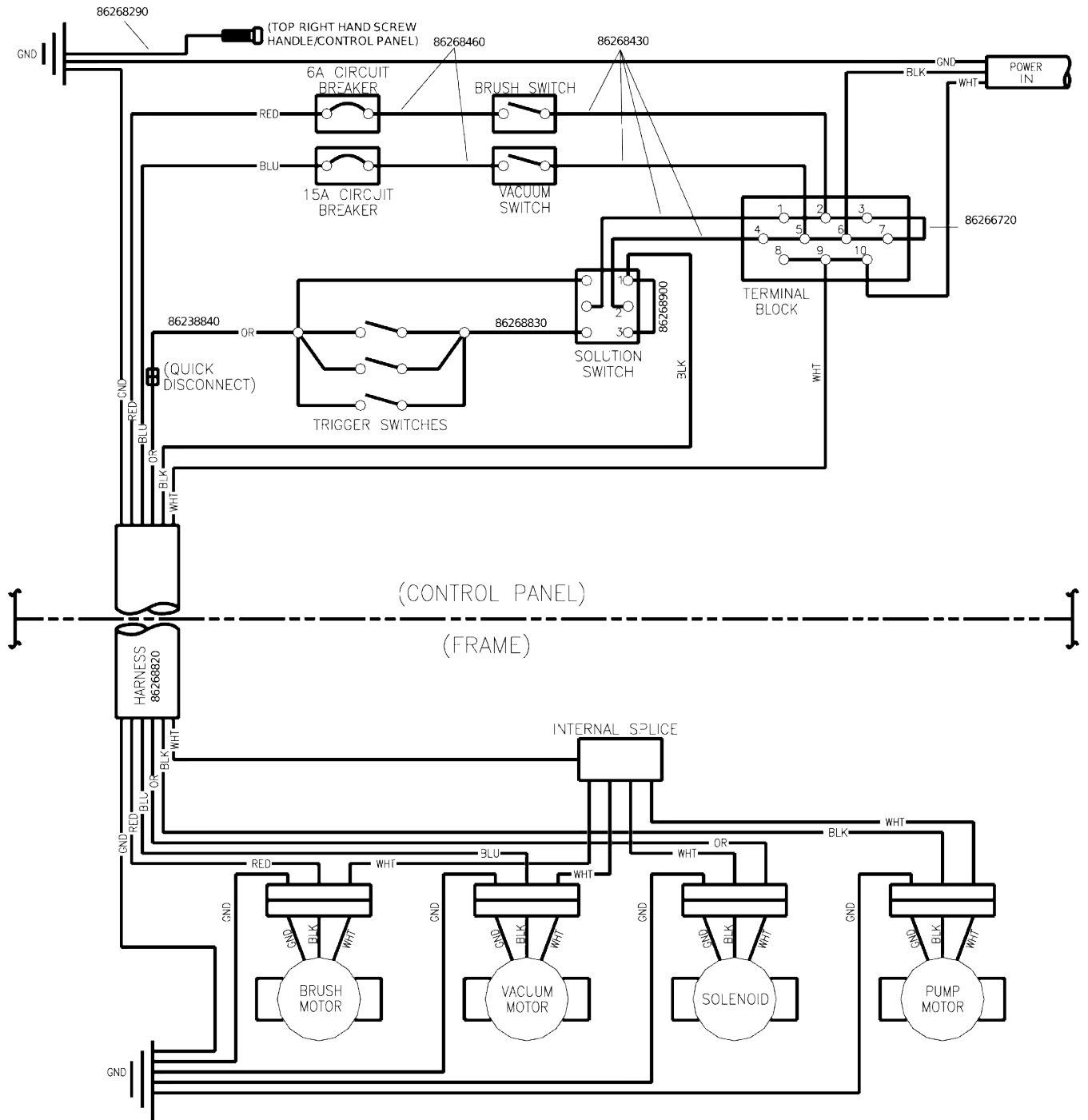

SUGGESTED SPARE PARTS

# MODEL: SERIAL	.REF .NO
N/A	1

If you see a Ref number with an (*) in either the "Serial number from" column or "Serial number to" column in a Parts list, it is referring to the serial numbers with the corresponding Ref number in this Serial number List. The serial number indicates the first machine the part number is applicable to. The main illustration shows the most current design of the machine. When a boxed illustration is shown, it displays the older design.