



PACIFIC[®]
F L O O R C A R E

S-24 / S-28 / S-32

22 GALLON MID-SIZE AUTOSCRUBBER



Thank you for purchasing a Pacific Floorcare product. Carefully inspect all components for freight damage. If such damage is discovered, file a “CONCEALED DAMAGE REPORT” immediately with the delivering carrier.

Read this manual carefully and keep it near the machine, protected from liquids and other damaging substances. Failure to follow the instructions may result in injury or damage to equipment and property.

The contents of this manual are based on the latest product information available at the time of publication. Pacific Floorcare reserves the right to make changes or improvements without being obliged to apply changes to the machines previously sold.

New manuals can be downloaded from: www.pacificfloorcare.com/manuals

22 GALLON AUTOSCRUBBER SPECIFICATIONS

Features	Specifications	
Model:	S-24 (Disk)	S-28 (Orbital)
Solution Delivery System		
Solution capacity:	22 gal / 83 l	22 gal / 83 l
Solution control: (Standard)	0-.55 gpm / 0-2.1 lpm, Variable knob adjustment	0-.55 gpm / 0-2.1 lpm, Variable knob adjustment
Solution control: (w/ Chemical Injection)	Low, Med & High flow settings (.10, .25 & .45 gpm / .38, .95 & 1.7 lpm) Speed Sensitive Flow or Constant Output Flow Control	Low, Med & High flow settings (.10, .25 & .45 gpm / .38, .95 & 1.7 lpm) Speed Sensitive Flow or Constant Output Flow Control
Scrubbing System		
Cleaning path:	24 in / 610 mm	28 in / 711 mm
Pad/brush size:	(2) 12 in / 305 mm	(1) 28 x 14 in / 711 x 356 mm
Productivity (per hour)-Theoretical max:	26,400 ft	30,800 ft
Productivity (per hour)-Average coverage rate:*	19,525 ft	22,425 ft
Brush Drive System		
Brush motor horsepower (each):	(1) 1 hp / 750 W	(1) 1 hp / 750 W
Brush rpm:	360 rpm	2,200 rpm
Brush/pad pressure:	50, 100 & 140 lb / 23, 45 & 64 kg	70, 110 & 160 lb / 32, 50 & 73 kg
Brush/pad attachment/removal:	Automatic on/off	Manual
Recovery System		
Recovery tank accessibility:	Full clean out access	Full clean out access
Recovery tank capacity:	25 gal / 95 l (3 gal / 11.4 l demisting chamber)	25 gal / 95 l (3 gal / 11.4 l demisting chamber)
Vacuum motor:	.7 hp / 522 W, 3-stage	.7 hp / 522 W, 3-stage
Vac motor cfm / cmm:	71 cfm / 2.0 cmm	71 cfm / 2.0 cmm
Vac motor water-lift:	71 in / 180 cm	71 in / 180 cm
Standard / Narrow Aisle Squeegee width:	35 / 30 in (89 / 76 cm)	40 / 35 in (102 / 89 cm)
Drive System		
Drive Type:	Transaxle Drive	Transaxle Drive
Motor horsepower:	.5 hp / 373 W	.5 hp / 373 W
Battery System		
System voltage:	24 V	24 V
Battery amp hour rating:	(4) 6V: 260 AH (wet) / 250 AH (MF)	(4) 6V: 260 AH (wet) / 250 AH (MF)
Battery run time:	Up to 5.5 hours	Up to 5.5 hours
Charger description:	On-board (standard) Off-board (optional)	On-board (standard) Off-board (optional)
Machine specifications		
Product length:	54 in / 137 cm	52 in / 132 cm
Product width (without squeegee):	26 in / 66 cm	28 in / 71 cm
Product height:	44 in / 112 cm	44 in / 112 cm
Product weight (with batteries):	650 lb / 295 kg	665 lb / 302 kg
Sound level (operator's ear):	65 dBA	63 dBA
Construction:	Rotationally molded polyethylene tanks, powder coated steel frame	Rotationally molded polyethylene tanks, powder coated steel frame
<i>*Productivity calculations utilize key factors from ISSA 540 cleaning times handbook</i>		
<i>Note: Specifications subject to change without notice</i>		

22 GALLON AUTOSCRUBBER SPECIFICATIONS

Features	Specifications	
Model:	S-28 (Disk)	S-32 (Disk)
Solution Delivery System		
Solution capacity:	22 gal / 83 l	22 gal / 83 l
Solution control: (Standard)	0-.55 gpm / 0-2.1 lpm, Variable knob adjustment	0-.55 gpm / 0-2.1 lpm, Variable knob adjustment
Solution control: (w/ Chemical Injection)	Low, Med & High flow settings (.10, .25 & .45 gpm / .38, .95 & 1.7 lpm) Speed Sensitive Flow or Constant Output Flow Control	Low, Med & High flow settings (.10, .25 & .45 gpm / .38, .95 & 1.7 lpm) Speed Sensitive Flow or Constant Output Flow Control
Scrubbing System		
Cleaning path:	28 in / 711 mm	32 in / 813 mm
Pad/brush size:	(2) 14 in / 356 mm Disks	(2) 16 in / 406 mm Disks
Productivity (per hour)-Theoretical max:	30,800 ft	35,200 ft
Productivity (per hour)-Average coverage rate:*	22,425 ft	25,125 ft
Brush Drive System		
Brush motor horsepower (each):	(2) 1 hp / 750 W	(2) 1 hp / 750 W
Brush rpm:	300 rpm	300 rpm
Brush/pad pressure:	70, 110 & 150 lb / 32, 50 & 68 kg	70, 110 & 150 lb / 32, 50 & 68 kg
Brush/pad attachment/removal:	Automatic on/off	Automatic on/off
Recovery System		
Recovery tank accessibility:	Full clean out access	Full clean out access
Recovery tank capacity:	25 gal / 95 l (3 gal / 11.4 l demisting chamber)	25 gal / 95 l (3 gal / 11.4 l demisting chamber)
Vacuum motor:	.7 hp / 522 W, 3-stage	.7 hp / 522 W, 3-stage
Vac motor cfm / cmm:	71 cfm / 2.0 cmm	71 cfm / 2.0 cmm
Vac motor water-lift:	71 in / 180 cm	71 in / 180 cm
Standard / Narrow Aisle Squeegee width:	40 / 35 in (102 / 89 cm)	44.5 / 40 in (113 / 102 cm)
Drive System		
Drive Type:	Transaxle Drive	Transaxle Drive
Motor horsepower:	.5 hp / 373 W	.5 hp / 373 W
Battery System		
System voltage:	24 V	24 V
Battery amp hour rating:	(4) 6V: 260 AH (wet) / 250 AH (MF)	(4) 6V: 260 AH (wet) / 250 AH (MF)
Battery run time:	Up to 4.5 hours	Up to 4.0 hours
Charger description:	On-board (standard) Off-board (optional)	On-board (standard) Off-board (optional)
Machine specifications		
Product length:	56 in / 142 cm	58 in / 147 cm
Product width (without squeegee):	30 in / 76 cm	34 in / 86 cm
Product height:	44 in / 112 cm	44 in / 112 cm
Product weight (with batteries):	660 lb / 299 kg	665 lb / 302 kg
Sound level (operator's ear):	65 dBA	65 dBA
Construction:	Rotationally molded polyethylene tanks, powder coated steel frame	Rotationally molded polyethylene tanks, powder coated steel frame
*Productivity calculations utilize key factors from ISSA 540 cleaning times handbook		
Note: Specifications subject to change without notice		

TABLE OF CONTENTS

SAFETY INFORMATION	1
UNPACKING THE MACHINE	3
TRANSPORTING THE MACHINE	4
BATTERIES	5
SERVICING LEAD ACID BATTERIES (NON-HYDROLINK® MODELS).....	6
SERVICING LEAD ACID BATTERIES WITH HYDROLINK®	7
WATERING SYSTEM	7
BATTERYSHIELD® AUTOMATED WET BATTERY PROTECTION SYSTEM.....	8
CHARGING	10
ON-BOARD CHARGING	10
OFF-BOARD CHARGER	11
OPERATION	12
MACHINE OVERVIEW	12
PRE-USE SETUP	13
OPTIONAL SCRUBSMART TELEMETRY SYSTEM	14
ORBITAL PADS & CHEMICAL-FREE FINISH REMOVAL (CFR).....	18
DISK MACHINE PAD DRIVERS & BRUSHES	19
SQUEEGEE SYSTEM	21
RECOMMENDED MAINTENANCE	23
RECOMMENDED SERVICE PARTS	24
TROUBLESHOOTING GUIDE	27
PARTS DIAGRAMS	29
BATTERIES, BATTERYSHIELD® & HYDROLINK®	29
OPTIONAL ONBOARD CHARGER	30
CONTROLS.....	31
OPTIONAL BATTERYSHIELD® & CHEMICAL INJECTION CONTROLS.....	37
OPTIONAL SCRUBSMART® TELEMETRY SYSTEM	38
ELECTRONICS.....	39
FRAME ASSEMBLY	43
HEAD LIFT	45
SOLUTION TANK.....	47
OPTIONAL CHEMICAL INJECTION SYSTEM.....	49
RECOVERY TANK ASSEMBLY	51
SQUEEGEE LINKAGE	55
SQUEEGEE ASSEMBLIES.....	56
S-24 DISK SCRUB HEAD	59
S-28 DISK SCRUB HEAD	63
S-32 DISK SCRUB HEAD	67
S-28 ORBITAL SCRUB HEAD	71
WIRING DIAGRAMS	73
S-24 DISK	73
S-28 & S-32 DISK.....	75
S-28 ORBITAL.....	77
OPTIONAL BATTERYSHIELD® SYSTEM	79
OPTIONAL CHEMICAL INJECTION SYSTEM.....	80
OPTIONAL SCRUBSMART® TELEMETRY SYSTEM	81

PAGE INTENTIONALLY BLANK

SAFETY INFORMATION

This machine is intended for commercial use. Only use recommended pads or brushes and commercially approved floor cleaning chemicals intended for machine application.

WARNING: A potentially hazardous situation that, if not avoided, could result in death or serious injury.

CAUTION: A potentially hazardous situation that, if not avoided, could result in moderate injury or serious property damage.

NOTE: Information that will prevent premature equipment failure or minor property damage.

WARNING: This product can expose you to chemicals including lead and lead compounds which are known to the State of California to cause cancer and birth defects or other reproductive harm. For more information go to www.P65Warnings.ca.gov.

WARNING: This machine is not equipped with explosion proof motors. Never use near flammable or reactive materials, liquids, vapors or combustible dusts. Electric motors spark internally during operation and could cause a flash fire or explosion.

WARNING: Batteries emit hydrogen and oxygen gas.

- Keep sparks and open flame away.
- Do not smoke near the machine.
- Charge batteries in a well-ventilated area with the battery compartment open.

WARNING: Do not plug in the charger cable if wall cord or battery harness is damaged.

WARNING: Disconnect battery cables before servicing.

WARNING: Do not wear jewelry when working near moving or electrical components.

WARNING: Do not use the machine as a means for transport.

WARNING: Never allow children to play on or around machine.

WARNING: Do not bump into shelves or scaffoldings, especially where there is a risk of falling objects.

WARNING: Support the machine on safety stands before working underneath.

WARNING: Do not operate the machine:

- Unless trained and authorized.
- Unless operator manual has been fully read and understood.
- While using cell phones or other electronic devices.
- Under the influence of drugs or alcohol.
- With any part of the machine not functioning properly.
- In areas where flammable vapors, liquids, or combustible dusts are present.
- In low light areas where the operators vision is impaired.
- In areas with possible falling objects.

WARNING: Before operating the machine:

- Check the machine and batteries for fluid leaks.
- Check the steering and brake systems for proper operation.

WARNING: While operating the machine:

- Operate the machine only as described in this manual.
- Allow the machine to fully stop before getting off.
- Keep all body parts inside the machine while moving.
- Do not carry passengers on the machine.
- Follow all safety instructions and guidelines specific to your facility or environment.

SAFETY INFORMATION CONTINUED

- CAUTION:** Keep hands away from spinning brushes.
- CAUTION:** Do not modify the machine from its original design.
- CAUTION:** Wear non-slip shoes when operating machine.
- CAUTION:** Reduce speed when turning or operating on inclines and slippery surfaces.
- CAUTION:** Use Bromine only in your tank treatment system! Do not use chlorine. Chlorine can interact with ammonia-based detergents and cause harmful fumes.
- CAUTION:** Follow mixing and handling instructions on chemical containers.
- CAUTION:** Remove the batteries, use a jack, and get assistance before lifting the machine.
- CAUTION:** Park and service the machine on a level surface and remove the key.
- CAUTION:** Always wear protective clothing, gloves and goggles when handling and charging batteries.
- CAUTION:** Avoid moving parts and do not wear loose jackets, shirts or sleeves when servicing.
-
- NOTE:** Do not hose down or use a power-spray on the machine. Electrical malfunction may occur.
- NOTE:** All repairs must be performed by a qualified service technician using approved replacement parts.
- NOTE:** To avoid damaging the floor, do not allow the brush/pad to operate while the machine is stationary.
- NOTE:** Use a ramp with no more than a 12% incline when loading or unloading the machine.
- NOTE:** Use tie down straps to secure the machine to the truck or trailer during transport.
- NOTE:** Discontinue use and report machine damage or faulty operation immediately.
- NOTE:** Store the machine indoors where the temperature is between 32° and 104°F (0° and 40°C).
- NOTE:** Do not lower the orbital head without a pad. Doing so damages the Mighty-Lok® face.
- NOTE:** Failure to clean the BatteryShield® light pipe will limit the system's ability to read the water level and will reduce battery life.
- NOTE:** Do not use an extension cord. This will void the warranty on the charger.
- NOTE:** Batteries designed for automotive or marine and RV use are not suited for use in floor scrubbers.
- NOTE:** Use of an unapproved water supply or modification of an approved water supply can lead to battery system failure.
- NOTE:** Ensure battery charging and storage locations comply with OSHA and any governing agencies' standards based on your particular location and application.
- NOTE:** When loading/unloading machine for transport:
- Fully drain the Solution and Recovery tanks before loading.
 - Transport the machine with the scrub head in the lowered.
 - Ensure the ramp and truck/trailer are properly rated for the weight of the machine.
 - Do not lower the Orbital Scrub Head without a pad installed.
 - Chock the wheels and tie down the machine.

UNPACKING THE MACHINE

1. Remove outer cardboard packaging.
2. Remove the shrink wrap securing the ramp and allow the ramp (not shown) to lower to the ground.
3. Using a #2 Philips driver, remove the screws from the front and rear wood wheel chocks.
4. Using a 3/8" socket and driver or wrench, remove the screws from the tie-down straps located at each corner of the machine.
5. Raise the scrub head to the transport position.
6. Carefully maneuver the machine down the ramp.
7. Install the rear squeegee assembly.

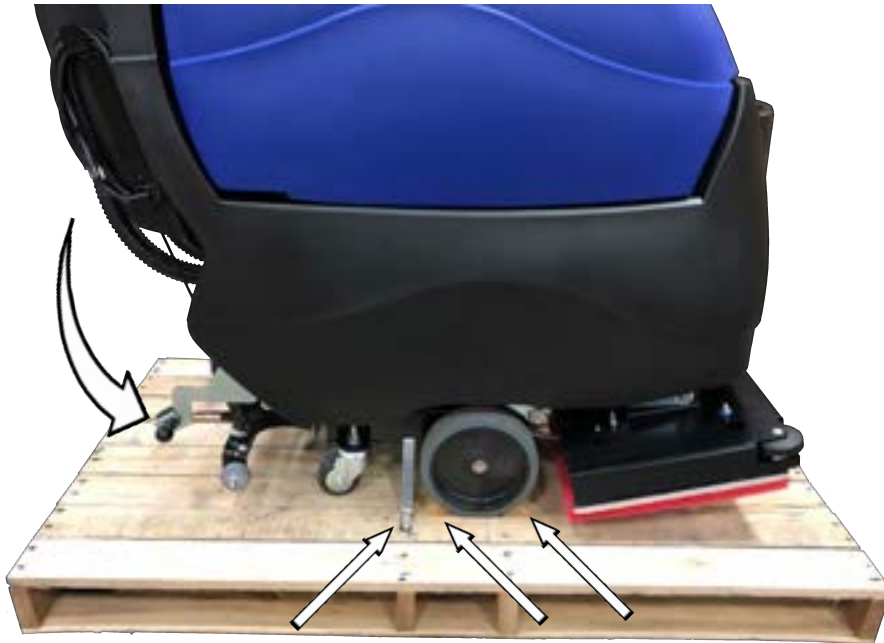

TRANSPORTING THE MACHINE

CAUTION: Remove the batteries and use mechanical assistance to lift machine manually.

NOTE: Fully drain the Solution and Recovery tanks before loading.

NOTE: Ensure the ramp and truck/trailer are properly rated for the weight of the machine.

NOTE: Use a ramp with no more than a 12% incline to load and unload the machine.

NOTE: Transport the machine with the scrub head in the lowered position.

NOTE: Do not lower the Orbital Scrub Head without a pad installed. Doing so will damage the Mighty-Lok® face.

NOTE: Remove and store the rear squeegee assembly before transporting the machine.



Two (2) tie-down points have been provided to allow the machine to be secured during transportation.

Ensure the machine is properly secured with suitable tie-down straps before transporting the machine.

BATTERIES

WARNING: Battery posts, terminals, and related accessories contain lead and lead compounds, chemicals known to the State of California to cause cancer and reproductive harm, and during charging, strong inorganic acid mists containing sulfuric acid are involved, a chemical known to the State of California to cause cancer. Wash hands after handling. For more information go to www.P65Warnings.ca.gov.

WARNING: Batteries emit hydrogen and oxygen gas.



- Keep sparks and open flame away.
- Do not smoke near the machine
- Charge batteries in a well-ventilated area with the battery compartment open

WARNING: Do not wear jewelry when working near moving or electrical components.



CAUTION: Park and service the machine on a level surface and remove the key.

CAUTION: Always wear protective clothing, gloves and goggles when handling and charging batteries.

NOTE: All repairs must be performed by a qualified service technician using approved replacement parts.

NOTE: Failure to clean the BatteryShield® light pipe will limit the system's ability to read the water level and will reduce battery life.

NOTE: Batteries designed for automotive or marine and RV use are not suited for use in floor scrubbers.

SELECTION

The machine requires two 12 VDC Lead Acid or AGM Deep Cycle batteries designed for floor scrubber use with the following maximum dimensions:

- Width: 7 1/8 in (181 mm)
- Length: 12 15/16 in (264 mm)
- Height: 10 5/8 in (295 mm)

INSTALLATION

1. Open the Recovery Tank.
2. Use a lifting device capable of lifting and transporting the batteries safely.
3. Move the batteries into position (as shown below).
4. Connect the batteries in a series to obtain an overall voltage of 24V.
5. Fully charge the batteries before use.

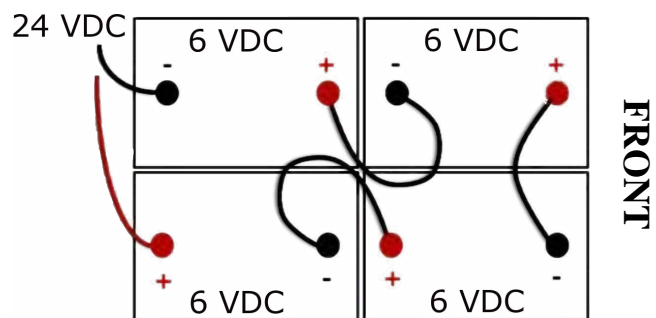
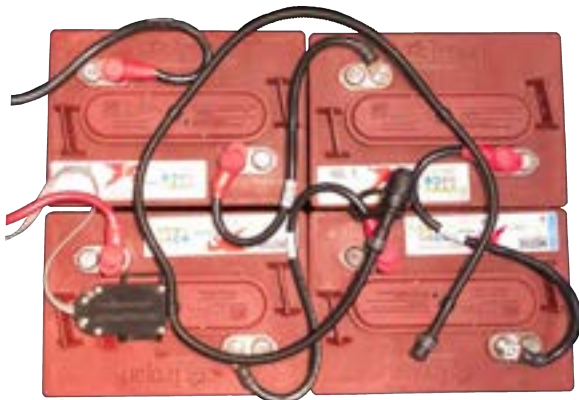

SERVICING LEAD ACID BATTERIES (NON-HYDROLINK® MODELS)

REQUIRED EQUIPMENT

- Eye protection
- Acid resistant gloves
- Distilled water
- Baking soda to neutralize acid spills

SAFETY

NEVER:

- Add acid to a battery.
- Smoke near batteries.
- Charge a frozen battery.
- Leave an acid spill unattended.
- Store batteries unless they are fully charged.
- Charge a battery when the temperature is above 122°F (50°C).
- Charge a flooded battery without securing vent caps on the cells.
- Place objects on top of batteries, which can cause a short circuit.

ALWAYS:

- Neutralize acid spills with baking soda and water.
- Use insulated tools to verify connections are tight.

WATERING

- If contact with electrolyte (sulfuric acid) occurs, flush with large amounts of water.
- Use only distilled water (tap water can contain contaminants that will damage the battery).
- Remove the caps and place them upside down to check electrolyte levels.
- For discharged or partially charged batteries, add just enough water to cover the plates.
- Fully charge the batteries.
- Add distilled water to a level of 1/8" (0.125") below the vent well.



CLEANING & INSPECTION

- Fluid on the top of a battery may mean it is being over-watered or overcharged.
- Check cleanliness and keep terminals and connectors free of corrosion.
- Clean with a solution of one cup baking soda to one gallon of water.
- Do not allow cleaning solution to get inside the battery.
- Rinse with water and dry with a clean cloth.
- Keep the area around batteries clean and dry.
- Properly secure all vent caps.
- Check battery cables and connections. Replace any damaged cables and tighten any loose connections.

SERVICING LEAD ACID BATTERIES WITH HYDROLINK® WATERING SYSTEM

WARNING: Battery posts, terminals, and related accessories contain lead and lead compounds, chemicals known to the State of California to cause cancer and reproductive harm, and during charging, strong inorganic acid mists containing sulfuric acid are involved, a chemical known to the State of California to cause cancer. Wash hands after handling. For more information go to www.P65Warnings.ca.gov.



1. Position the container of distilled water below the level of the top of the batteries to prevent siphoning.
2. Place the end of the watering system hose in the distilled water and squeeze the bulb to fill the system.
3. Remove the dust cover from the Hydrolink® snake connected to the batteries.
4. Connect the coupler on the Hydrolink® snake to the coupler on the watering system using the quick disconnect fittings.
5. While squeezing the hand pump, observe the flow indicator (spinning red balls). As the batteries begin to fill, the spinning of the flow indicator balls will slow. Batteries are full when the flow indicators completely stop spinning.

NOTE: Battery systems may take more than 1/2 gallon of water once the BatteryShield® light has illuminated. Failure to actuate the hand pump until the flow indicator stops spinning will result in batteries being under or unevenly serviced which will reduce battery life.

6. When the flow indicator stops, and not before, immediately disconnect the couplers by depressing the push button on the watering system coupler.

NOTE: Leaving the watering system connected could result in the batteries being over filled. Disconnecting the watering system before the flow indicator stops spinning will result in batteries being under serviced and battery life will be reduced.

7. Replace the dust cover on the Hydrolink® snake.

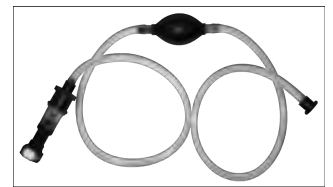

BATTERYSHIELD® AUTOMATED WET BATTERY PROTECTION SYSTEM

Machines equipped with BatteryShield® technology have a sensor installed on one of the battery caps and a red LED indicator located on the Control Panel. This sensor monitors the water level in the batteries and the LED communicates to the operator that the batteries require servicing. When the BatteryShield® LED is lit, the scrub head is disabled until battery servicing has been performed.



- When the key switch is turned on, the BatteryShield® system will check the water level of the batteries.
 - If the LED turns off, there is sufficient water in the batteries.
 - If the LED remains on (without flashing), the batteries require servicing and the scrub head will not run.
 - If the LED flashes intermittently, the BatteryShield® light pipe must be cleaned (instructions below).

NOTE: Failure to clean the BatteryShield® light pipe will limit the system's ability to read the water level and will reduce battery life.

- If the BatteryShield® LED indicates the need for servicing, turn off the key switch and service the batteries as described above.
- After completing the Hydrolink® watering system procedure, turn the key switch back on and verify the LED turns off.

CLEANING THE BATTERYSHIELD® SENSOR LIGHT PIPE

CAUTION: Always wear protective clothing, gloves and goggles when handling and charging batteries.

NOTE: All repairs must be performed by a qualified service technician using approved replacement parts.

1. Locate and remove the battery cap with the BatteryShield® sensor module.

NOTE: Never remove the BatteryShield® sensor from the battery cap. Doing so will cause the BatteryShield® system to function improperly.

NOTE: Take care not to damage the battery cap floats or the BatteryShield® sensor light pipe.

2. Thoroughly wipe the clear BatteryShield® light pipe with a clean rag, giving special attention to the tip.
3. With the battery cap still removed, cycle the key switch on to verify that the BatteryShield® LED remains on.
4. Turn off the key switch.
5. Carefully install the battery cap.

NOTE: Whenever the battery cap is removed, ensure the Hydrolink® snake port is fully seated in the cap when maintenance is complete.

6. Complete the Hydrolink® watering procedure described above.
7. Turn on the key switch and verify the light remains off.
8. The machine is ready for use.

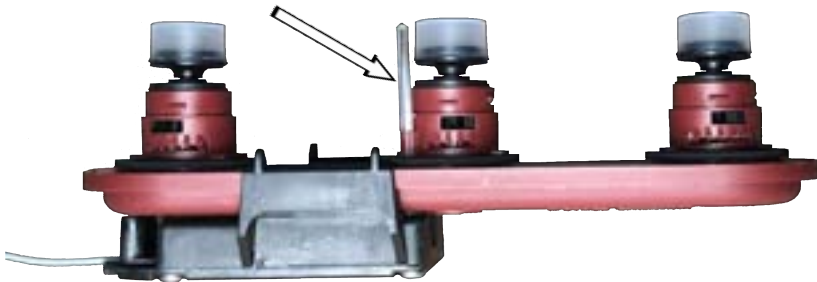

CHARGING

WARNING: Batteries emit hydrogen and oxygen gas.



- Keep sparks and open flame away.
- Do not smoke near the machine.
- Charge batteries in a well-ventilated area with the battery compartment open.

WARNING: Do not wear jewelry when working near moving or electrical components.



WARNING: Do not plug in the charger cable if wall cord or battery harness is damaged.



NOTE: Do not use an extension cord with the battery charger. This will void the charger warranty.

NOTE: Ensure battery charging and storage locations comply with OSHA and any governing agencies' standards based on your particular location and application.

NOTE: Seat assembly must remain open while charging to prevent damage to the charger power cord.

ON-BOARD CHARGING

The charger status LED's (used to indicate the charger's status while plugged in) can be viewed through the view window located on the vertical kick panel below the seat.

LED INDICATION	MEANING
GREEN flashing (2 seconds)	Charger is set for AGM batteries
YELLOW flashing (continuous)	Unsuitable battery connected or output short circuit
RED flashing (2 seconds)	Charger is set for Lead Acid batteries
RED flashing (continuous)	Safety timer exceeded or internal short circuit
Solid GREEN	The unit is fully charged
Solid YELLOW	Phase 2 of charging is in progress
Solid RED	Charging cycle has begun

CHARGER SETTINGS

SW1: Sets the current profile of the charger to the particular battery that is installed.

SW1		
DP2	DP1	APPLICATION
OFF	ON	LEAD-ACID BATTERIES
OFF	OFF	AGM FULLRIVER
ON	OFF	AGM DISCOVERY
ON	ON	GEL

SW2: Set the current level of the charger based on the amp-hour rating for the particular batteries installed.

SW2		
DP2	DP1	CHARGING CURRENT
ON	ON	15A
ON	OFF	20A
OFF	ON	25A - XCF
OFF	OFF	25A

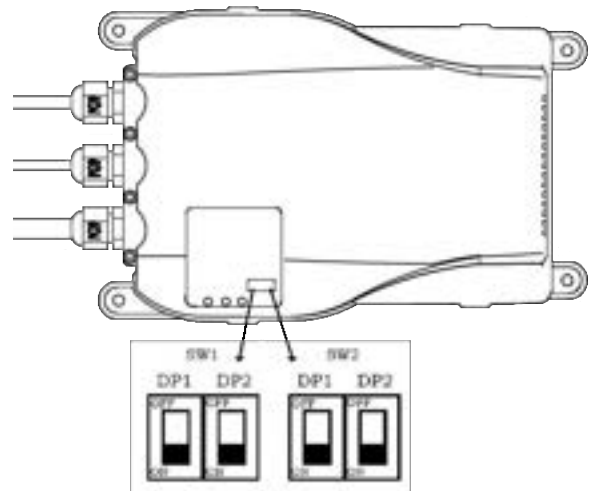

CHARGING CURRENT	BATTERY AMP HOUR RANGE (5h)	BATTERY AMP HOUR RANGE (20h)
15A	100-150 Ah	130-180 Ah
20A	120-195 Ah	150-240 Ah
25A	180-258 Ah	220-315 Ah

RETURN TO
TABLE OF
CONTENTS

OFF-BOARD CHARGER

WARNING: This product can expose you to chemicals including lead and lead compounds which are known to the State of California to cause cancer and birth defects or other reproductive harm. For more information go to www.P65Warnings.ca.gov.



WARNING: Batteries emit hydrogen and oxygen gas.



- Keep sparks and open flame away.
- Do not smoke near the machine.
- Charge batteries in a well-ventilated area with the battery compartment open.

WARNING: Do not plug in the charger cable if wall cord or battery harness is damaged.



NOTE: Ensure battery charging and storage locations comply with OSHA and any governing agencies' standards based on your particular location and application.

Set the **Battery Type** switch to match the battery configuration of the machine.

- Up for Lead Acid batteries.
 - Down for sealed, maintenance-free AGM batteries
1. Connect the charger to the wall outlet.
 2. Connect the red plug (pictured below) to the battery harness below the control panel at the rear of the machine.

Off-board status LEDs:

- Primary (green) LED:
 - Blinking slowly: Batteries are below 80% of full charge.
 - Blinking rapidly: Batteries are above 80% of full charge.
 - Solid: Batteries are fully charged.
- Fault (red) LED:
 - See the charger manual for fault information.

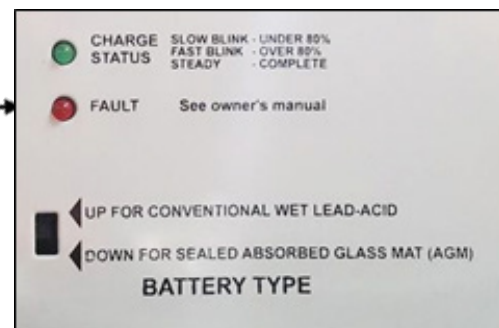
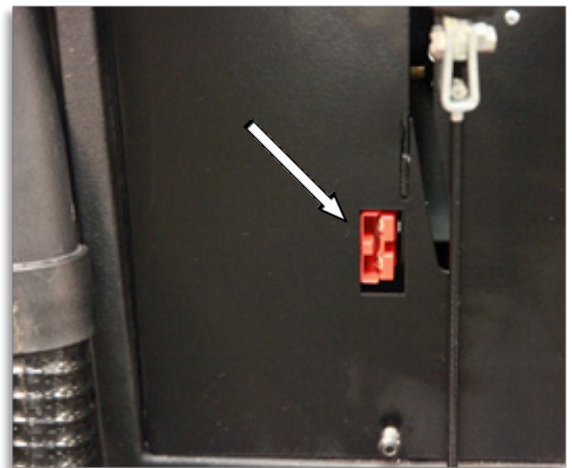

OPERATION MACHINE OVERVIEW

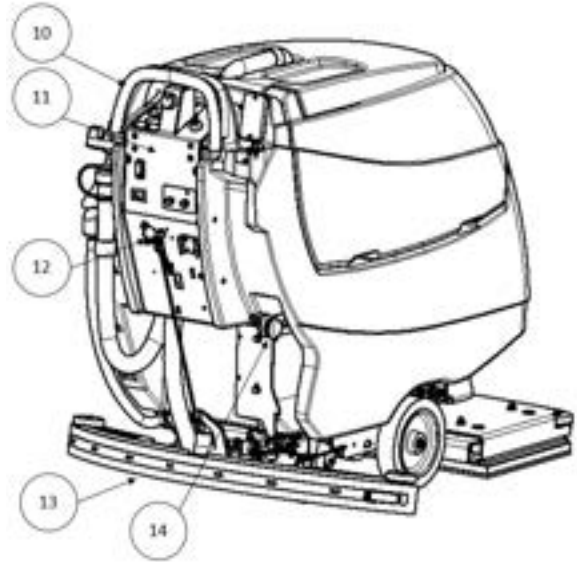

- 1. SCRUB HEAD
- 2. SOLUTION TANK
- 3. FILL PORT
- 4. RECOVERY TANK
- 5. RECOVERY TANK LID

- 6. RECOVERY HOSE
- 7. REVERSE SWITCH
- 8. RECOVERY DRAIN HOSE
- 9. SOLUTION SIGHT TUBE

- 10. DRIVE BAIL
- 11. CONTROL PANEL
- 12. SQUEEGEE LIFT LEVER
- 13. SQUEEGEE ASSEMBLY
- 14. HEAD LIFT LEVER

CONTROL PANEL



- A. CIRCUIT BREAKERS
- B. A/B SWITCH (DISK MODELS ONLY)
- C. BATTERYSHIELD LED (OPTIONAL)
- D. BATTERY LEVEL INDICATOR
- E. SOLUTION FLOW CONTROL

- F. DRIVE BAIL
- G. SPEED CONTROL
- H. KEY SWITCH
- I. HOUR METER (OPTIONAL)

RETURN TO
TABLE OF
CONTENTS

PRE-USE SETUP

TURNING THE UNIT ON/OFF

The key switch is located on the control panel. When the machine is not in use, remove the key and store it in a secure location.

CIRCUIT BREAKERS

The circuit breakers on the control panel protect the components from high amp-draw. In particular, the scrub head circuit will draw too many amps when overloaded by improper application setup. Solution flow, floor surface, and down-pressure should be considered when operating the machine (example: high down-pressure on a rough floor with no solution flow will overload the circuit). Repeatedly tripping the breaker will cause the need for replacement.

BATTERY POWER LEVEL & FAULT INDICATOR

When switched to the ON position, the Battery Power Level Indicator illuminates indicating the battery charge level. A full charge is indicated when all LEDs are lit. As the power level decreases, the LEDs go out from right to left.

When the battery charge is depleted, the last red LED will flash and the brush motor will turn off. The vacuum and traction drive will continue to function allowing final water recovery and transport to the charging station.

NOTE: Using AGM battery-equipped units after the last yellow LED goes out can reduce the life of the batteries.

NOTE: After a full charge, operate the machine for at least 30 minutes before recharging the batteries again. Do not leave the batteries discharged overnight.

A flashing **Battery Power Level Indicator** indicates a detected fault. The following is a list of fault codes:

1 Bar

 The battery needs to be charged or there is a faulty connection to the battery.

2 Bar

 Check the connection to the motor.

3 Bar

 The motor has a short circuit.

6 Bar

 The controller is being inhibited from driving.

7 Bar

 Throttle fault, check the connection.

8 Bar

 Controller fault, check connections

9 Bar

 Parking brake fault, check the motor connections.

10 Bar

 Excessive voltage, check the battery connections.

DRIVE SYSTEM

DRIVING OPERATION

1. Turn the machine on using the key switch located on the right side of the steering column.
2. Set the desired maximum speed using the Speed Control selector on the Control Panel.
3. Maintain control of the machine at all times during operation.
4. Depress the Bail to engage the scrub head and drive system.
5. Depress the Reverse Button to drive the machine backwards.

OPTIONAL SCRUBSMART TELEMETRY SYSTEM

The 22-gallon autoscrubber can be ordered with our ScrubSmart telemetry system, powered by Trackunit®. This system is used for asset tracking and reporting. For more information on this system and its reporting capabilities, contact your distributor or Pacific Floorcare Customer Service.

Telemetry-equipped machines have a keypad mounted on the upper right side of the control panel. After turning on the key switch, enter the operator code. **Failure to enter a valid operator code will prevent the machine from functioning.** Operator codes are generated and administered by your Pacific Distributor or your company's management.



SOLUTION DISTRIBUTION

FILLING THE SOLUTION TANK

Use liquid detergent in the concentration and manner specified by the manufacturer for a 22-gallon solution tank. Excess foam will damage the vacuum motor. In addition to properly-mixed low-foam detergent, use a small amount of de-foaming liquid in the recovery tank. Never use pure acids.

NOTE: The front fill port strainer blocks debris from falling into the tank. Keep the solution tank free from debris to prevent filter clogs and reduced solution flow.

1. Add water and cleaning agent via the front or rear fill port. Water temperature should not exceed 120°F (50°C).
2. Monitor the solution level through the sight tube and the marks on the tank at the rear of the machine.
3. To drain the tank, slide the solution sight tube off of the upper fitting and lower to a drain or mop sink.



SOLUTION FLOW: NON-CHEMICAL INJECTION MODELS

The Solution Control Knob is located on the top left corner of the control panel. The valve electrically turns on and off with the Scrub Head. The knob controls how much solution passes through the valve when activated.



OPTIONAL CHEMICAL INJECTION MODELS

1. Place a 1-gallon chemical container in the holder in the battery compartment and remove the cap.
2. Insert the leader hose so that the end is resting on the bottom of the container and screw on the cap.



3. Match the mix ration dial on the control panel to the setting (in ounces per gallon) prescribed on the chemical's container.
4. Set the solution flow rate to low, medium, or high.
5. A solid green LED indicates that the system is automatically mixing the chemical while the machine operates.

NOTE: If the detergent is not priming, temporarily select a higher setting until detergent appears on the floor.

NOTE: To purge old detergent, set the mixture dial to the highest ration and run until the leader hose line is empty.

INSPECTION & CLEANING

NOTE: If excessive debris is present, drain and flush the solution tank.

1. Close the shutoff valve.
2. Remove the filter bowl and screen.
3. Clean and rinse any debris in the filter assembly.



SCRUB DECK SETUP

HEAD LIFT

1. Depress the foot lever (located at the lower right rear corner of the machine) and shift it to the right.
2. Once clear of the notch, allow the lever to rise while the head lowers into the operating position.
3. Disk machines are equipped with a self-adjusting shroud and bristle skirt that virtually eliminates over-spray.

SELECTING DOWN PRESSURE

- Standard: For daily cleaning of normal soils and PAC pad and chemical processes.
- Heavy: For toughest soils or chemical-free finish removal.



Scrub Head Raised



Scrub Head Lowered



Heavy Down Pressure



Maximum Down Pressure

SCRUB HEAD DOWN PRESSURE			
	24" DISK	28" ORBITAL	28" & 32" DISK
STANDARD	50 lbs (23kgs)	70 lbs (32 kgs)	70 lbs (32 kgs)
MEDIUM	100 lbs (45 kgs)	110 lbs (50 kgs)	110 lbs (50 kgs)
HEAVY	140 lbs (64 kg)	160 lbs (73 kgs)	150 lbs (68 kgs)

ORBITAL PADS & CHEMICAL-FREE FINISH REMOVAL (CFR)

NOTE: Do not operate the Orbital Scrub Head without a pad installed. Operating the head without a pad will damage the Mighty-Lok® face.

STANDARD OPERATION

1. Align the corners of the pad to the corners of the aluminum plate with Mighty-Lok® face and press to attach.
2. Lower the scrub deck onto the pad.
3. Ensure the pad is properly aligned front-to-back and right-to-left. Water should drip directly onto the top of the pad.



CHEMICAL-FREE FINISH REMOVAL (CFR) PAD ASSEMBLY & OPERATION

In addition to the traditional cleaning pad, a specialized surface preparation pad is required for chemical-free finish removal. The standard red scrub pad acts as a “backer” and compensates for variances in the floor.

1. Place the black retainer pad 2” back from the front of the red scrub pad.
2. Align the maroon CFR pad with the red scrub pad.
3. Ensure the pads are aligned so that the black pad is justified towards the back of the machine, so that the gap described in Step 1 is towards the front of the machine.
4. Install the pads in accordance with the instructions above for standard operation.
5. Fill the Solution Tank with clean water.
6. Set the Solution Flow to the medium setting. Adjust as needed to obtain the optimum finish removal using the least amount of water for effective rinsing.
7. Set the Speed Control to the medium setting.
8. Lower the Scrub Head to the Heavy Down Pressure setting.

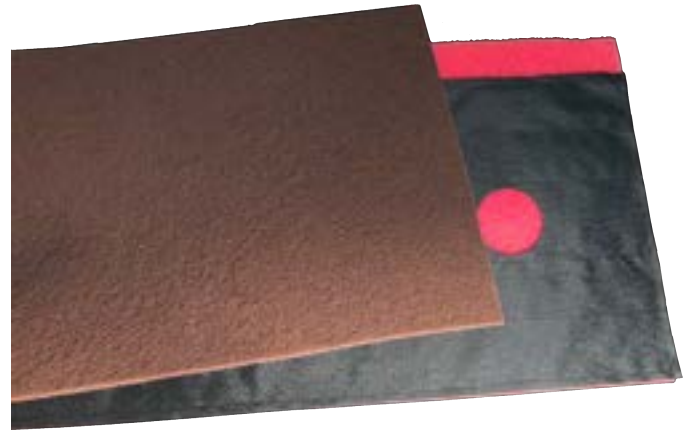

DISK MACHINE PAD DRIVERS & BRUSHES

PAD & BRUSH INSTALLATION

NOTE: Do not operate the Disk Scrub Head without a pad installed on the pad driver. Operating the head without a pad will damage the floor.

1. Turn the key switch on and rotate the speed control knob to the full slow position.
2. Place the pad drivers or brushes on the floor in front of the scrub head.
3. Push or drive the machine into position centering the scrub head over the pad drivers or brushes.
4. Lower the scrub deck onto the pad drivers or brushes.

NOTE: When properly aligned, the scrub deck shroud bristle skirt should almost be touching the floor.

5. Quickly squeeze and release the Bail to engage the pad driver or brushes.

NOTE: If the pad drivers or brushes do not quickly engage, return to step two and try again.



PAD & BRUSH REMOVAL

1. Toggle the “Brush On/Off” switch to position “A” for 1 second and then immediately to position “B”. The brush will spin in position “A” and abruptly stop in position “B”, releasing the pad drivers.
2. Remove the center lock fitting by squeezing the wires inward and pulling the center lock away.
3. To connect the cleaning pad to the drivers, center the pad on the driver, squeeze the center lock wires inward, and press down (tab side first). Press the pad and release the wires so that they lock in place.

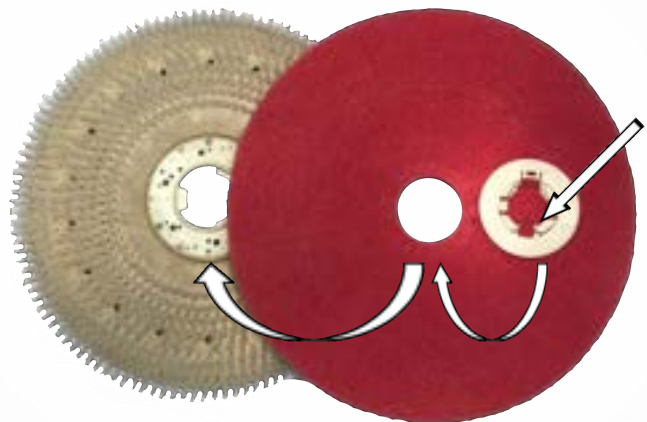

RECOVERY SYSTEM

RECOVERY TANK

To drain and rinse the recovery tank:

1. Lift the hose off the holder and lower the hose end to the desired drain location.
2. Remove the press-fit cap from the drain hose and squeeze the restriction collar to control the flow.
3. As the tank drains, lift the recovery tank lid to the fully open position.
4. Thoroughly clean and rinse out the sediment from the bottom of the tank with a clean water hose.
 - Periodically use cleaner and sanitizer with a cloth or sponge to prevent mold and mildew.
5. Inspect and clean the debris tray and the vacuum mesh filter screen and ball float system.
6. Leave the lid open to dry

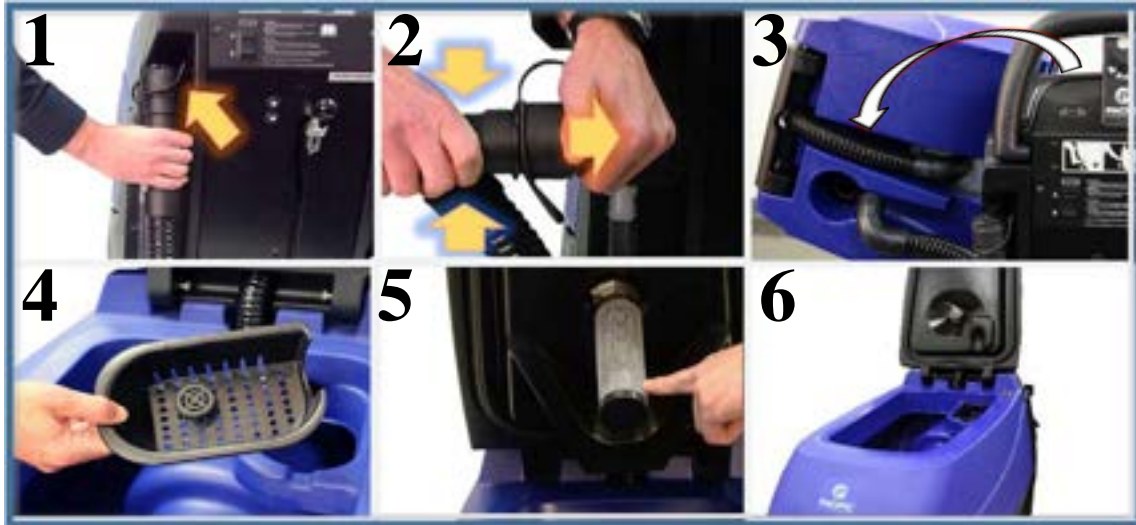

OPTIONAL TANK TREATMENT

The Tank Treatment System (TTS) utilizes Bromine tablets (typically used in pools and spas) to kill the odor-causing bacteria in the tank. To ensure that the TTS is prepared to treat your recovery tank:

1. Lift the debris tray out and pinch the two tabs sticking through the underside of the tray.
2. Check the size of the Bromine puck. Replace it when it is approximately 25% of its original size.
3. Press the TTS holder and bromine puck back into the debris tray.

CAUTION: Use Bromine only! Do not use chlorine! Chlorine can interact with ammonia-based detergents to cause harmful fumes.



SQUEEGEE SYSTEM

Squeegee Blades and system should be inspected and maintained regularly to achieve peak machine performance.

REMOVAL & INSTALLATION

Install: Align the slots in the squeegee assembly with the easy-grip knobs, attach the vacuum hose, and tighten the knobs.

Remove: Loosen the easy-grip knobs, remove the vacuum hose, and remove the assembly.



SQUEEGEE USE

With the Key Switch turned on, lower the Squeegee Lift Lever to activate the Vacuum Motor. Raising the Squeegee Lift Lever will deactivate the Vacuum Motor to shut off after a 10 second delay. This delay ensures all of the recovered water is pulled into the Recovery Tank.



SQUEEGEE ADJUSTMENT

Improper adjustment of the squeegee blades will reduce the systems ability to properly pick up water. The leading edge of the rear squeegee blade should contact the floor at a 45° angle (similar to the image shown below). The height of the squeegee system is adjusted using the two cap head screws located next to the easy-grip knobs. Raise (by turning the screws clockwise) or lower (by turning the screws counter-clockwise) until the proper blade deflection is achieved. When the system is adjusted properly, the small gray wheels on the squeegee system should be approximately 1/32" off of the floor.

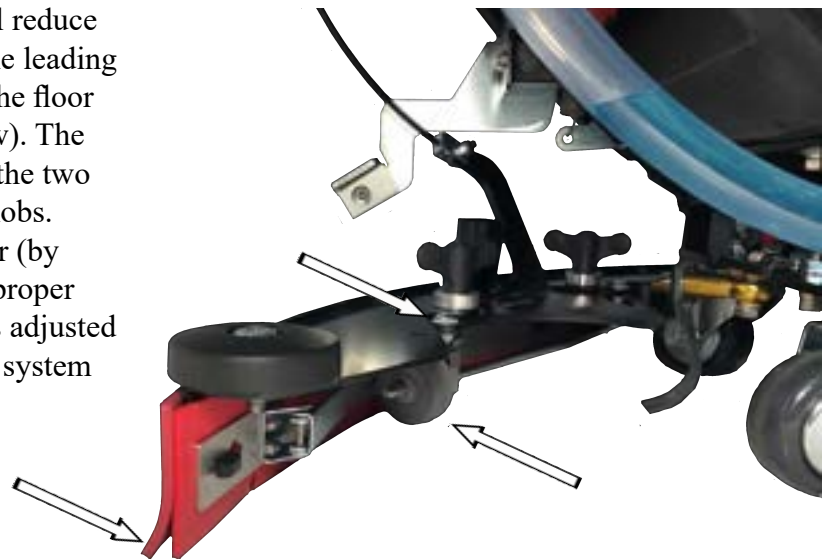

INSPECTION & CLEANING

1. Inspect both squeegee blades. Blades edges are considered worn if the edge is not clearly defined or if the edge is worn halfway through the thickness of the blade. Blades can be flipped and rotated to use all four edges.
2. Thoroughly clean the blades, frame, and neck of any debris.



SQUEEGEE BLADE REPLACEMENT

1. Release the over-center latch and slide the band clamp off the hook on the other side.
NOTE: Blades can be flipped and rotated so as to use all four edges.
2. Blade installation is the reverse of the removal.



RECOMMENDED MAINTENANCE

SYSTEM	REFERENCE SECTION	DAILY	WEEKLY	MONTHLY	BIANNUALLY
CONTROL PANEL					
INSPECT ALL CONTROLS AND HARDWARE FOR SECURITY AND SERVICEABILITY	PARTS DIAGRAMS	X			
VERIFY PROPER OPERATION OF ALL CONTROLS	ALL	X			
SOLUTION DISTRIBUTION					
VERIFY SOLUTION FLOWS AND ADJUSTS AS EXPECTED	SOLUTION DISTRIBUTION	X			
CLEAN AND INSPECT IN-LINE FILTER	SOLUTION DISTRIBUTION			X	
FLUSH TANK WITH FRESH WATER	SOLUTION DISTRIBUTION			X	
SCRUB DECK					
RINSE BRUSHES & PADS	SCRUB DECK SETUP	X			
RINSE & DRY SCRUB DECK	SCRUB DECK SETUP	X			
CLEAN MOTOR VENTS	PARTS DIAGRAMS			X	
INSPECT ISOLATORS *(ORBITAL ONLY)	PARTS DIAGRAMS				X
INSPECT LIFT LINKAGE & PIVOT BLOCKS	SCRUB DECK SETUP				X
RECOVERY SYSTEM					
RINSE & AIR DRY RECOVERY TANK	RECOVERY SYSTEM	X			
CLEAN & INSPECT DEBRIS TRAY	RECOVERY SYSTEM	X			
VERIFY DRAIN HOSE CAP IS SEALED TIGHT WHEN INSTALLED	RECOVERY SYSTEM	X			
INSPECT LID SEAL	RECOVERY SYSTEM		X		
INSPECT / REPLACE BROMINE PUCK *(IF EQUIPPED)	RECOVERY SYSTEM		X		
INSPECT HEPA FILTER *(IF EQUIPPED)	RECOVERY SYSTEM				X
CLEAN & SANITIZE RECOVERY TANK	RECOVERY SYSTEM			X	
BATTERIES AND CHARGER					
INSPECT TERMINALS & CABLES FOR SECURITY, CORROSION, OR DAMAGE	BATTERIES			X	
SERVICE LEAD ACID BATTERIES *(IF EQUIPPED)	BATTERIES		X		
CLEAN ONBOARD CHARGER VENTS *(IF EQUIPPED)	PARTS DIAGRAMS			X	
CLEAN BATTERYSHIELD* LIGHT PIPE *(IF EQUIPPED)	BATTERIES				X
PERFORM BATTERYSHIELD* OPERATIONAL CHECKS *(IF EQUIPPED)	BATTERIES				X
SQUEEGEE ASSEMBLY					
CLEAN & INSPECT SQUEEGEE ASSEMBLY & BLADES	RECOVERY SYSTEM	X			
INSPECT VACUUM HOSE	RECOVERY SYSTEM		X		
CHASSIS AND UNDERCARRIAGE					
CLEAN & INSPECT WHEELS & CASTERS	PARTS DIAGRAMS			X	
CLEAN & INSPECT LINKAGES, CHASSIS & HARDWARE	PARTS DIAGRAMS			X	
CLEAN & INSPECT VISIBLE WIRES FOR DAMAGE & SECURITY	PARTS DIAGRAMS				X

RECOMMENDED SERVICE PARTS

(PAGE 1 OF 3)

PART NUMBER	DESCRIPTION	DIAGRAM CATEGORY	WEAR ITEM	S-24	S-28 DISK	S-32	S-28 ORB	OPTIONAL
903046	BELT, V-GROOVE, STRETCH	SCRUB HEAD	X	X				
870702	BLADE, FRONT, 35INCH (LINATEX)	SQUEEGEE	X	X				
870708	BLADE, FRONT, 35INCH (URETHANE)	SQUEEGEE	X	X				
870704	BLADE, FRONT, 40INCH (LINATEX)	SQUEEGEE	X		X		X	
870710	BLADE, FRONT, 40INCH (URETHANE)	SQUEEGEE	X		X		X	
870706	BLADE, FRONT, 44.5INCH (LINATEX)	SQUEEGEE LINK	X	X	X	X	X	
870712	BLADE, FRONT, 44.5INCH (URETHANE)	SQUEEGEE LINK	X	X	X	X	X	
870701	BLADE, REAR, 35INCH (LINATEX)	SQUEEGEE	X	X				
870707	BLADE, REAR, 35INCH (URETHANE)	SQUEEGEE	X	X				
870703	BLADE, REAR, 40INCH (LINATEX)	SQUEEGEE	X		X		X	
870709	BLADE, REAR, 40INCH (URETHANE)	SQUEEGEE	X		X		X	
870705	BLADE, REAR, 44.5INCH (LINATEX)	SQUEEGEE LINK	X	X	X	X	X	
870711	BLADE, REAR, 44.5INCH (URETHANE)	SQUEEGEE LINK	X	X	X	X	X	
911681	BREAKER, CIRCUIT, 35 AMPS	CONTROLS			X	X		
850906	BRUSH CARBON KIT 4 PC 855204 & 875201	SCRUB HEAD	X	X	X	X	X	
870919	BRUSH KIT REPL FOR TRANSAXLE 879203	FRAME ASSEMBLY	X	X	X	X	X	
870909	BRUSH, GRIT, 12 INCH	SCRUB HEAD	X	X				
870906	BRUSH, GRIT, 14 INCH	SCRUB HEAD	X		X			
870907	BRUSH, GRIT, 16 INCH	SCRUB HEAD	X			X		
870908	BRUSH, NYLON, 12 INCH	SCRUB HEAD	X	X				
870904	BRUSH, NYLON, 14 INCH	SCRUB HEAD	X		X			
870905	BRUSH, NYLON, 16 INCH	SCRUB HEAD	X			X		
870902	BRUSH, POLY, 12 INCH	SCRUB HEAD	X	X				
870901	BRUSH, POLY, 14 INCH	SCRUB HEAD	X		X			
852401	CABLE, LIFT, CLEVIS	CONTROLS		X	X	X	X	
871501	CAP, 38MM, WITH HOLE	CHEMICAL INJECTION	X					X
911622	CIRCUIT BREAKER, 30 AMPS	CONTROLS		X	X	X	X	
912401	CONTACTOR, 24V, 100A	ELECTRONICS		X	X	X	X	
912402	CONTACTOR, 24VDC, 70A	ELECTRONICS		X	X	X	X	
875902	DRIVER, PAD, 14 INCH	SCRUB HEAD	X		X			

RECOMMENDED SERVICE PARTS

(PAGE 2 OF 3)

PART NUMBER	DESCRIPTION	DIAGRAM CATEGORY	WEAR ITEM	S-24	S-28 DISK	S-32	S-28 ORB	OPTIONAL
875910	DRIVER, PAD, 16 INCH	SCRUB HEAD	X			X		
873304	FILTER, HEPA, MID	RECOVERY TANK	X	X	X	X	X	
843319	FILTER, SCREEN, BOWL	FRAME ASSEMBLY	X	X	X	X	X	
S764P2	FILTER, STRAINER	CHEMICAL INJECTION	X					X
223370	FLOAT, SHUTOFF	RECOVERY TANK		X	X	X	X	
873314	GASKET, FOAM, VACUUM	RECOVERY TANK		X	X	X	X	
853803	GUIDE, DRIVER	SCRUB HEAD	X	X	X	X		
873802	GUIDE, DRIVER, RH	SCRUB HEAD	X	X	X	X		
853804	GUIDE, PAD, PLASTIC	SCRUB HEAD	X		X	X		
873801	GUIDE, PAD, PLASTIC	SCRUB HEAD	X	X				
854101	HOSE, DRAIN, CAPPED	RECOVERY TANK	X	X	X	X	X	
874101	HOSE, SQUEEGEE, 90 CUFF	RECOVERY TANK	X	X	X	X	X	
854103	HOSE, VACUUM, 1.5INCH	RECOVERY TANK		X	X	X	X	
854302	HUB, DRIVER, BRUSH	SCRUB HEAD	X		X	X		
874305	HUB, PULLEY, MACH FLAT	SCRUB HEAD	X	X				
874306	HUB, PULLEY, MACH GROOVED	SCRUB HEAD	X	X				
875017	KIT CASTER 4 INCH REPLACEMENT	FRAME ASSEMBLY	X	X	X	X	X	
875010	KIT, BEARING, REPL, ORBIT	SCRUB HEAD	X				X	
875009	KIT, PLATE, REPL, ORBIT	SCRUB HEAD	X				X	
875202	MOTOR, VACUUM, 24VDC, 3-STAGE	RECOVERY TANK		X	X	X	X	
555901	PAD 12" BLACK STRIP CASE 5	SCRUB HEAD	X	X				
555941	PAD 12" RED SCRUB CASE 5	SCRUB HEAD	X	X				
555951	PAD 12" WHITE POLISH CASE 5	SCRUB HEAD	X	X				
555902	PAD 14" BLACK STRIP CASE 5	SCRUB HEAD	X		X			
555942	PAD 14" RED SCRUB CASE 5	SCRUB HEAD	X		X			
555952	PAD 14" WHITE POLISH CASE 5	SCRUB HEAD	X		X			
555909	PAD 14"X28" BLACK STRIP CASE 5	SCRUB HEAD	X			X		
555929	PAD 14"X28" MAROON CFR CASE 10	SCRUB HEAD	X			X		
555949	PAD 14"X28" RED SCRUB CASE 5	SCRUB HEAD	X			X		

RECOMMENDED SERVICE PARTS

(PAGE 3 OF 3)

PART NUMBER	DESCRIPTION	DIAGRAM CATEGORY	WEAR ITEM	S-24	S-28 DISK	S-32	S-28 ORB	OPTIONAL
555969	PAD 14"X28" TURF CASE 4	SCRUB HEAD	X			X		
555959	PAD 14"X28" WHITE POLISH CASE 5	SCRUB HEAD	X			X		
555903	PAD 16" BLACK STRIP CASE 5	SCRUB HEAD	X				X	
555943	PAD 16" RED SCRUB CASE 5	SCRUB HEAD	X				X	
555953	PAD 16" WHITE POLISH CASE 5	SCRUB HEAD	X				X	
875903	PAD, MIGHTYLOK ADH UNIVERSAL	SCRUB HEAD	X				X	
875906	PAD, RETAINER, 12X28	SCRUB HEAD	X				X	
857003	PUMP ASSY HAND HYDROLINK	BATTERIES	X					X
858503	SKIRT, BRISTLE	SCRUB HEAD	X	X				
878502	SKIRT, BRISTLE	SCRUB HEAD	X		X	X		
911647	SWITCH, KEY	CONTROLS		X	X	X	X	
911649	SWITCH, ROCKER, AUTO ON-OFF	CONTROLS		X	X	X		
911653	SWITCH, ROUND, ON - MOM	CONTROLS		X	X	X	X	
911682	SWITCH, SNAP, BENT LEVER	FRAME ASSEMBLY		X	X	X	X	
911646	SWITCH, SNAP, WITH ROLLER	CONTROLS		X	X	X	X	
879201	TRAY, DEBRIS	RECOVERY TANK	X	X	X	X	X	
879202	TRAY, PUCK	RECOVERY TANK	X	X	X	X	X	
855022	KIT-GUIDE WHEEL REPL, ANTI-RATTLE	SCRUB HEAD	X	X	X	X	X	
879705	WHEEL, URETHANE, 222MM	FRAME ASSEMBLY		X	X	X	X	

TROUBLESHOOTING GUIDE

(PAGE 1 OF 2)

ISSUE	POTENTIAL CAUSE	PROPOSED SOLUTION	MANUAL SECTION
INSUFFICIENT WATER TO SCRUB HEAD	SOLUTION FLOW SETTING IS TOO LOW	ADJUST SOLUTION CONTROL	SOLUTION DISTRIBUTION
	SOLUTION TANK IS EMPTY	ADD WATER/SOLUTION TO THE TANK	SOLUTION DISTRIBUTION
	IN-LINE SOLUTION FILTER IS CLOGGED	REMOVE AND CLEAN THE FILTER	SOLUTION DISTRIBUTION
	SOLUTION TUBE IS CLOGGED, KINKED, OR DAMAGED	INSPECT TUBES	PARTS DIAGRAMS
	SOLUTION SHUT OFF VALVE IS CLOSED	OPEN VALVE	SOLUTION DISTRIBUTION
	SOLUTION SOLENOID VALVE MAY BE FAULTY	VERIFY OPERATION AND REPLACE IF NECESSARY	PARTS DIAGRAMS
POOR WATER RECOVERY	RECOVERY TANK IS FULL	EMPTY RECOVERY TANK	RECOVERY SYSTEM
	DIRTY OR WORN SQUEEGEE BLADES	INSPECT AND ROTATE OR REPLACE AS REQUIRED	RECOVERY SYSTEM
	RECOVERY HOSE LOOSE OR DAMAGED	INSPECT AND REPAIR	PARTS DIAGRAMS
	RECOVERY HOSE OR SQUEEGEE ASSEMBLY HAS AN OBSTRUCTION	CLEAR OBSTRUCTIONS FROM RECOVERY SYSTEM	PARTS DIAGRAMS
	SQUEEGEE ASSEMBLY MAY BE OUT OF ADJUSTMENT	ADJUST AS NECESSARY	RECOVERY SYSTEM
	STUCK OR DAMAGED BALL FLOAT	INSPECT AND REPAIR/REPLACE	RECOVERY SYSTEM
	RECOVERY TANK LID IS NOT SEALING PROPERLY	INSPECT RECOVERY LID GASKET. REPAIR OR REPLACE IF NEEDED	PARTS DIAGRAM
	DRAIN HOSE CAP IS NOT INSTALLED PROPERLY	INSTALL DRAIN HOSE SECURELY	RECOVERY SYSTEM
	LOW BATTERY VOLTAGE	CHARGE BATTERIES	CHARGING
MACHINE WILL NOT TURN ON	FAULTY KEY SWITCH	DIAGNOSE AND REPLACE	WIRING DIAGRAMS
	DISCHARGED BATTERIES	CHARGE BATTERIES	CHARGING
	LOOSE OR DAMAGED WIRE	REPAIR	WIRING DIAGRAMS
MACHINE NOT CLEANING FLOOR PROPERLY	WORN PAD OR BRUSH	INSPECT AND REPLACE AS REQUIRED	SCRUB DECK SETUP
	WRONG PAD OR BRUSH FOR APPLICATION	CONTACT YOUR LOCAL DISTRIBUTOR FOR RECOMMENDED APPLICATION	SCRUB DECK SETUP
	INSUFFICIENT CLEANING SOLUTION FOR APPLICATION	ADJUST THE MIXTURE AS REQUIRED	SOLUTION DISTRIBUTION
EXCESSIVE FOAM IN RECOVERY TANK	IMPROPER DETERGENT TYPE	USE A LOW-FOAM DETERGENT OR ADD A DEFOAMING AGENT TO THE RECOVERY TANK. READ ALL CHEMICAL LABELS THOROUGHLY BEFORE USE	RECOVERY SYSTEM
	MIXTURE SETTING TOO HIGH ON OPTIONAL CHEMICAL INJECTION SYSTEM	USE A LOW-FOAM DETERGENT OR ADD A DEFOAMING AGENT TO THE RECOVERY TANK. READ ALL CHEMICAL LABELS THOROUGHLY BEFORE USE	RECOVERY SYSTEM
VACUUM MOTOR WILL NOT RUN	SQUEEGEE LIFT LEVER IS STILL RAISED	LOWER SQUEEGEE LEVER	RECOVERY SYSTEM
	VACUUM RELAY MAY BE FAULTY	CONTACT SERVICE TECHNICIAN TO TROUBLESHOOT AND ISOLATE	WIRING DIAGRAMS
	VACUUM SWITCH OR WIRING MAY BE FAULTY	CONTACT SERVICE TECHNICIAN TO TROUBLESHOOT AND ISOLATE	WIRING DIAGRAMS
VACUUM MOTOR WILL NOT TURN OFF	STILL IN DELAY MODE	ALLOW 10 SECONDS FOR VACUUM TO SHUT DOWN	RECOVERY SYSTEM
	VACUUM RELAY MAY BE FAULTY	CONTACT SERVICE TECHNICIAN TO TROUBLESHOOT AND ISOLATE	WIRING DIAGRAM

TROUBLESHOOTING GUIDE

(PAGE 2 OF 2)

ISSUE	POTENTIAL CAUSE	PROPOSED SOLUTION	MANUAL SECTION
SCRUB HEAD WILL NOT RUN	SCRUB HEAD IS STILL RAISED	LOWER SCRUB HEAD	SCRUB DECK SETUP
	BATTERYSHIELD® LED IS ILLUMINATED AND HAS DISABLED THE SCRUB HEAD (IF EQUIPPED)	SERVICE THE BATTERIES	BATTERIES
	BATTERIES ARE DISCHARGED BELOW THRESHOLD VOLTAGE	CHARGE BATTERIES	CHARGING
	BRUSH MOTOR CIRCUIT BREAKER HAS TRIPPED	SEE NEXT TOPIC ON THIS TABLE	TROUBLESHOOTING TABLE
	SCRUB HEAD LIFT ARM SWITCH MAY BE STUCK OR FAULTY	INSPECT AND REPAIR SWITCH AS REQUIRED	PARTS DIAGRAMS
	TRIGGER SWITCH IN HANDLE MAY BE FAULTY	INSPECT AND REPAIR AS REQUIRED	PARTS DIAGRAMS
	SOLUTION SOLENOID VALVE MAY HAVE AN INTERNAL SHORT	DISCONNECT WIRES FROM SOLENOID VALVE AND TRY RUNNING THE SCRUB HEAD AGAIN. REPLACE SOLENOID IF REQUIRED	WIRING DIAGRAM
	BATTERYSHIELD® RELAY MAY BE FAULTY (IF EQUIPPED)	CONTACT SERVICE TECHNICIAN TO TROUBLESHOOT AND ISOLATE	WIRING DIAGRAM
SCRUB HEAD CIRCUIT BREAKER IS TRIPPED	INADEQUATE SOLUTION FOR APPLICATION	INCREASE SOLUTION TO SCRUB HEAD	PRE-USE SETUP
	SCRUB HEAD IS SET TO HEAVY DOWN PRESSURE	REDUCE DOWN PRESSURE SETTING	PRE-USE SETUP
	PAD IS TOO AGGRESSIVE FOR APPLICATION	CONTACT YOUR LOCAL DISTRIBUTOR FOR RECOMMENDED APPLICATION	PRE-USE SETUP
	FAULTY OR SHORTED WIRE	REPAIR	WIRING DIAGRAM
	WEAK CIRCUIT BREAKER	CONTACT SERVICE TECHNICIAN TO TROUBLESHOOT AND ISOLATE. BREAKER SHOULD NOT TRIP BELOW ITS STATED RATING	PARTS DIAGRAMS
MACHINE WILL NOT DRIVE	CIRCUIT BREAKER MAY BE TRIPPED	INSPECT AND RESET. IF PROBLEM PERSISTS CONTACT SERVICE TECHNICIAN	PRE-USE SETUP
	BATTERY METER IS FLASHING A FAULT CODE	REFERENCE FAULT CODE AND TROUBLESHOOT AS REQUIRED	PRE-USE SETUP
	BATTERIES DISCHARGED TOO LOW	CHARGE BATTERIES	CHARGING
	SPEED CONTROL KNOB TURNED ALL THE WAY DOWN	INCREASE SPEED SETTING	DRIVE SYSTEM
	FAULTY CONTROLLER	CONTACT SERVICE TECHNICIAN TO TROUBLESHOOT AND ISOLATE	WIRING DIAGRAM
	FAULTY WIRING	CONTACT SERVICE TECHNICIAN TO TROUBLESHOOT AND ISOLATE	WIRING DIAGRAM
RUN TIME IS SHORT	BATTERIES ARE LOW ON WATER (LEAD ACID ONLY)	SERVICE BATTERIES	BATTERIES
	CHARGER IS NOT SET PROPERLY FOR BATTERY TYPE	SET CHARGER TO BATTERY SPECIFICATIONS	CHARGING
	SCRUB HEAD IS IN HEAVY DOWN PRESSURE	REDUCE SCRUB HEAD PRESSURE	PRE-USE SETUP
	BATTERY CHARGER IS NOT ABLE TO FINISH CHARGE CYCLE	CONFIRM A STEADY GREEN LED AFTER THE CHARGE CYCLE (BEFORE UNPLUGGING FROM THE OUTLET)	CHARGING
	BATTERIES ARE DEFECTIVE OR AT THE END OF THEIR LIFE	CONTACT SERVICE TECHNICIAN TO TROUBLESHOOT AND ISOLATE	BATTERIES

- 1 If the scrub head is not working when lowered, be aware that BatteryShield® intentionally disables the scrub head when the batteries need water. Refer to the BatteryShield® Automatic Wet Battery Protection System portion of this manual.
2. For machines equipped with BatteryShield®, refer to the BatteryShield® Automatic Wet Battery Protection System portion of this manual before proceeding.
3. If a yellow LED is flashing on the battery charger, verify continuity between the charger and the batteries. Refer to the On-Board Charger section of this manual.
4. A circuit breaker is designed to prevent overloading a component/system. If a circuit breaker continues to trip, verify the system is not being overloaded or that the wiring is not damage.

BATTERIES, BATTERYSHIELD® & HYDROLINK®

ITEM	QTY	PART NUMBER	DESCRIPTION
1*	4	871301	BATTERY, 6V, 260AH, LA
1*	4	871302	BATTERY, 6V, 250AH, MF (NOT SHOWN, OPTIONAL)
2	3	855605	MANIFOLD INDIV HYDROLINK (BATT CAP)
3	3	911640	HARNESS, CONN, BATTERY
4	1	878520	SENSOR ASSY BATTERYSHIELD FIELD REPLACE
5	1	858202	FOAM, SPACER, BATTERY
6	1	911641	HARNESS, CONN, BATTERY
7	1	857003	PUMP ASSY HAND HYDROLINK
8	1	879002	COMPLETE SETS MANIFOLDS (BATT CAP), SERVICE TUBE & PUMP

BATTERYSHIELD® SENSOR IS MATED AND CALIBRATED TO THE MANIFOLD (BATTERY CAP) FROM THE FACTORY. SENSOR AND CAP MUST BE REPLACED AS AN ASSEMBLY – **DO NOT REMOVE SENSOR FROM CAP**

*Item 1 is based on machine model.

**Items 2 & 4 not used with maintenance-free batteries or machines ordered without optional BatteryShield®.

***Item 8 not shown.

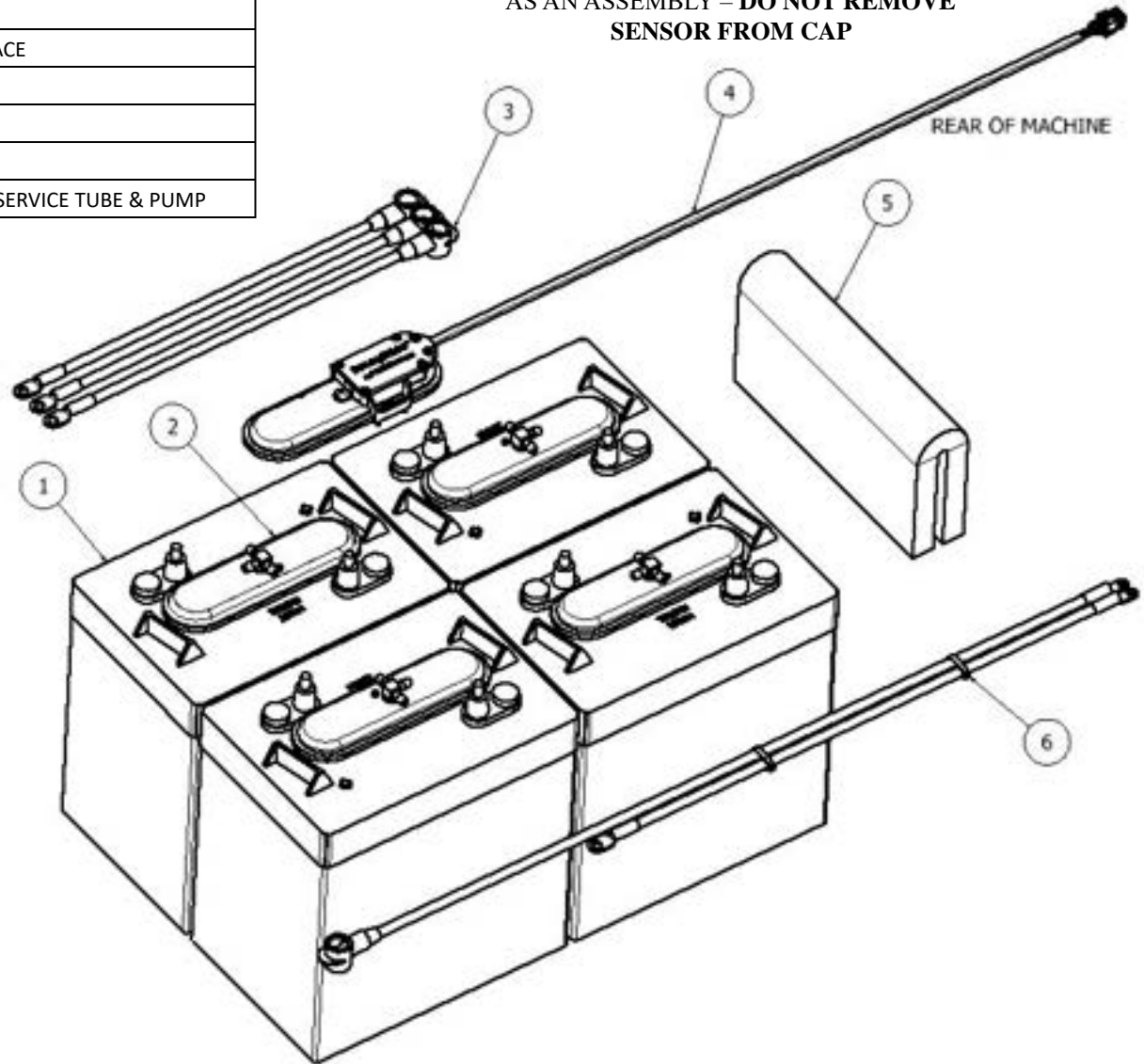

OPTIONAL ONBOARD CHARGER

ITEM	QTY	PART NUMBER	DESCRIPTION
1	1	852407	CHARGER, 24V, ONBRD, CULUS
2	1	911645	HARNESS, CHARGER, POST
3	1	870817	BRACKET, MTG, CHARGER
4	2	W189D	SCREW, HEX, 1/4-20 X .75, SS, PATCH
5	2	980002	WASHER, LOCK, SPLIT, .25
6	2	W104D	WASHER, FLAT, .25
7	4	962186	SCREW, PAN, #10-32 X 1.0, SS
8	1	W323D	SCREW, PAN, #6-32 X 1.0, ZINC
9	1	850805	BRACKET, MTG, CORD
10	2	962263	SCREW, BUTT, SOCK, .25-20X.62, SS BO
11	2	501210	BUMPER
12	1	920034	NUT, NYLOCK, #6-32, SS
13	6	W401D	WASHER, FLAT, #10
14	4	920666	NUT, NYLOCK, #10-32, SS

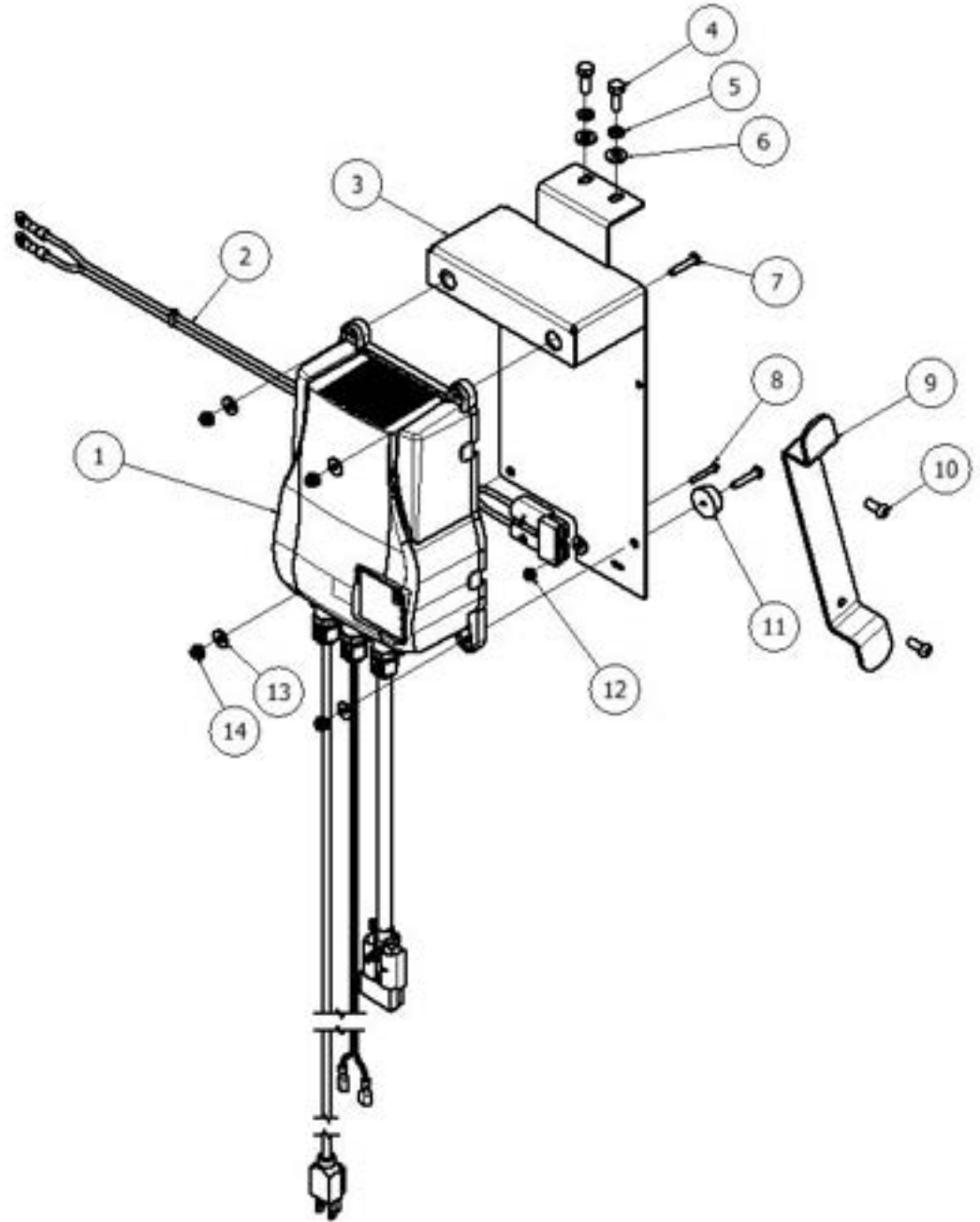

CONTROLS

S-24 DISK

(See additional diagrams for models equipped with BatteryShield®, chemical injection, or ScrubSmart® telemetry systems.)

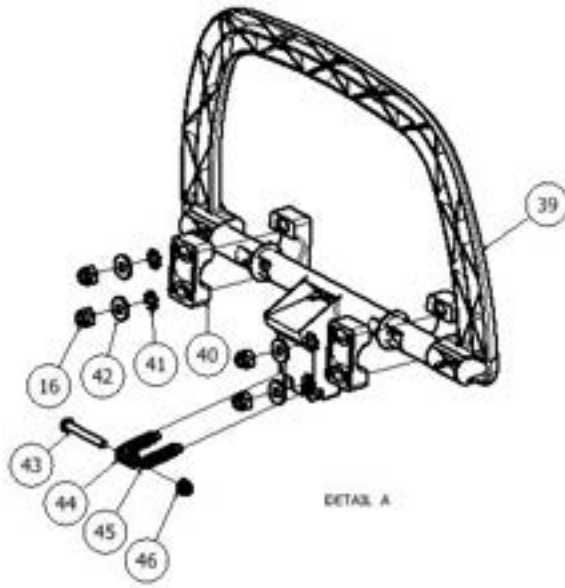

DETAIL A

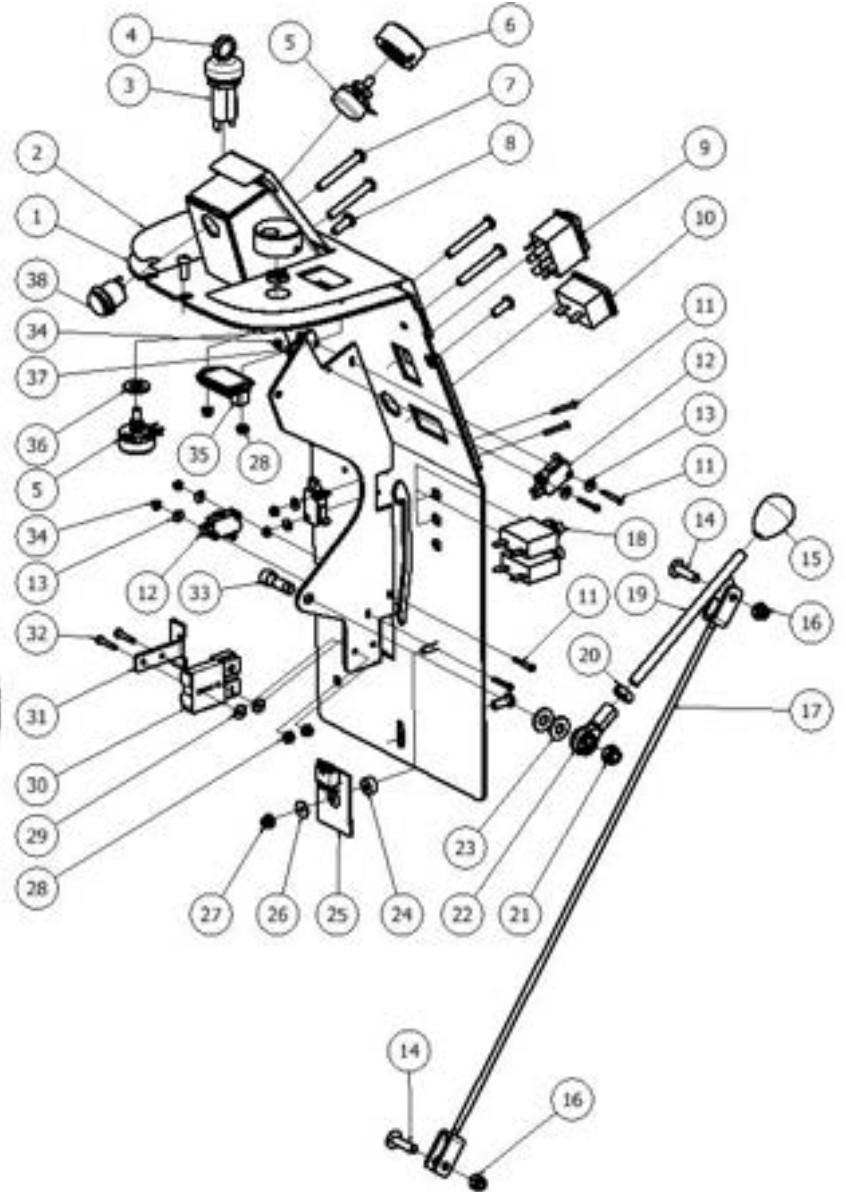
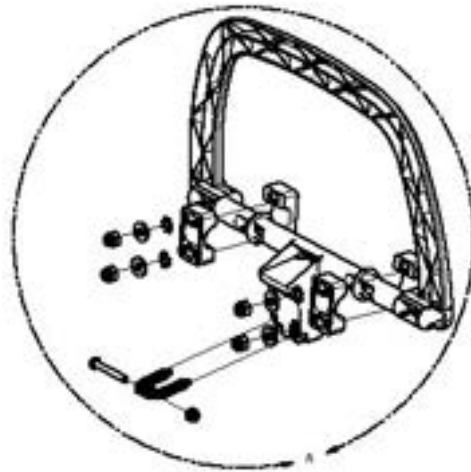

CONTROLS S-24 DISK

ITEM	QTY	PART NUMBER	DESCRIPTION
1	1	877101	PANEL, CONTROLS
2	1	875124	LABEL CONTROL 22GAL DISK
3	1	911647	SWITCH KEY
4	1	855012	KEY REPLMNT SCRUB 2-SET FOR 911647
5	2	911664	POTENTIOMETER ASSY, 5K
6	2	855001	KNOB, ADJUST, .25 BORE
7	4	962264	SCREW, BUTTON, SOCKET, .25 X 1.75, SS
8	4	962263	SCREW, BUTT, SOCK, .25-20X.62, SS BO
9	1	911649	SWITCH, ROCKER, AUTO ON-OFF
10	1	911661	METER, HOUR, DIGITAL
11	6	962273	SCREW, PAN, #4-40 X .88, ZINC
12	3	911646	SWITCH, SNAP, WITH ROLLER
13	6	980682	WASHER, FLAT, #4, ZINC
14	2	962455	SCREW, TRUSS, .25-20 X 1.0
15	1	855004	KNOB, OVAL, .31-18
16	6	920011	NUT, NYLOCK, 1/4-20, ZINC
17	1	852401	CABLE, LIFT, CLEVIS
18	2	911622	CIRCUIT BREAKER, 30 AMPS
19	1	855106	LEVER, LIFT, SQUEEGEE
20	1	920038	NUT, HEX, .31-24, SS
21	1	920012	NUT, NYLOCK, 5/16-18, ZINC
22	1	902050	BEARING, ROD END, .31-24
23	2	W243D	WASHER, FLAT, 5/16, SS
24	3	878208	SPACER PLASTIC #10 X .25 THICK
25	1	872413	CONTROLLER FLOW WATER
26	1	W401D	WASHER, FLAT, #10
27	1	920001	NUT, NYLOCK, #10-32, ZINC
28	4	920034	NUT, NYLOCK, #6-32, SS
29	6	980033	WASHER, FLAT, #6, SS
30	1	911645	HARNESS, CHARGER, POST
31	1	850806	BRACKET, PLUG

ITEM	QTY	PART NUMBER	DESCRIPTION
32	6	W132D	SCREW PAN #6-32 X 1.0 ZINC
33	1	962279	SCREW, SOCKET CAP, .31X1.0, SS
34	6	W385D	NUT, NYLOCK, #4-40, ZINC
35	1	911621	METER, BATTERY
36	1	980003	WASHER, FLAT, .38
37	1	856608	PLATE, MOUNTING
38	1	911653	SWITCH, ROUND, ON – MOM
39	1	851301	BAIL, MOLDED
40	4	855601	MOUNT, BEARING, PLASTIC
41	4	980029	WASHER, LOCK, .25, STAR, EXT
42	4	W104D	WASHER, FLAT, .25
43	1	962146	SCREW, PAN, #10-32 X 1.5, FULL, ZINC
44	1	920013	NUT, #10-32, ZINC
45	2	858302	SPRING, EXTENSION
46	2	920666	NUT, NYLOCK, #10-32, SS
47	1	911674	HARNESS, POWER, 24 INCH
48	1	911677	HARNESS, SIGNAL, 24 INCH
49	1	911722	HARNESS SOLUTION FLOW S-SERIES

*Items 47–49 not shown.

**Machines equipped with an off-board charging port use item 30 and the associated switch (items 11–13 & 34). Machines without the off-board charging port use item 31 in place.

CONTROLS

S-28 & S-32 DISK

(See additional diagrams for models equipped with BatteryShield®, chemical injection, or ScrubSmart® telemetry systems.)

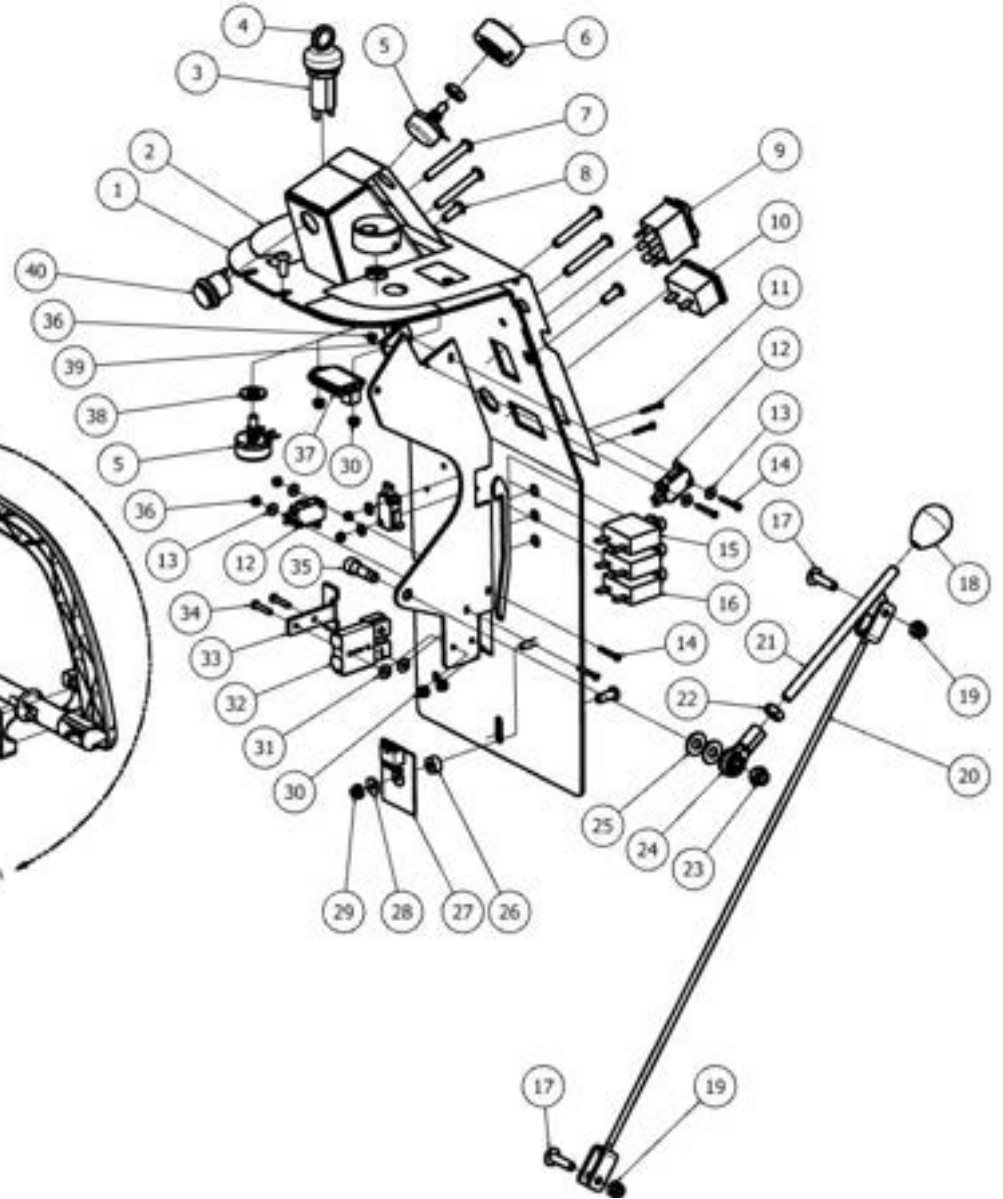
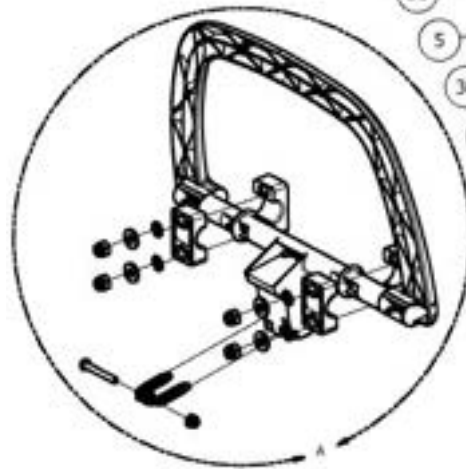
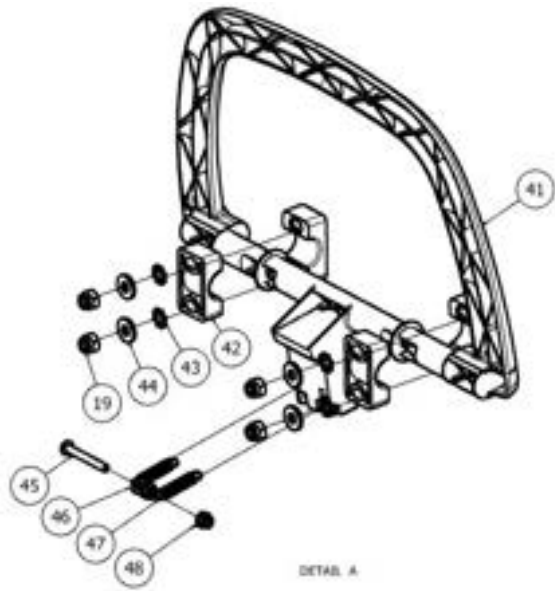

RETURN TO
TABLE OF
CONTENTS

CONTROLS S-28 & S-32 DISK

ITEM	QTY	PART NUMBER	DESCRIPTION
1	1	877101	PANEL, CONTROLS
2	1	875124	LABEL CONTROL 22GAL DISK
3	1	911647	SWITCH KEY
4	1	855012	KEY REPLMNT SCRUB 2-SET FOR 911647
5	2	911664	POTENTIOMETER ASSY, 5K
6	2	855001	KNOB, ADJUST, .25 BORE
7	4	962264	SCREW, BUTTON, SOCKET, .25 X 1.75, SS
8	4	962263	SCREW BHCS .25-20 X .63 SS BL
9	1	911649	SWITCH, ROCKER, AUTO ON-OFF
10	1	911661	METER, HOUR, DIGITAL
11	2	962209	SCREW PHPS 4-40 X .75 SS BL
12	3	911646	SWITCH, SNAP, WITH ROLLER
13	6	980682	WASHER, FLAT, #4, ZINC
14	4	962273	SCREW, PAN, #4-40 X .88, ZINC
15	1	911622	CIRCUIT BREAKER, 30 AMPS
16	2	911681	BREAKER, CIRCUIT, 35 AMPS
17	2	962455	SCREW, TRUSS, .25-20 X 1.0
18	1	855004	KNOB, OVAL, .31-18
19	6	920011	NUT, NYLOCK, 1/4-20, ZINC
20	1	852401	CABLE, LIFT, CLEVIS
21	1	855106	LEVER, LIFT, SQUEEGEE
22	1	920038	NUT, HEX, .31-24, SS
23	1	920012	NUT, NYLOCK, 5/16-18, ZINC
24	1	902050	BEARING, ROD END, .31-24
25	2	W243D	WASHER, FLAT, 5/16, SS
26	3	878208	SPACER PLASTIC #10 X .25 THICK
27	1	872413	CONTROLLER FLOW WATER
28	1	W401D	WASHER, FLAT, #10
29	1	920001	NUT, NYLOCK, #10-32, ZINC
30	4	920034	NUT, NYLOCK, #6-32, SS
31	6	980033	WASHER, FLAT, #6, SS

ITEM	QTY	PART NUMBER	DESCRIPTION
32	1	911645	HARNESS, CHARGER, POST
33	1	850806	BRACKET, PLUG
34	6	W132D	SCREW PAN #6-32 X 1.0 ZINC
35	1	962279	SCREW, SOCKET CAP, .31X1.0, SS
36	6	W385D	NUT, NYLOCK, #4-40, ZINC
37	1	911621	METER, BATTERY
38	1	980003	WASHER, FLAT, .38
39	1	856608	PLATE, MOUNTING
40	1	911653	SWITCH, ROUND, ON – MOM
41	1	851301	BAIL, MOLDED
42	4	855601	MOUNT, BEARING, PLASTIC
43	4	980029	WASHER, LOCK, .25, STAR, EXT
44	4	W104D	WASHER, FLAT, .25
45	1	962146	SCREW, PAN, #10-32 X 1.5, FULL, ZINC
46	1	920013	NUT, #10-32, ZINC
47	2	858302	SPRING, EXTENSION
48	2	920666	NUT, NYLOCK, #10-32, SS
49	1	911675	HARNESS, POWER, 28 & 32 INCH
50	1	911678	HARNESS, SIGNAL, 28 & 32 INCH
51	1	911722	HARNESS SOLUTION FLOW S-SERIES

*Items 49–51 not shown.

**Machines equipped with an off-board charging port use item 31 and the associated switch (items 12-14 & 36). Machines without the off-board charging port use item 33 in place.

CONTROLS S-28 ORBITAL

(See additional diagrams for models equipped with BatteryShield®, chemical injection, or ScrubSmart® telemetry systems.)

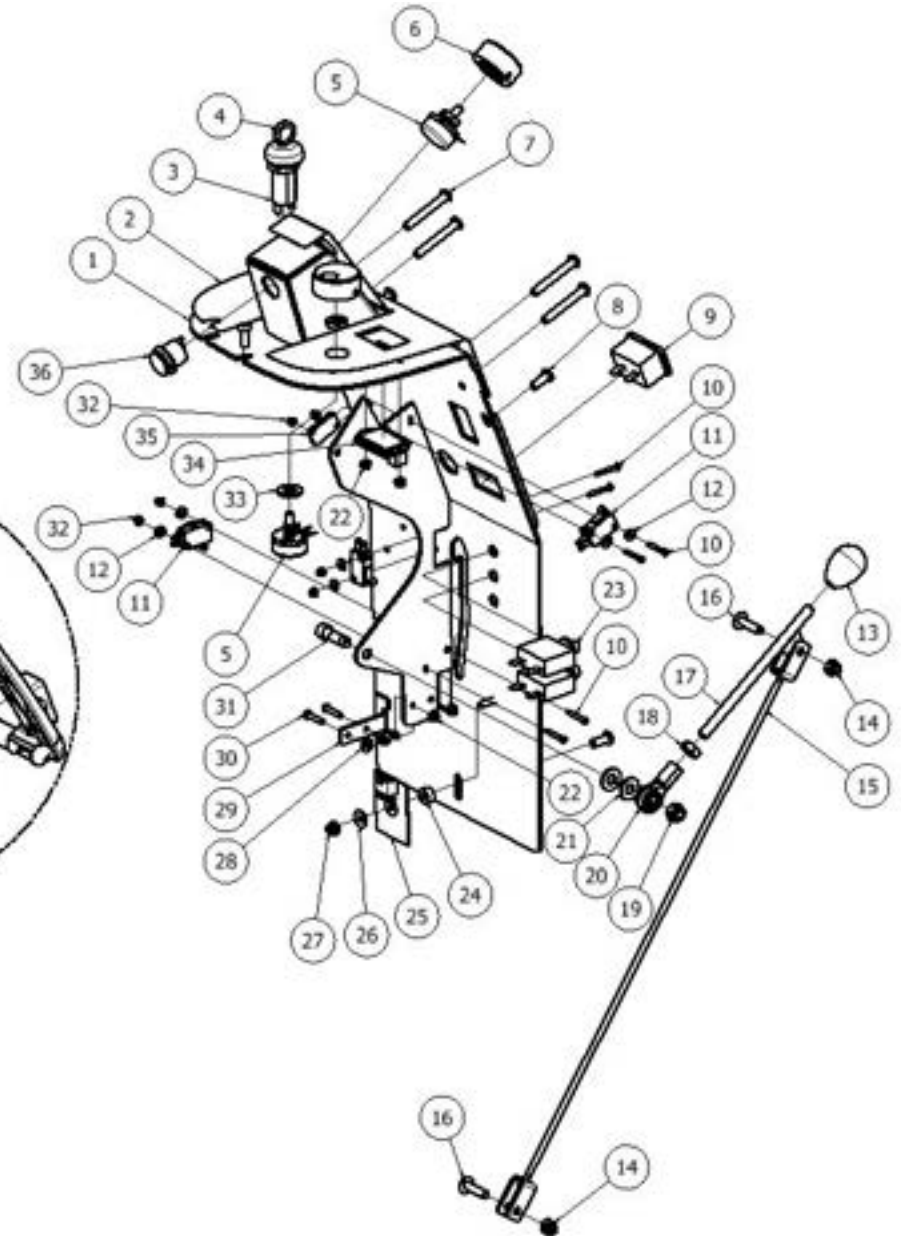
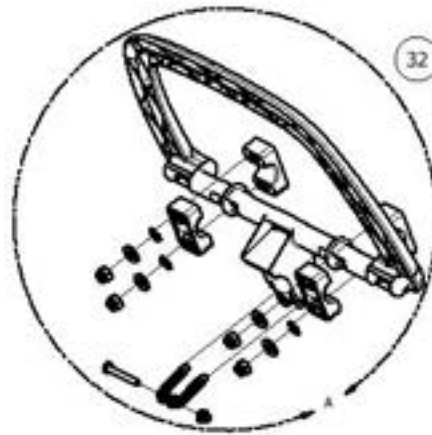
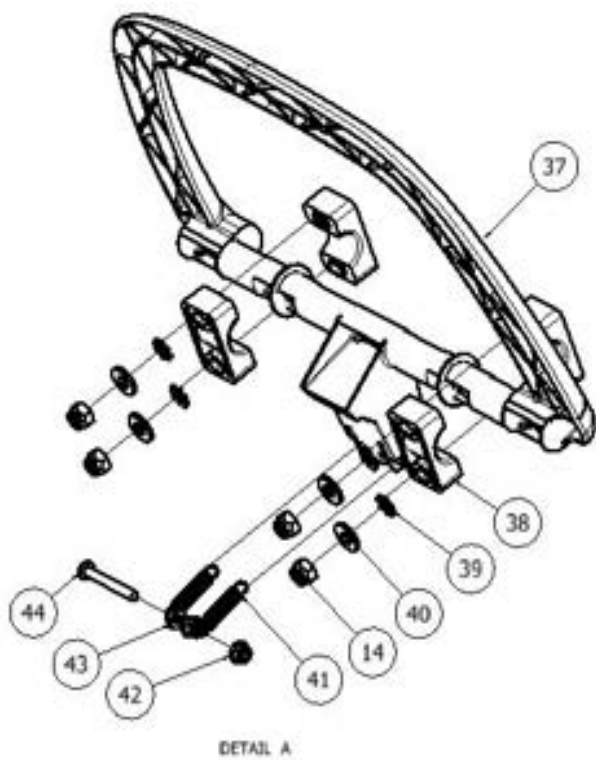

CONTROLS S-28 ORBITAL

ITEM	QTY	PART NUMBER	DESCRIPTION
1	1	877101	PANEL, CONTROLS
2	1	875125	LABEL CONTROL 22GAL ORB
3	1	911647	SWITCH KEY
4	1	855012	KEY REPLMNT SCRUB 2-SET FOR 911647
5	2	911664	POTENTIOMETER ASSY, 5K
6	2	855001	KNOB, ADJUST, .25 BORE
7	4	962264	SCREW, BUTTON, SOCKET, .25 X 1.75, SS
8	4	962263	SCREW, BUTT, SOCK, .25-20X.62, SS BO
9	1	911661	METER, HOUR, DIGITAL
10	6	962273	SCREW, PAN, #4-40 X .88, ZINC
11	3	911646	SWITCH, SNAP, WITH ROLLER
12	6	980682	WASHER, FLAT, #4, ZINC
13	1	855004	KNOB, OVAL, .31-18
14	6	920011	NUT, NYLOCK, 1/4-20, ZINC
15	1	852401	CABLE, LIFT, CLEVIS
16	2	962455	SCREW, TRUSS, .25-20 X 1.0
17	1	855106	LEVER, LIFT, SQUEEGEE
18	1	920038	NUT, HEX, .31-24, SS
19	1	920012	NUT, NYLOCK, 5/16-18, ZINC
20	1	902050	BEARING, ROD END, .31-24
21	2	W243D	WASHER, FLAT, 5/16, SS
22	4	920034	NUT, NYLOCK, #6-32, SS
23	2	911622	CIRCUIT BREAKER, 30 AMPS
24	3	878208	SPACER PLASTIC #10 X .25 THICK
25	1	872413	CONTROLLER FLOW WATER
26	1	W401D	WASHER, FLAT, #10
27	1	920001	NUT, NYLOCK, #10-32, ZINC
28	6	980033	WASHER, FLAT, #6, SS
29	1	850806	BRACKET, PLUG
30	6	W132D	SCREW PAN #6-32 X 1.0 ZINC
31	1	962279	SCREW, SOCKET CAP, .31X1.0, SS

ITEM	QTY	PART NUMBER	DESCRIPTION
32	6	W385D	NUT, NYLOCK, #4-40, ZINC
33	1	980003	WASHER, FLAT, .38
34	1	911621	METER, BATTERY
35	1	856608	PLATE, MOUNTING
36	1	911653	SWITCH, ROUND, ON - MOM
37	1	851301	BAIL, MOLDED
38	4	855601	MOUNT, BEARING, PLASTIC
39	4	980029	WASHER, LOCK, .25, STAR, EXT
40	4	W104D	WASHER, FLAT, .25
41	2	858302	SPRING, EXTENSION
42	2	920666	NUT, NYLOCK, #10-32, SS
43	1	920013	NUT, #10-32, ZINC
44	1	962146	SCREW, PAN, #10-32 X 1.5, FULL, ZINC
45	1	911645	HARNESS, CHARGER, POST
46	1	911676	HARNESS, POWER, 28 ORBITAL
47	1	911679	HARNESS, SIGNAL, 28 ORBITAL
48	1	911722	HARNESS SOLUTION FLOW S-SERIES
49	1	911684	HARNESS, BATTERYSHIELD

*Items 45-49 not shown.

CONTROLS OPTIONAL BATTERYSHIELD® & CHEMICAL INJECTION CONTROLS

ITEM	QTY	PART NUMBER	DESCRIPTION
1	1	875107	LED, RED, 24VDC
2	1	855115	LABEL BATTERYSHIELD WITH QR CODE
3	1	875104	LABEL, CONTROL, SOLUTION
4	2	878210	SPACER SOLUTION CONTROLLER
5	2	875001	KNOB, .25 BORE, SMALL
6	1	872401	CONTROLLER, DISPENSING
7	1	911680	HARNESS, SOLUTION CONTROL
8	1	911684	HARNESS, BATTERYSHIELD

*Items 7-8 not shown.

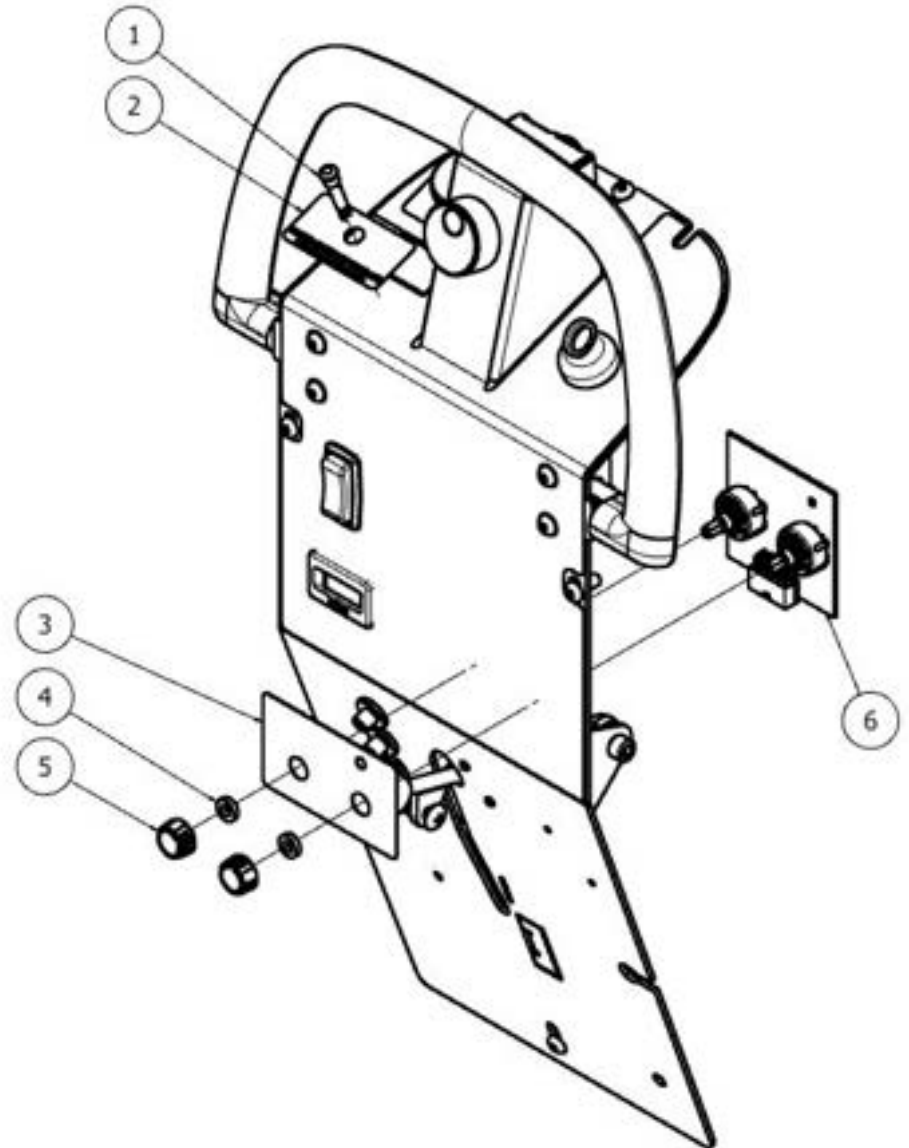

CONTROLS OPTIONAL SCRUBSMART® TELEMETRY SYSTEM

ITEM	QTY	PART NUMBER	DESCRIPTION
1	1	899203	TRANSMITTER TELEMETRY TRACKING
2	4	W132D	SCREW PAN #6-32 X 1.0 ZINC
3	6	980025	WASHER SPLIT LOCK #6 ZINC
4	6	980033	WASHER, FLAT, #6, SS
5	1	873805	GROMMET LOCKING 1/2" ID
6	2	878208	SPACER PLASTIC #10 X .25 THICK
7	1	870826	BRACKET MTG RELAY
8	1	911685	RELAY, 24VDC, BATTERYSHIELD
9	2	W315D	SCREW, PAN, #6-32 X .50, BLK
10	1	870827	BRACKET MTG KEYPAD
11	1	895002	KEYPAD TELEMETRY TRACKING
12	2	962460	SCREW, #8X.75, PHIL TRUSS SS

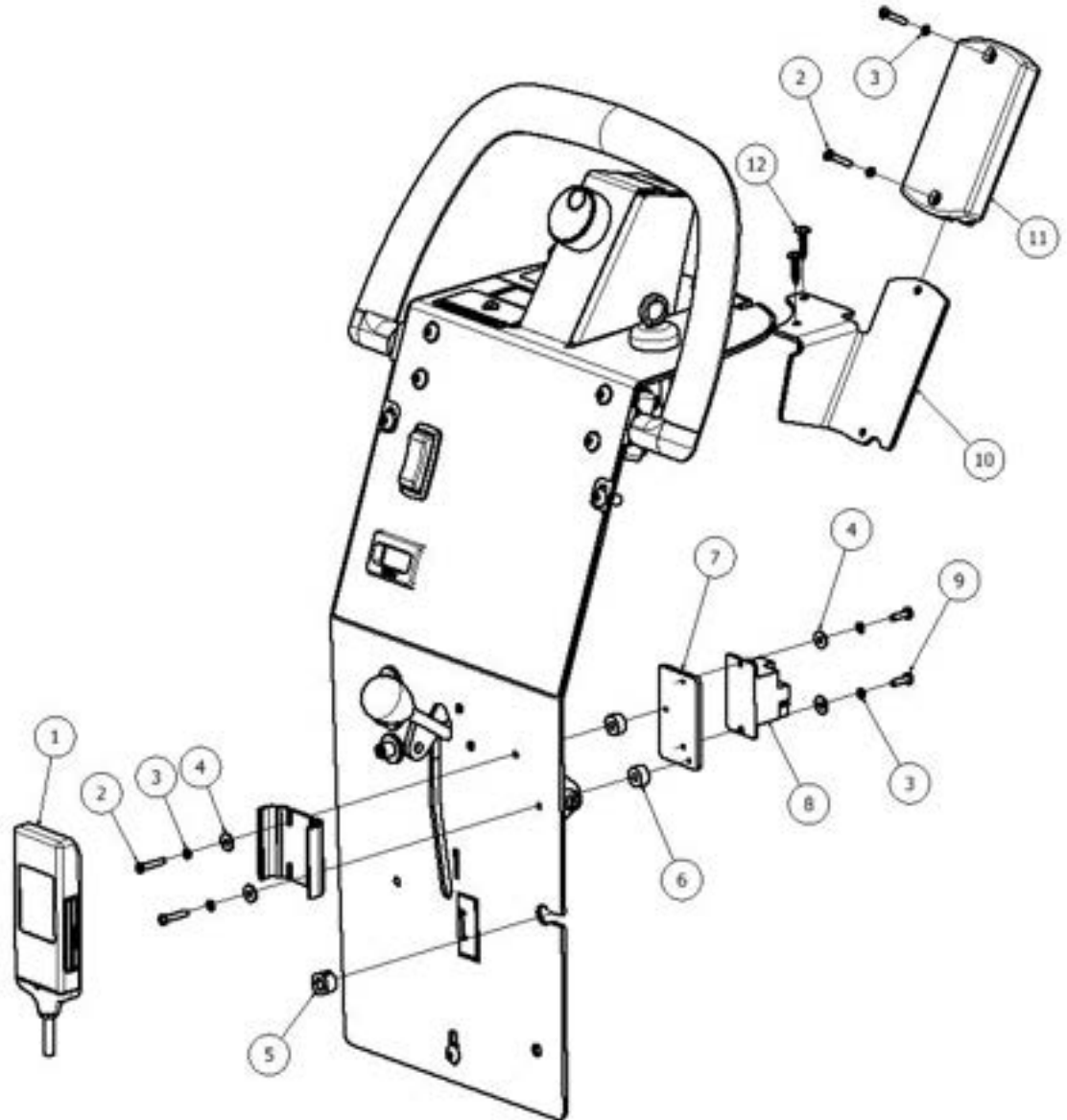

ELECTRONICS S-24 DISK

(See additional diagrams for models equipped with BatteryShield®.)

ITEM	QTY	PART NUMBER	DESCRIPTION
1	1	879801	PANEL, ELECTRONICS
2	1	912401	CONTACTOR, 24V, 100A
3	2	W401D	WASHER, FLAT, #10
4	4	980022	WASHER, LOCK, SPLIT, #10
5	4	962363	SCREW, PAN, #10-32 X .50, SS
6	4	W169D	SCREW, HEX, .25-20 X .50
7	6	980002	WASHER, LOCK, SPLIT, .25
8	6	W104D	WASHER, FLAT, .25
9	2	858501	STAND-OFF, INSULATED, .25-20
10	2	962276	SCREW, SET, .25-20 X 1.25, ZINC, PATCH
11	2	924083	NUT .25-20 FLEX LOCK ZINC
12	2	W323D	SCREW, PAN, #6-32 X 1.0, ZINC
13	4	980025	WASHER SPLIT LOCK #6 ZINC
14	1	879101	CONTROLLER, I-DRIVE, MID
15	2	912402	CONTACTOR, 24VDC, 70A

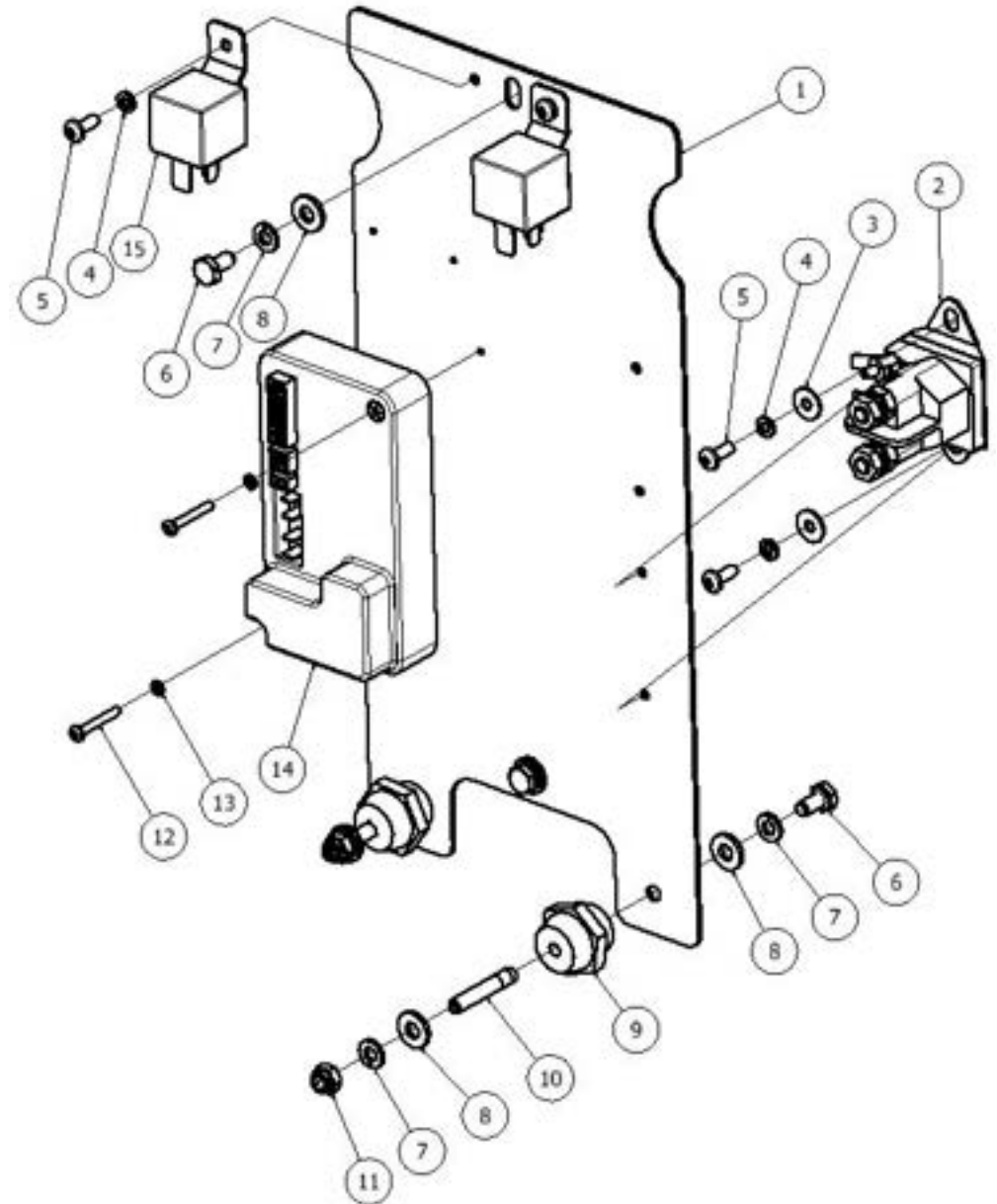

ELECTRONICS S-28 & S-32 DISK

(See additional diagrams for models equipped with BatteryShield®.)

ITEM	QTY	PART NUMBER	DESCRIPTION
1	1	879801	PANEL, ELECTRONICS
2	2	912401	CONTACTOR, 24V, 100A
3	4	W401D	WASHER, FLAT, #10
4	6	980022	WASHER, LOCK, SPLIT, #10
5	6	962363	SCREW, PAN, #10-32 X .50, SS
6	4	W169D	SCREW, HEX, .25-20 X .50
7	6	980002	WASHER, LOCK, SPLIT, .25
8	6	W104D	WASHER, FLAT, .25
9	2	858501	STAND-OFF, INSULATED, .25-20
10	2	962276	SCREW, SET, .25-20 X 1.25, ZINC, PATCH
11	2	924083	NUT .25-20 FLEX LOCK ZINC
12	2	W323D	SCREW, PAN, #6-32 X 1.0, ZINC
13	4	980025	WASHER SPLIT LOCK #6 ZINC
14	1	879101	CONTROLLER, I-DRIVE, MID
15	2	912402	CONTACTOR, 24VDC, 70A

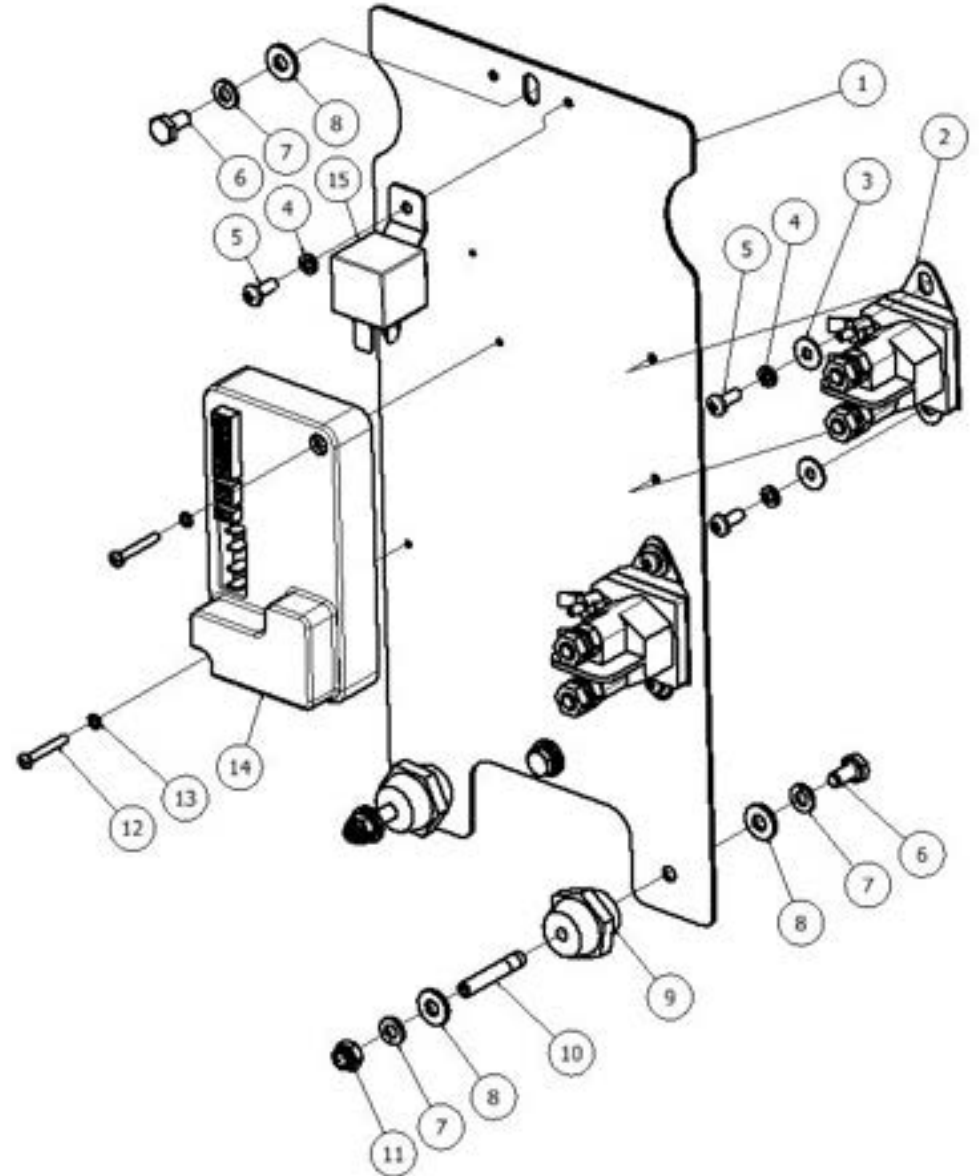

RETURN TO
TABLE OF
CONTENTS

ELECTRONICS S-28 ORBITAL

(See additional diagrams for models equipped with BatteryShield®.)

ITEM	QTY	PART NUMBER	DESCRIPTION
1	1	879801	PANEL, ELECTRONICS
2	1	912401	CONTACTOR, 24V, 100A
3	2	W401D	WASHER, FLAT, #10
4	3	980022	WASHER, LOCK, SPLIT, #10
5	3	962363	SCREW, PAN, #10-32 X .50, SS
6	4	W169D	SCREW, HEX, .25-20 X .50
7	6	980002	WASHER, LOCK, SPLIT, .25
8	6	W104D	WASHER, FLAT, .25
9	2	858501	STAND-OFF, INSULATED, .25-20
10	2	962276	SCREW, SET, .25-20 X 1.25, ZINC, PATCH
11	2	924083	NUT .25-20 FLEX LOCK ZINC
12	2	W323D	SCREW, PAN, #6-32 X 1.0, ZINC
13	4	980025	WASHER SPLIT LOCK #6 ZINC
14	1	879101	CONTROLLER, I-DRIVE, MID
15	2	912402	CONTACTOR, 24VDC, 70A

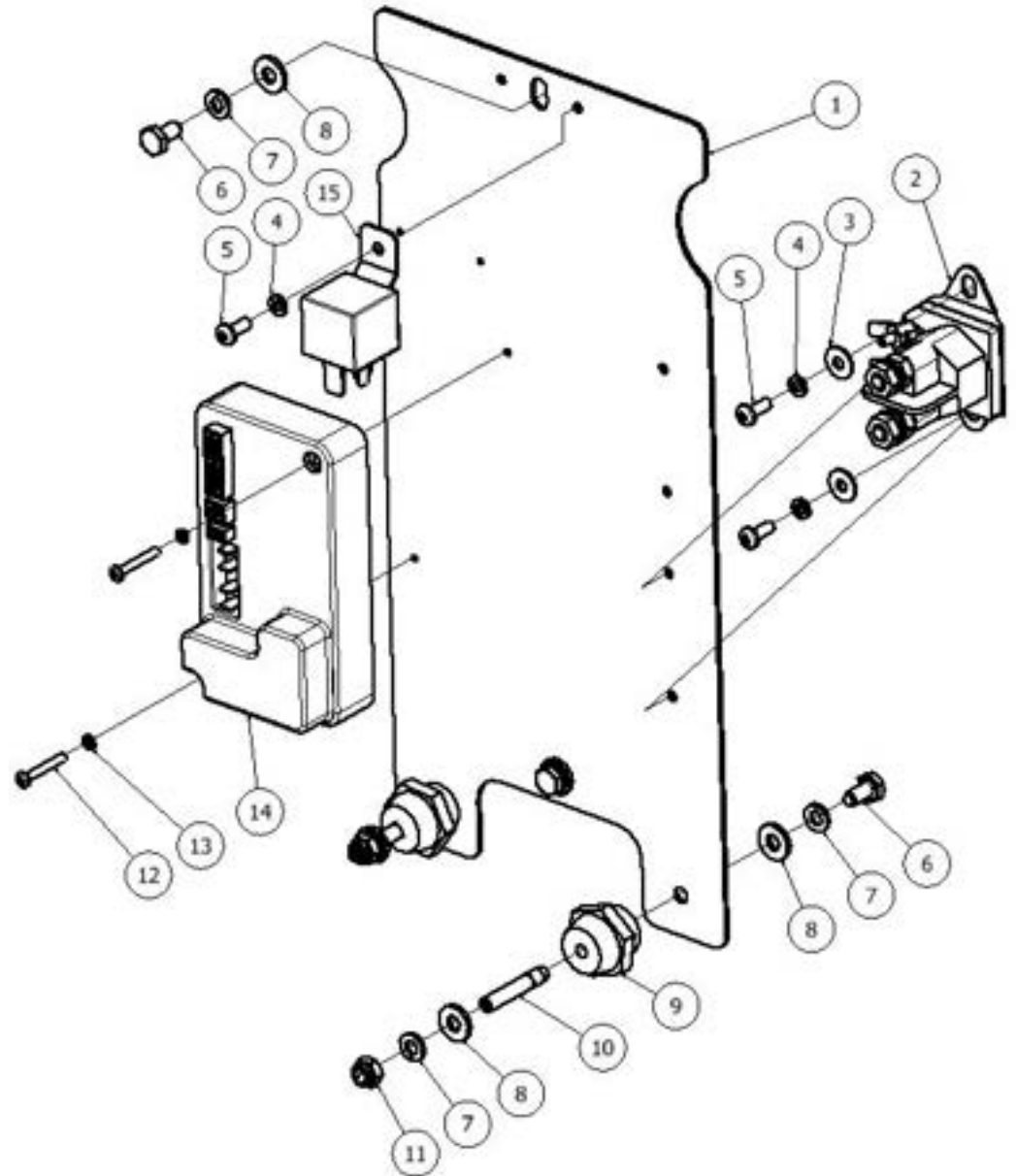

ELECTRONICS OPTIONAL BATTERYSHIELD®

ITEM	QTY	PART NUMBER	DESCRIPTION
1	1	911685	RELAY, 24VDC, BATTERYSHIELD
2	2	980033	WASHER, FLAT, #6, SS
3	2	980025	WASHER SPLIT LOCK #6 ZINC
4	2	W315D	SCREW, PAN, #6-32 X .50, BLK

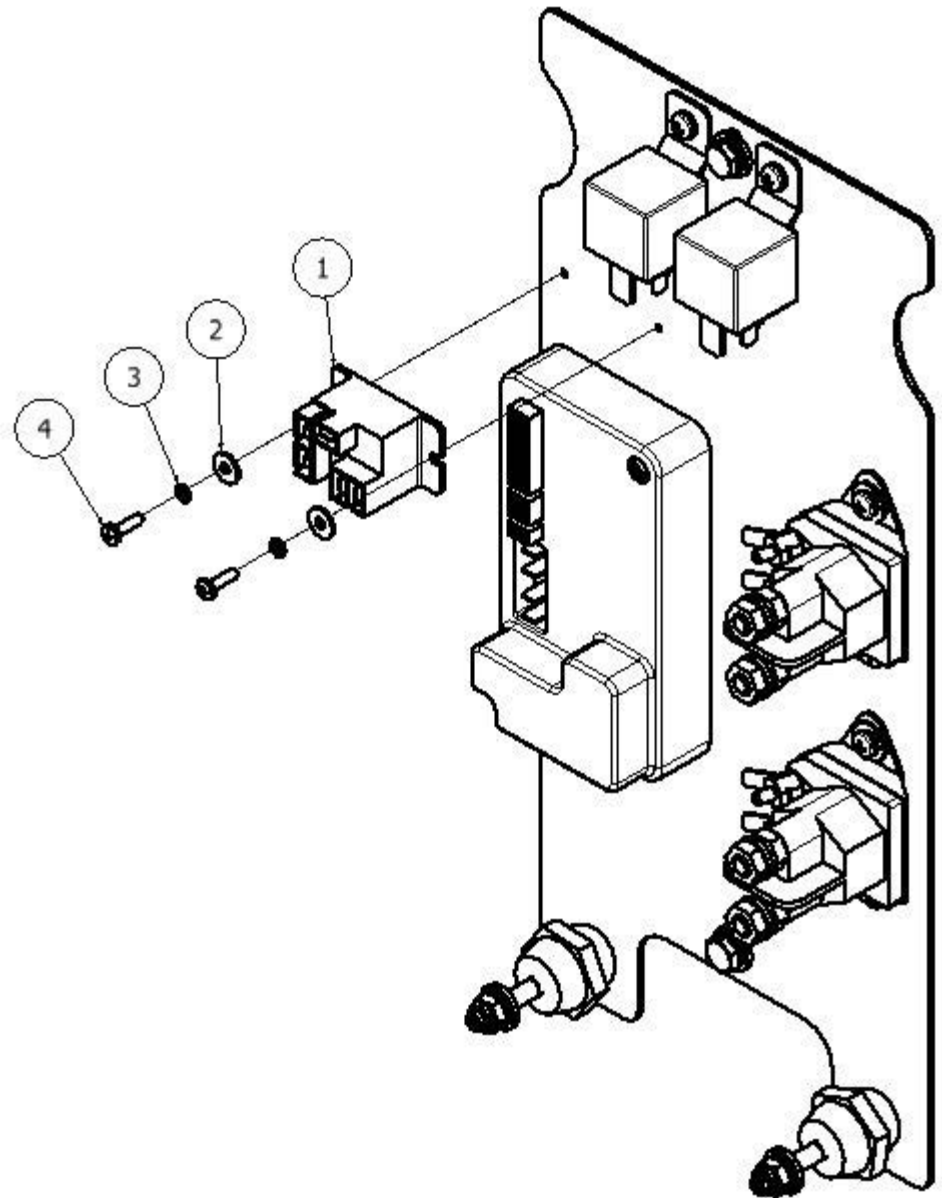

RETURN TO
TABLE OF
CONTENTS

FRAME ASSEMBLY

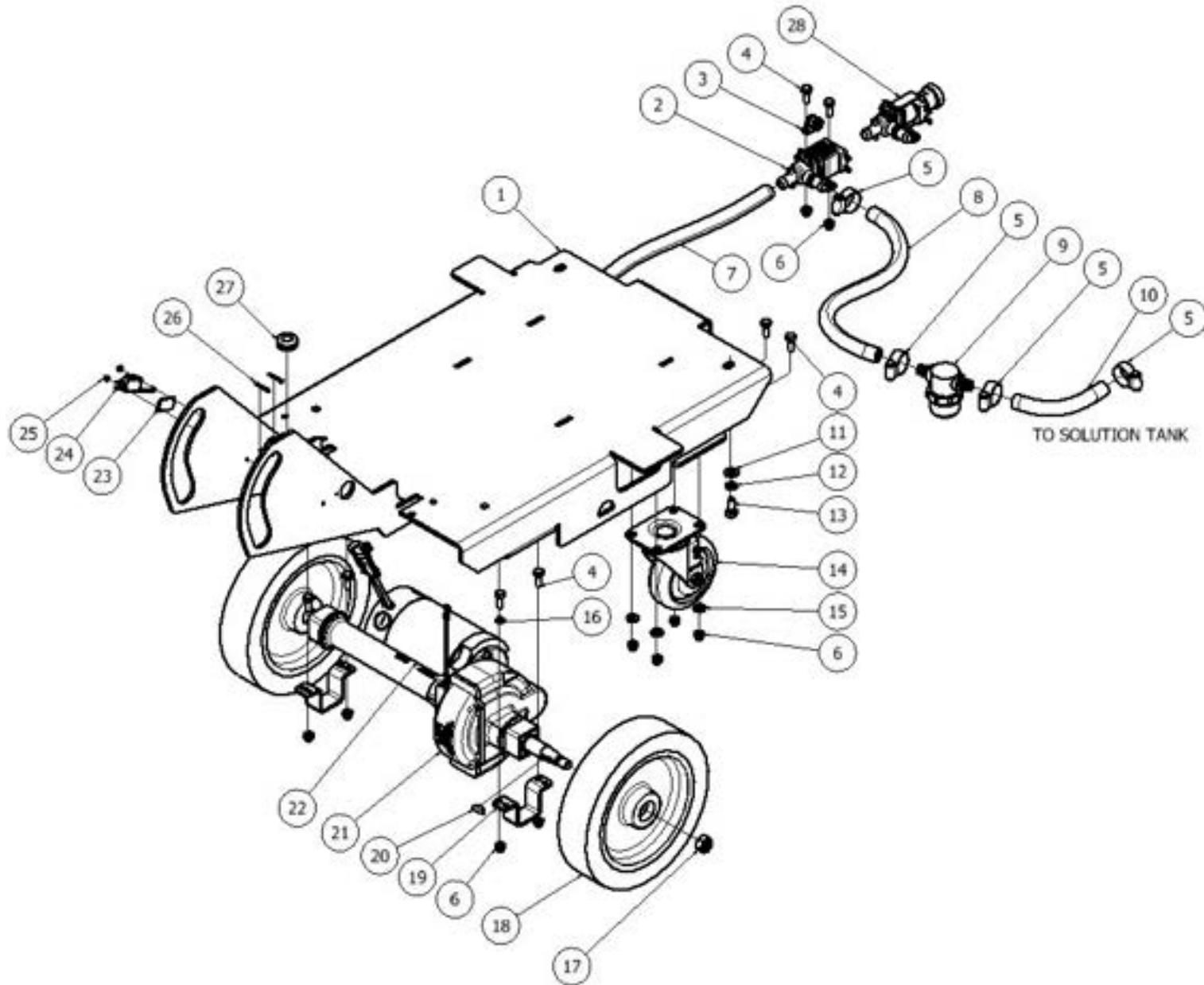

FRAME ASSEMBLY

ITEM	QTY	PART NUMBER	DESCRIPTION
1	1	873201	FRAME, SCRUBBER, 20 TRACT
2*	1	859402	VALVE SOLENOID 24V NONADJ
3	1	852101	CLAMP, WIRE, P-SHAPED
4	14	W189D	SCREW, HEX, 1/4-20 X .75, SS, PATCH
5	4	S453P	CLAMP, HOSE, WORM
6	14	920011	NUT, NYLOCK, 1/4-20, ZINC
7	1	224130 - 20.0"	TUBING, 1/2"
8	1	224130 - 14.0"	TUBING, 1/2"
9	1	843319	FILTER, SCREEN, BOWL
10	1	224130 - 5.12"	TUBING, 1/2"
11	4	W243D	WASHER, FLAT, 5/16, SS
12	4	980094	WASHER, SPLIT LOCK, .31, SS
13	4	962269	SCREW, HEX, .31-18 X .75, SS
14	2	875017	ASSY CASTER 4 INCH REPLACEMENT
15	8	W104D	WASHER, FLAT, .25
16	1	980029	WASHER, LOCK, .25, STAR, EXT
17	2	920648	NUT, M12, NYLOCK
18	2	879705	WHEEL URETHANE 222MM
19	2	850807	BRACKET, RETAINING, TRANS
20	2	915007	KEY, WOODRUFF, 5MM
21	1	879203	TRANSAXLE, 24VDC
22	1	875204	MOTOR REPL FOR TRANSAXLE 879203
23	1	856608	PLATE, MOUNTING
24	1	911682	SWITCH, SNAP, BENT LEVER
25	2	W385D	NUT, NYLOCK, #4-40, ZINC
26	2	962273	SCREW, PAN, #4-40 X .88, ZINC
27	1	873804	GROMMET .50ID .81HOLE .25THK
28*	1	855014	ASSY VALVE SCRUBBER REPLMNT
29**	1	870919	BRUSH KIT REPL FOR TRANSAXLE 879203

* For machines serial number 113191 and lower, use item 28 (870919).
 Machines produced after serial number 113191, use item 2 (859402).
 Machines with serial number greater than 113191 utilize the solution
 flow control on the control panel.

**Item 29 not shown.

HEAD LIFT

DISK HEAD MOUNTING HARDWARE

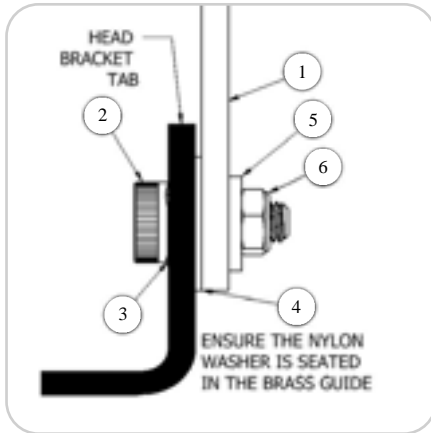

*LEFT SIDE SHOWN

ORBITAL HEAD MOUNTING HARDWARE

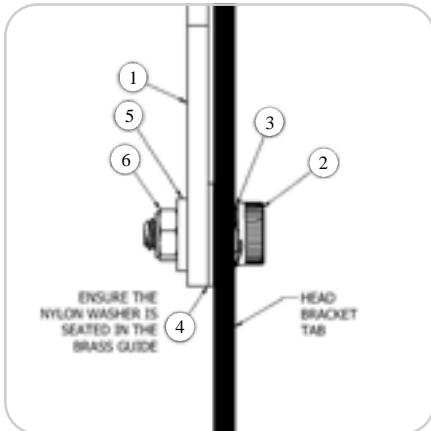

*LEFT SIDE SHOWN

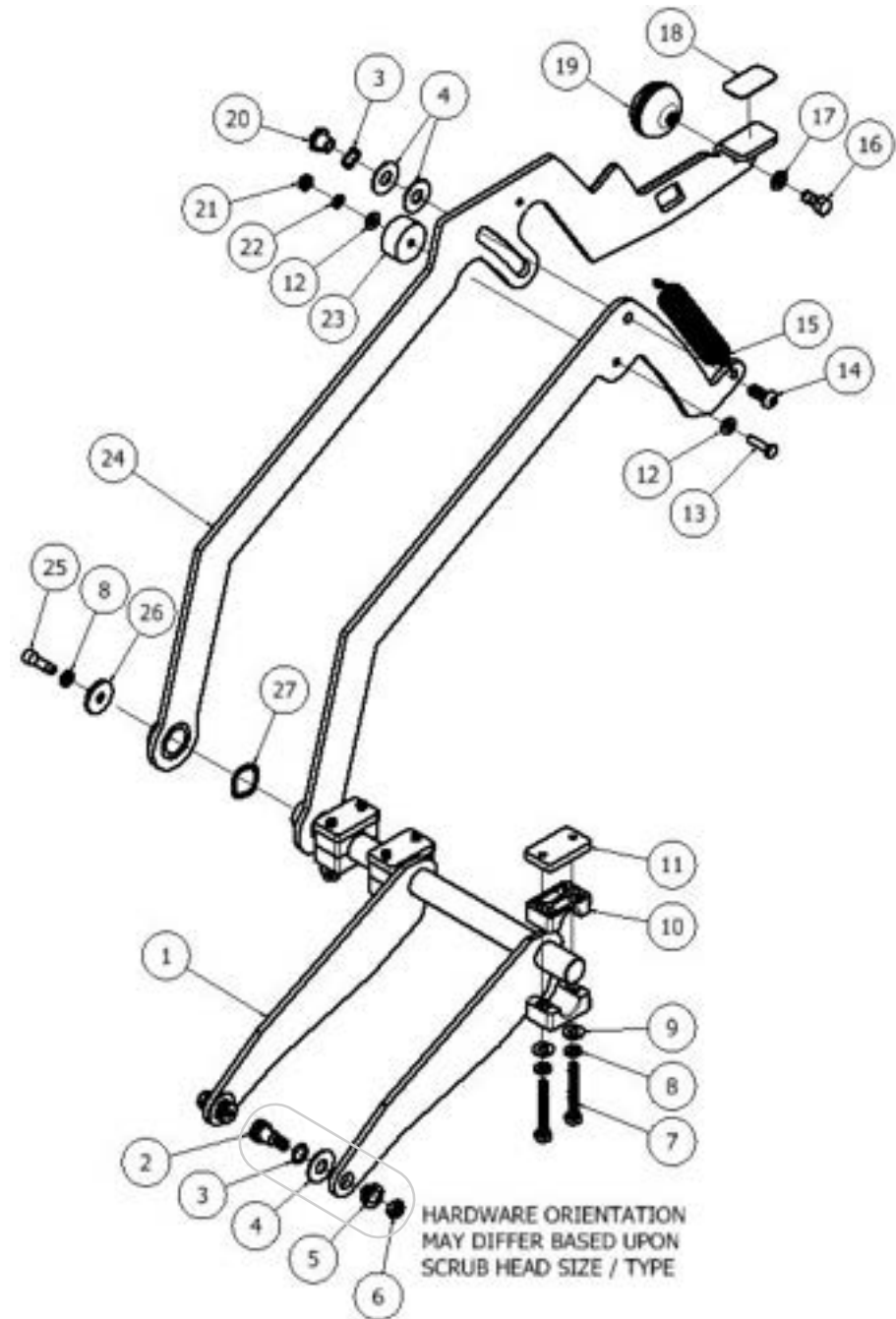

HEAD LIFT

ITEM	QTY	PART NUMBER	DESCRIPTION
1	1	870801	BRACKET, LIFT, HEAD
2	2	962465	SCREW, SHOULDER, .50 X .50
3	3	980093	WASHER, WAVE, .50INCH
4	4	980612	WASHER, NYL, .50 X 1.25 X .062
5	2	871101	BUSHING, FLANGE, .50IN
6	2	920035	NUT, NYLOCK, .38-16, SS
7*	6	962446	SCREW HH .31-18 X 2.25 SS
8*	7	980094	WASHER, SPLIT LOCK, .31, SS
9*	6	W243D	WASHER, FLAT, 5/16, SS
10*	6	875601	MOUNT, BEARING, PLASTIC
11*	3	870828	BRACKET BEARING MOUNT
12	2	W104D	WASHER, FLAT, .25
13	1	962221	SCREW, HEX, .25-20 X 1.0, SS
14	1	964256	SCREW .38-16X.88 BUTT SCK ZNC PTCH
15	1	878301	SPRING, EXTENSION
16	1	962028	SCREW, HX, .38-24X.75,SS,PTCH
17	1	980009	WASHER, SPLIT LOCK, 3/8, SS
18	1	875105	LABEL, FOOT, GRIP, LARGE
19	1	875002	KNOB, PLASTIC, LARGE
20	1	878207	SPACER LIFT ARM
21	1	920037	NUT, THIN JAM, 1/4-20, ZINC
22	1	980002	WASHER, LOCK, SPLIT, .25
23	1	858205	SPACER, RUBBER
24	1	875106	LEVER, DOWNPRESSURE
25	1	962279	SCREW, SOCKET CAP, .31X1.0, SS
26	1	980108	WASHER, FLAT, .31ID, 1.25OD, .12THK, SS
27	1	980785	WASHER WAVE 1.0INCH SS

*ITEMS 7-11 CAN BE ORDERED AS A KIT UNDER PART NUMBER 875028 - KIT MOUNT HEAD LIFT REPLACEMENT.

SOLUTION TANK

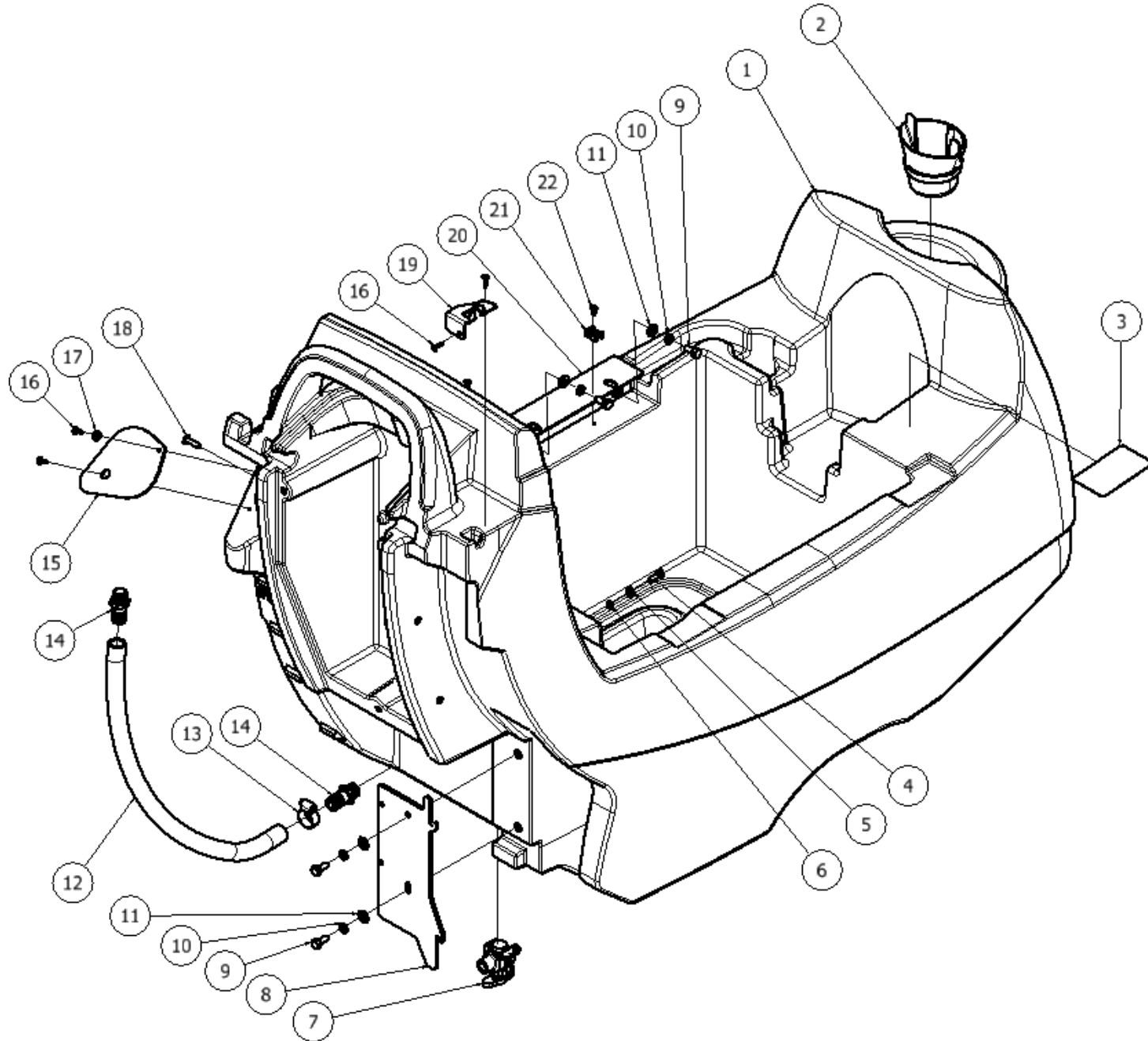

SOLUTION TANK

ITEM	QTY	PART NUMBER	DESCRIPTION
1	1	878601	TANK, SOLUTION, 22 GAL
2	1	875011	KIT, STRAINER, PORT, FILL
3	1	875103	LABEL, INSTRUCTION, BATTERY
4	1	W189D	SCREW, HEX, 1/4-20 X .75, SS, PATCH
5	1	920037	NUT, THIN JAM, 1/4-20, ZINC
6	1	980002	WASHER, LOCK, SPLIT, .25
7	1	879401	VALVE, SHUT-OFF, BALL
8	1	870805	BRACKET, SUPPORT, LEVER
9	5	962269	SCREW, HEX, .31-18 X .75, SS
10	5	980094	WASHER, SPLIT LOCK, .31, SS
11	5	W243D	WASHER, FLAT, 5/16, SS
12	1	879004	TUBE, SIGHT, REPLACEMENT
13	1	S453P	CLAMP, HOSE, WORM
14	2	853303	FITTING, STR, BM12, PM08
15	1	872304	COVER, PORT, FILL
16	4	962460	SCREW, #8X.75, PHIL TRUSS SS
17	1	W401D	WASHER, FLAT, #10
18	1	962455	SCREW, TRUSS, .25-20 X 1.0
19	1	870819	BRACKET, RETENTION, HANGER
20	1	874501	HINGE, TANK, RECOVERY
21	4	225670	PAD, WIRE TIE
22	4	962271	SCREW, PAN, #10 X .38L, ZINC

OPTIONAL CHEMICAL INJECTION SYSTEM

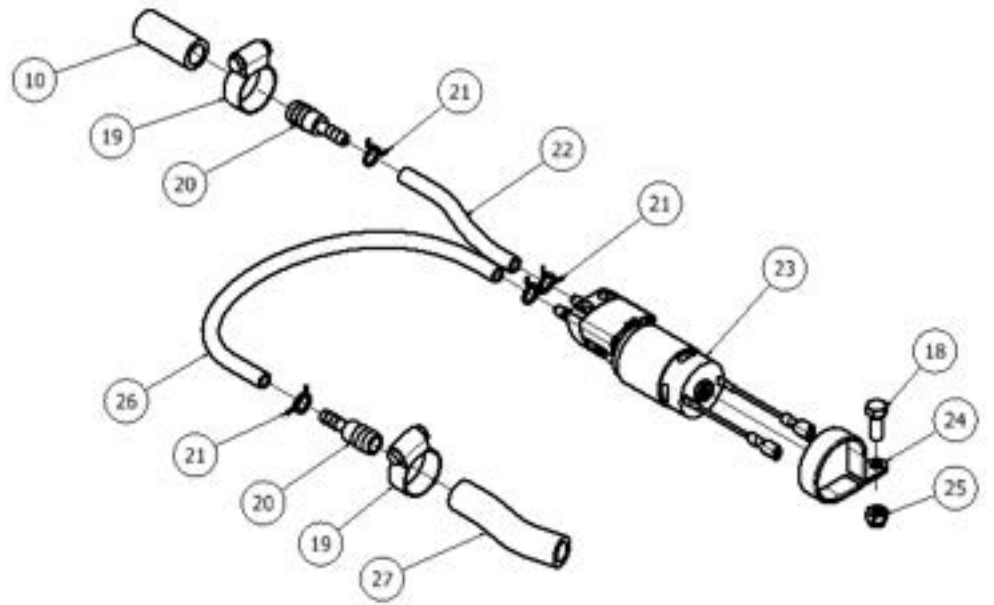
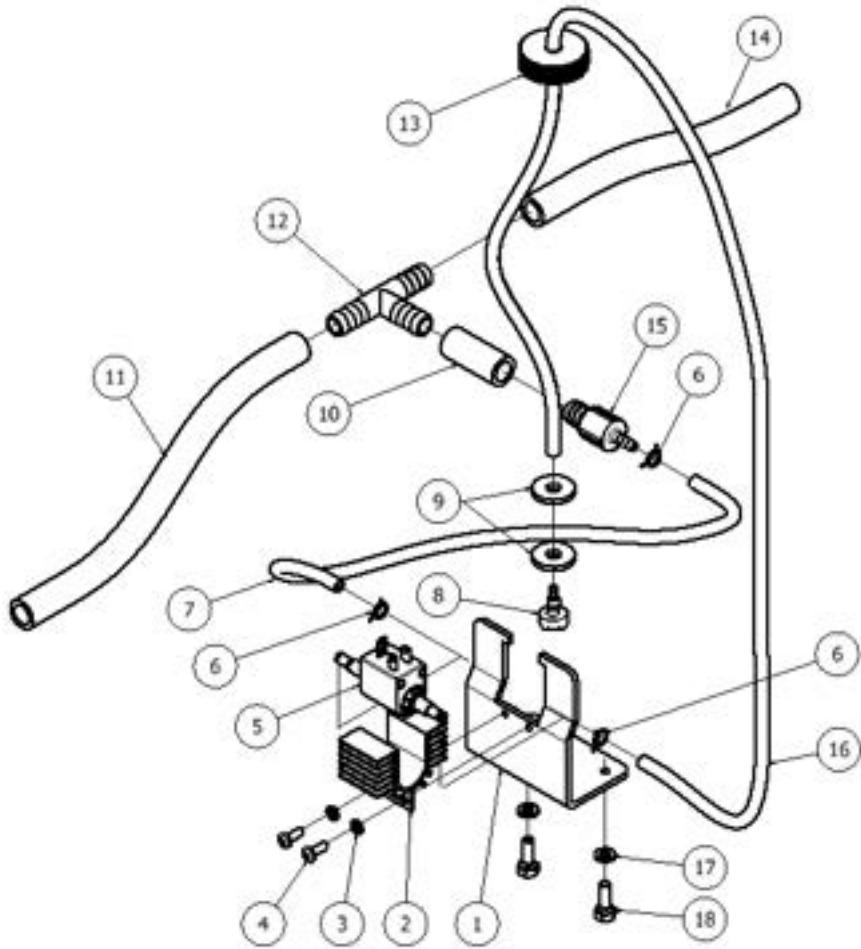

OPTIONAL CHEMICAL INJECTION SYSTEM

ITEM	QTY	PART NUMBER	DESCRIPTION
1	1	870811	BRACKET, MTG, HEAT SINK
2	1	870810	BRACKET, HEAT SINK
3	2	980022	WASHER, LOCK, SPLIT, #10
4	2	962363	SCREW, PAN, #10-32 X .50, SS
5	1	877002	PUMP, 24VDC, SOLENOID, EMX08
6	3	872002	CLAMP, HOSE, .31, WIRE
7	1	879003 - 10.0"	TUBING, 3/16"
8	1	S764P2	FILTER, STRAINER
9	2	980107	WASHER, FLAT, .31ID, 1.0OD, .12THK, SS
10	2	224130	TUBING, 1/2"
11	1	224130 - 1.62"	TUBING, 1/2"
12	1	873308	FITTING, TEE, 0.50 INCH
13	1	871501	CAP, 38MM, WITH HOLE
14	1	224130	TUBING, 1/2"
15	1	879402	VALVE, CHECK, .188 X .50 BARB
16	1	879003 - 42.0"	TUBING, 3/16"
17	2	980002	WASHER, LOCK, SPLIT, .25
18	3	W189D	SCREW, HEX, 1/4-20 X .75, SS, PATCH
19	2	S453P	CLAMP, HOSE, WORM
20	2	853301	FITTING, REDUCER, BM08, BM04
21	4	872003	CLAMP, HOSE, .38, WIRE
22	1	224130	TUBING, 1/2"
23	1	877005	PUMP, GEAR, 24VDC
24	1	872001	CLAMP, P-SHAPED, 1.5 DIA
25	1	920011	NUT, NYLOCK, 1/4-20, ZINC
26	1	224130	TUBING, 1/2"
27	1	224130 - 3.38"	TUBING, 1/2"

RECOVERY TANK ASSEMBLY

*** PRIOR TO SERIAL NUMBER 123255 – CONFIRM SERIAL NUMBER BEFORE ORDERING REPLACEMENT PARTS ***

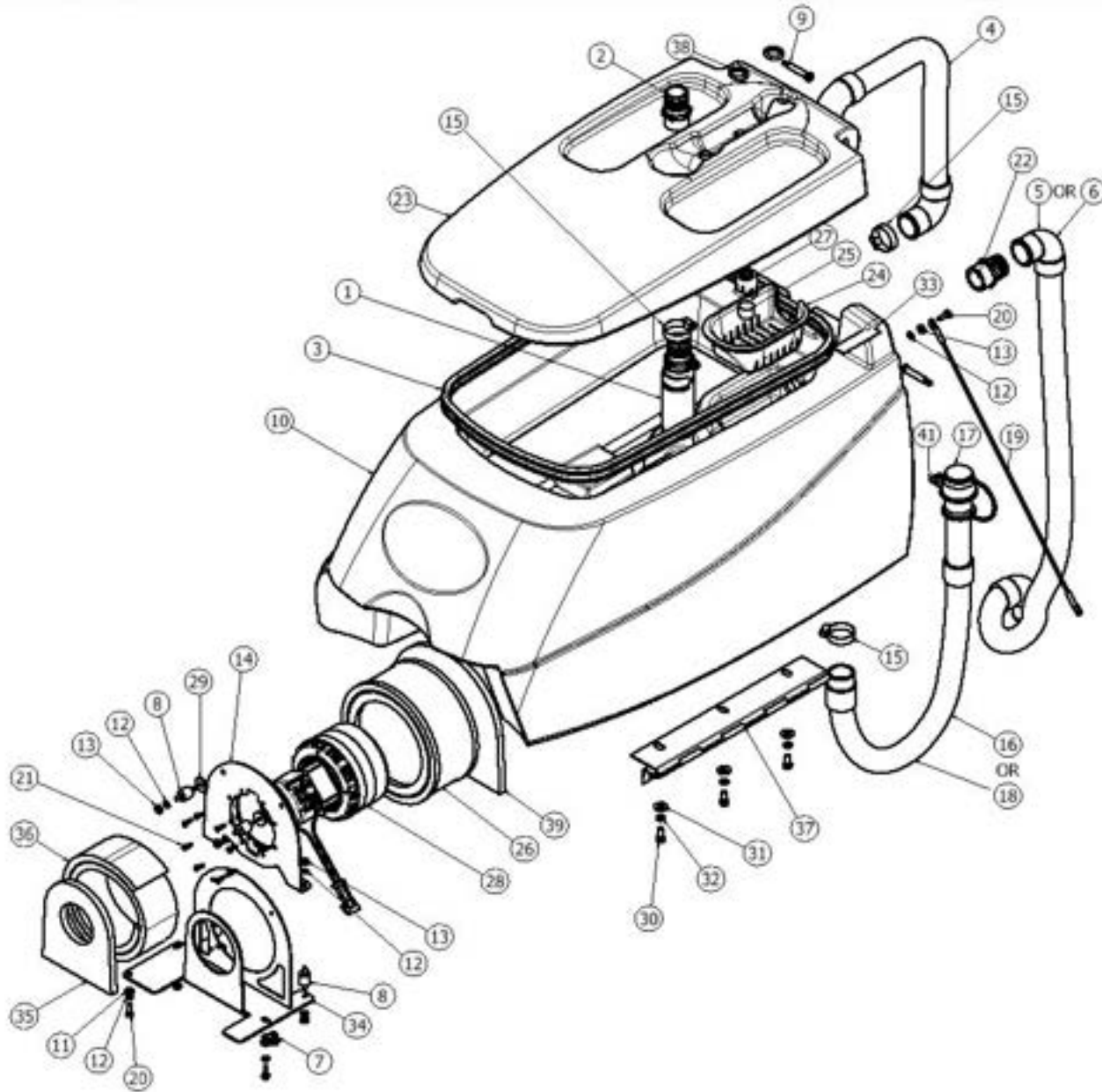

RECOVERY TANK ASSEMBLY

***** PRIOR TO SERIAL NUMBER 123255 – CONFIRM SERIAL NUMBER BEFORE ORDERING REPLACEMENT PARTS *****

ITEM	QTY	PART NUMBER	DESCRIPTION
1	2	223370	FLOAT, SHUTOFF
2	2	853304	FITTING, STR, BM24, PM20
3	1	873401	GASKET, COVER, PRESS-IN
4	1	854103	HOSE, VACUUM, 1.5INCH
5	1	874101	HOSE, SQUEEGEE, 90 CUFF
6	1	874102	HOSE SQUEEGEE MID CHEM RESIST
7	1	852101	CLAMP, WIRE, P-SHAPED
8	4	855603	MOUNT, RUBBER, .25-20
9	2	962462	SCREW, SHOULDER, .38 X 1.75, SS
10	1	878602	TANK, RECOVERY, 22 GAL
11	3	W104D	WASHER, FLAT, .25
12	12	980002	WASHER, LOCK, SPLIT, .25
13	9	920037	NUT, THIN JAM, 1/4-20, ZINC
14	1	870806	BRACKET, MTG, ISOLATOR
15	4	S611A	CLAMP, HOSE, WORM
16	1	854101	HOSE, DRAIN, CAPPED
17	1	851501	CAP HOSE DRAIN - REPL FOR 854101
18	1	854104	HOSE DRAIN CAPPED CHEM RESIST
19	1	872412	CABLE RETENTION MID LONG
20	4	W189D	SCREW, HEX, 1/4-20 X .75, SS, PATCH
21	8	964224	SCREW PHPS M5.5 X 16 ZINC PLASTIC
22	1	853308	FITTING, MODIFIED
23	1	872301	COVER, TANK, RECOVERY
24	1	879201	TRAY, DEBRIS
25	1	877007	PUCK, BROMINE (4-PACK)
26	1	873304	FILTER, HEPA, MID
27	1	879202	TRAY, PUCK
28	2	875202	MOTOR, VACUUM, 24VDC, 3-STAGE
29	2	980106	WASHER, FLAT, .25ID, 1.0OD, .12THK, SS
30	3	962269	SCREW, HEX, .31-18 X .75, SS
31	3	W243D	WASHER, FLAT, 5/16, SS

ITEM	QTY	PART NUMBER	DESCRIPTION
32	3	980094	WASHER, SPLIT LOCK, .31, SS
33	1	875110	LABEL, INSTRUCT, BROMINE
34	1	872303	COVER, MTG, VACUUM
35	1	873314	GASKET, FOAM, VACUUM
36	1	853305	FOAM, NOISE, VACUUM
37	1	874501	HINGE, TANK, RECOVERY
38	2	856803	PLUG HOLE 1 INCH BLACK
39	1	873315	FOAM BARRIER NOISE
40	1	858506	STRAP SUPPORT HOSE

AVAILABLE VACUUM MOTOR KIT - #875023

ITEM	DESCRIPTION	QTY
877802	SHEET INSTR MID-SCRUBBER VAC MTR REPL	1
873314	GASKET, FOAM, VACUUM	1
875202	MTR, VAC, 24VDC, 3STG - KIT 875023 AVAIL	1
873315	FOAM BARRIER NOISE MID	1
853305	FOAM,NOISE,VACUUM	1

RECOVERY TANK ASSEMBLY

*** AFTER SERIAL NUMBER 123254 – CONFIRM SERIAL NUMBER BEFORE ORDERING REPLACEMENT PARTS ***

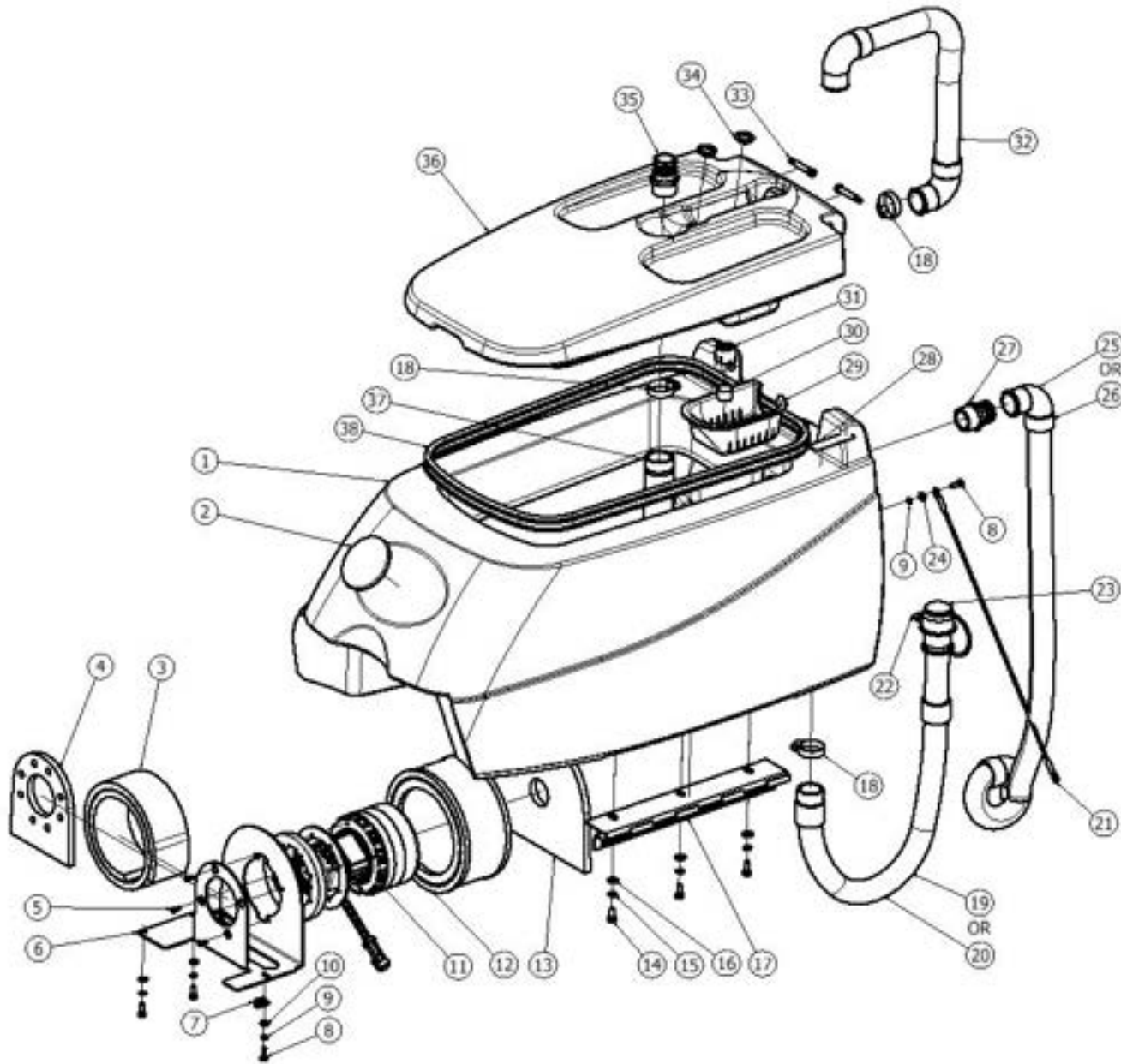

RECOVERY TANK ASSEMBLY

*** AFTER SERIAL NUMBER 123254 – CONFIRM SERIAL NUMBER BEFORE ORDERING REPLACEMENT PARTS ***

ITEM	QTY	PART NUMBER	DESCRIPTION
1	1	878602	TANK, RECOVERY, 22 GAL
2	1	895113	LABEL PACIFIC 4INCH ROUND
3	1	853305	FOAM, NOISE, VACUUM
4	1	873314	GASKET, FOAM, VACUUM
5	4	964224	SCREW PHPS M5.5 X 16 ZINC PLASTIC
6	1	872312	COVER MTG VACUUM
7	1	852101	CLAMP, WIRE, P-SHAPED
8	4	W189D	SCREW HH .25-20 X .75 SS
9	4	980002	WASHER, LOCK, SPLIT, .25
10	3	W104D	WASHER, FLAT, .25
11	2	875202	MOTOR, VACUUM, 24VDC, 3-STAGE
12	1	873304	FILTER, HEPA, MID
13	1	873315	FOAM BARRIER NOISE
14	3	962206	SCREW HH .31-18 X .75 SS W PATCH
15	3	980094	WASHER, SPLIT LOCK, .31, SS
16	3	W243D	WASHER, FLAT, 5/16, SS
17	1	874501	HINGE, TANK, RECOVERY
18	3	S611A	CLAMP HOSE 1.0 - 2.0 SS
19	1	854101	HOSE, DRAIN, CAPPED
20	1	854104	HOSE DRIAN CAPPED CHEM RESIST
21	1	872412	CABLE RETENTION MID LONG
22	1	858506	STRAP SUPPORT HOSE
23	1	851501	CAP HOSE DRAIN - REPL FOR 854101
24	1	920037	NUT HEX .25-20 SS THIN
25	1	874101	HOSE, SQUEEGEE, 90 CUFF
26	1	874102	HOSE SQUEEGEE MID CHEM RESIST
27	1	853308	FITTING, MODIFIED
28	1	875110	LABEL, INSTRUCT, BROMINE
29	1	879201	TRAY, DEBRIS
30	1	877007	PUCK, BROMINE (4-PACK)
31	1	879202	TRAY, PUCK

ITEM	QTY	PART NUMBER	DESCRIPTION
32	1	854103	HOSE, VACUUM, 1.5INCH
33	2	962462	SCREW SHLDR .38 DIA X 1.75 .31-18 SS PATCH
34	2	856803	PLUG HOLE 1 INCH BLACK
35	1	853304	FITTING, STR, BM24, PM20
36	1	872301	COVER, TANK, RECOVERY
37	1	223370	FLOAT, SHUTOFF
38	1	873401	GASKET, COVER, PRESS-IN

AVAILABLE VACUUM MOTOR KIT - #875023

ITEM	DESCRIPTION	QTY
877802	SHEET INSTR MID-SCRUBBER VAC MTR REPL	1
873314	GASKET, FOAM, VACUUM	1
875202	MTR, VAC, 24VDC, 3STG - KIT 875023 AVAIL	1
873315	FOAM BARRIER NOISE MID	1
853305	FOAM,NOISE,VACUUM	1

SQUEEGEE LINKAGE

ITEM	QTY	PART NUMBER	DESCRIPTION
1	1	870803	BRACKET, SWING, SQUEEGEE
2	1	980107	WASHER, FLAT, .31ID, 1.0OD, .12THK, SS
3	1	962270	SCREW, HEX, 5/16-18X1.75,SS
4	1	878204	SPACER, GUIDE, SQUEEGEE
5	1	877501	GUIDE, ROLLER, SQUEEGEE
6	1	870802	BRACKET, LINK, SQUEEGEE
7	2	875003	KNOB, THREADED, .31-18 X 1.5
8	2	877207	RETAINER, FRAME, SQUEEGEE
9	9	920040	NUT, .31-18, NYLOCK, SS, LOW
10	2	962464	SCREW, BUTTON, .31-18 X 1.25, ZINC
11	8	980105	WASHER, PLASTIC, THRUST
12	1	850501	AXLE, WHEEL, SQUEEGEE
13	2	849709	WHEEL, 2 OD, .31 ID
14	1	962075	SCREW, HEX, 3/8-16 X 1.5, SS
15	1	962028	SCREW, HX, .38-24X.75,SS,PTCH
16	1	980003	WASHER, FLAT, .38
17	1	878504	STRAP, GROUNDING, STATIC
18	1	902051	BEARING, ROD END, .38 FEM
19	1	920032	NUT .38-16 NYLOCK THIN ZINC
20	2	962465	SCREW, SHOULDER, .50 X .50
21	2	871101	BUSHING, FLANGE, .50IN
22	2	920035	NUT, NYLOCK, .38-16, SS

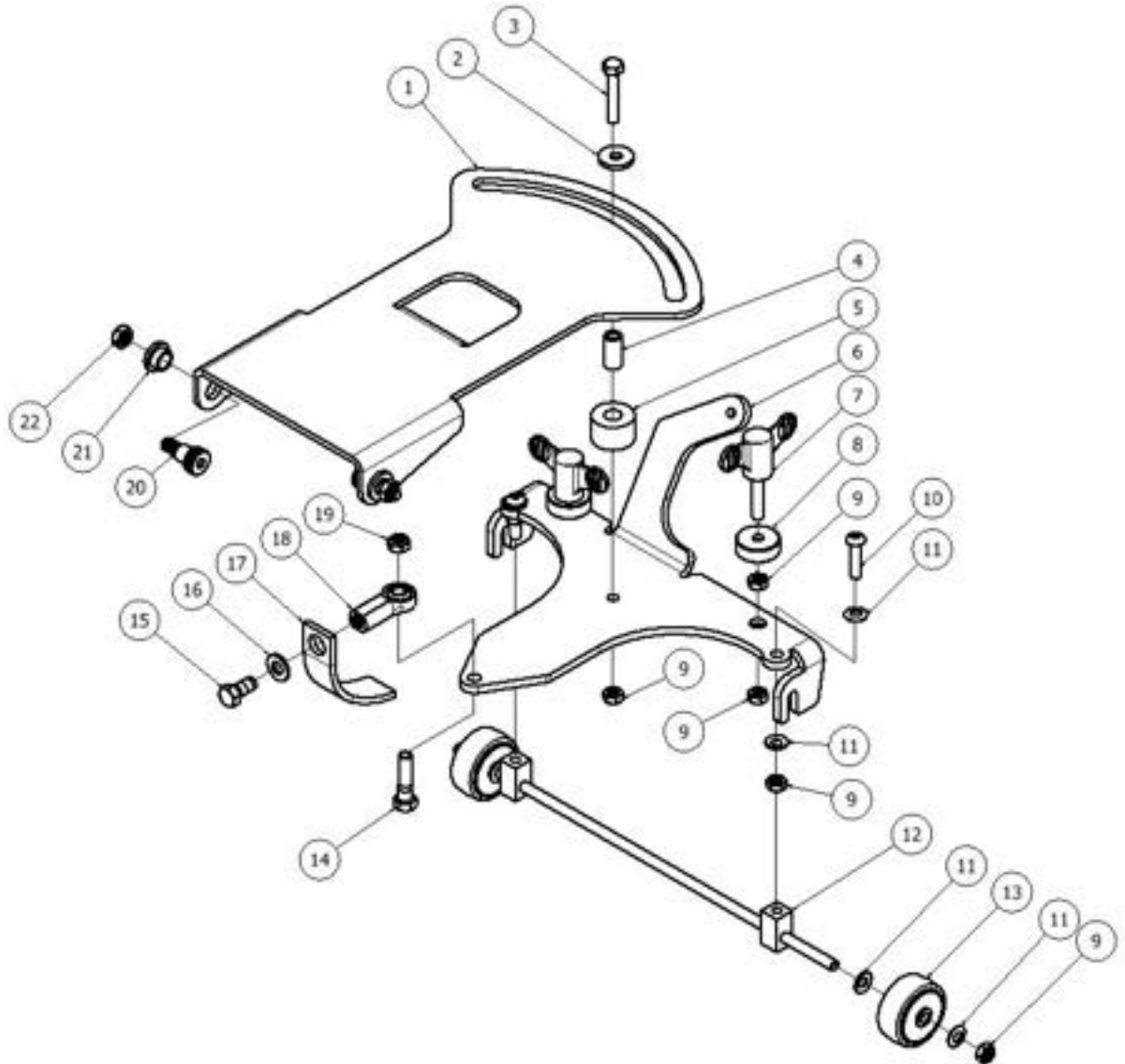

35" SQUEEGEE ASSEMBLY

ITEM	QTY	PART NUMBER	DESCRIPTION
1	1	877203	RETAINER REAR 35 INCH
2	1	870707	BLADE REAR 35 INCH URETHANE
2	1	870701	BLADE REAR 35 INCH LINATEX
3	3	962465	SCREW, SHOULDER, .50 X .50
4	2	980093	WASHER, WAVE, .50INCH
5	2	859703	WHEEL, GUIDE
6	1	873203	FRAME SQUEEGEE 35 INCH
7	3	920035	NUT, NYLOCK, .38-16, SS
8	1	870708	BLADE FRONT 35 INCH URETHANE
8	1	870702	BLADE FRONT 35 INCH LINARD
9	1	877204	RETAINER FRONT 35 INCH
10	2	852002	CLAMP, OVER-CENTER, BAND
11	4	920034	NUT, NYLOCK, #6-32, SS

Full Squeegee assemblies can be ordered under the following part numbers:

1. Linatex (standard): 878526
2. Urethane (optional): 878511



FRONT BLADE LENGTH: 37-1/2"
REAR BLADE LENGTH: 39-1/8"

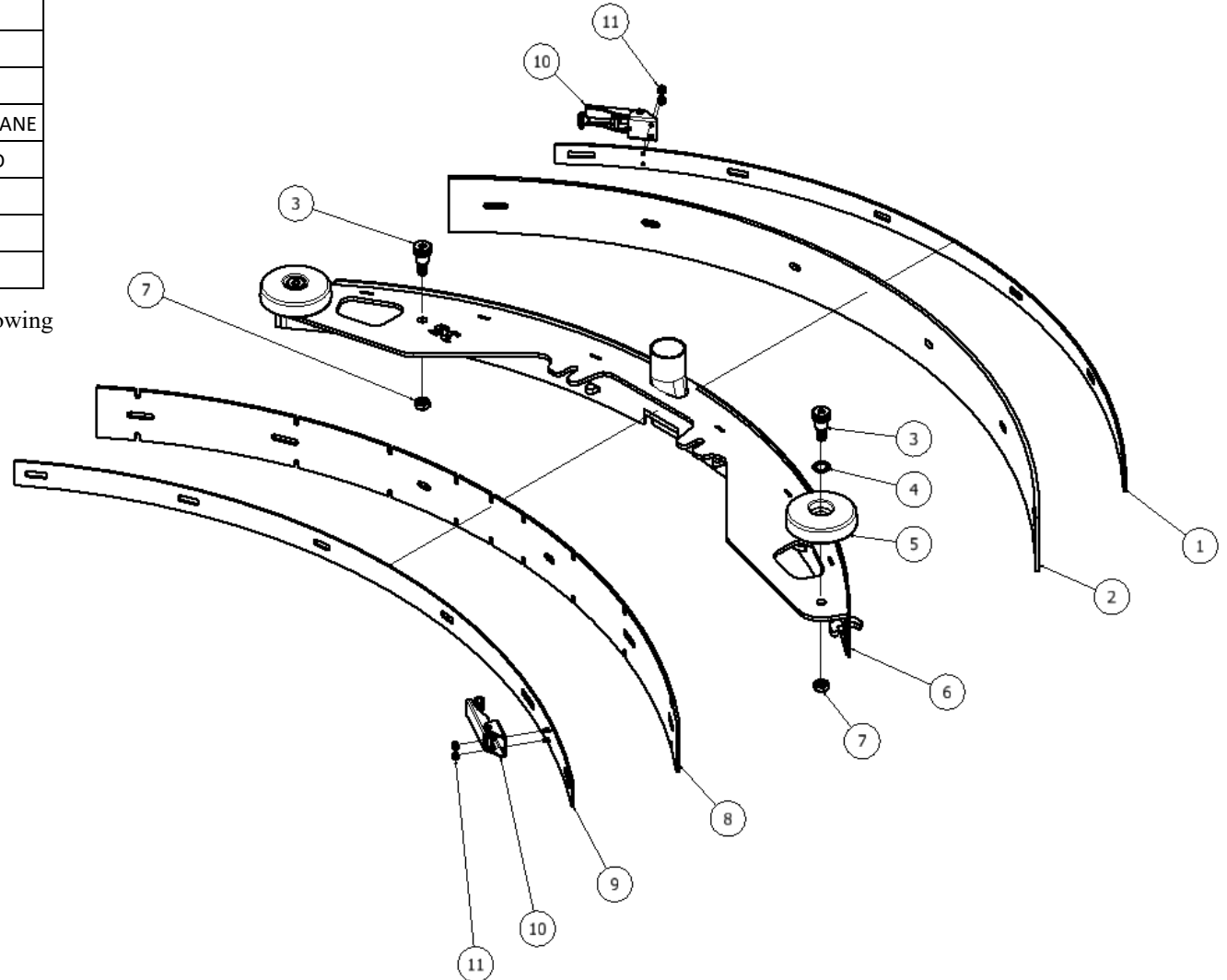

RETURN TO
TABLE OF
CONTENTS

40" SQUEEGEE ASSEMBLY

ITEM	QTY	PART NUMBER	DESCRIPTION
1	1	877201	RETAINER REAR 40 INCH
2	1	870709	BLADE REAR 40 INCH URETHANE
2	1	870703	BLADE REAR 40 INCH LINATEX
3	3	962465	SCREW, SHOULDER, .50 X .50
4	2	980093	WASHER, WAVE, .50INCH
5	2	859703	WHEEL, GUIDE
6	1	873204	FRAME SQUEEGEE 40 INCH
7	3	920035	NUT, NYLOCK, .38-16, SS
8	1	870710	BLADE FRONT 40 INCH URETHANE
8	1	870704	BLADE FRONT 40 INCH LINARD
9	1	877202	RETAINER FRONT 40 INCH
10	2	852002	CLAMP, OVER-CENTER, BAND
11	4	920034	NUT, NYLOCK, #6-32, SS

Full Squeegee assemblies can be ordered under the following part numbers:

1. Linatex (standard): 878527
2. Urethane (optional): 878512

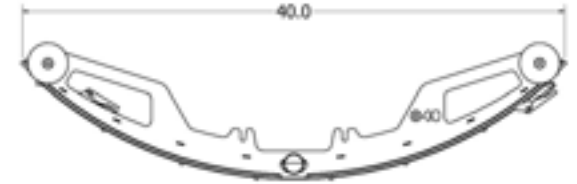

FRONT BLADE LENGTH: 43"
REAR BLADE LENGTH: 44-5/8"

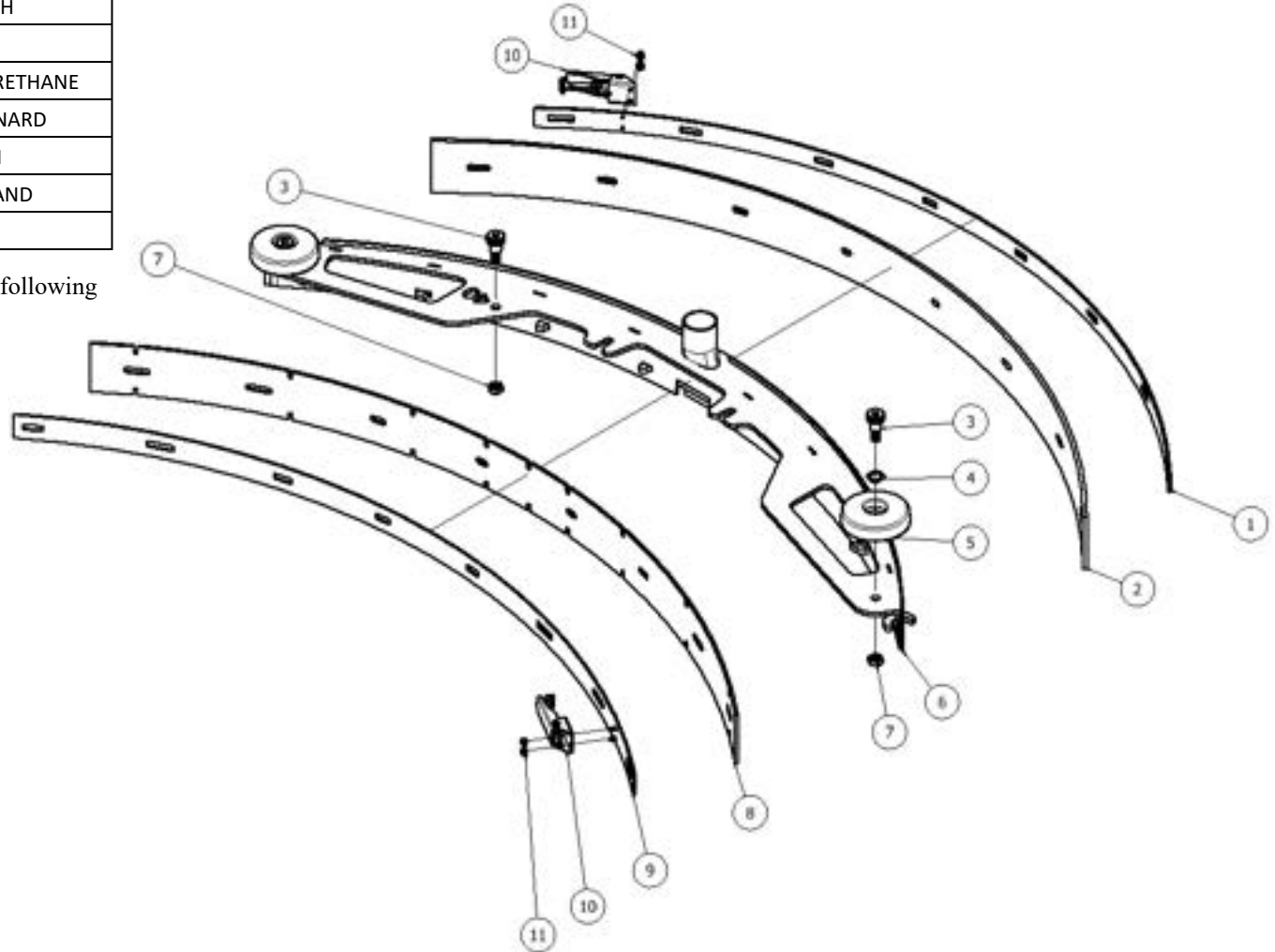

45" SQUEEGEE ASSEMBLY

ITEM	QTY	PART NUMBER	DESCRIPTION
1	1	877205	RETAINER REAR 45 INCH
2	1	870711	BLADE REAR 45 INCH URETHANE
2	1	870705	BLADE REAR 45 INCH LINATEX
3	3	962465	SCREW, SHOULDER, .50 X .50
4	2	980093	WASHER, WAVE, .50INCH
5	2	859703	WHEEL, GUIDE
6	1	873205	FRAME SQUEEGEE 45 INCH
7	3	920035	NUT, NYLOCK, .38-16, SS
8	1	870712	BLADE FRONT 45 INCH URETHANE
8	1	870706	BLADE FRONT 45 INCH LINARD
9	1	877206	RETAINER FRONT 45 INCH
10	2	852002	CLAMP, OVER-CENTER, BAND
11	4	920034	NUT, NYLOCK, #6-32, SS

Full Squeegee assemblies can be ordered under the following part numbers:

1. Linatex (standard): 878528
2. Urethane (optional): 878513



FRONT BLADE LENGTH: 47-1/8"
REAR BLADE LENGTH: 48-5/8"

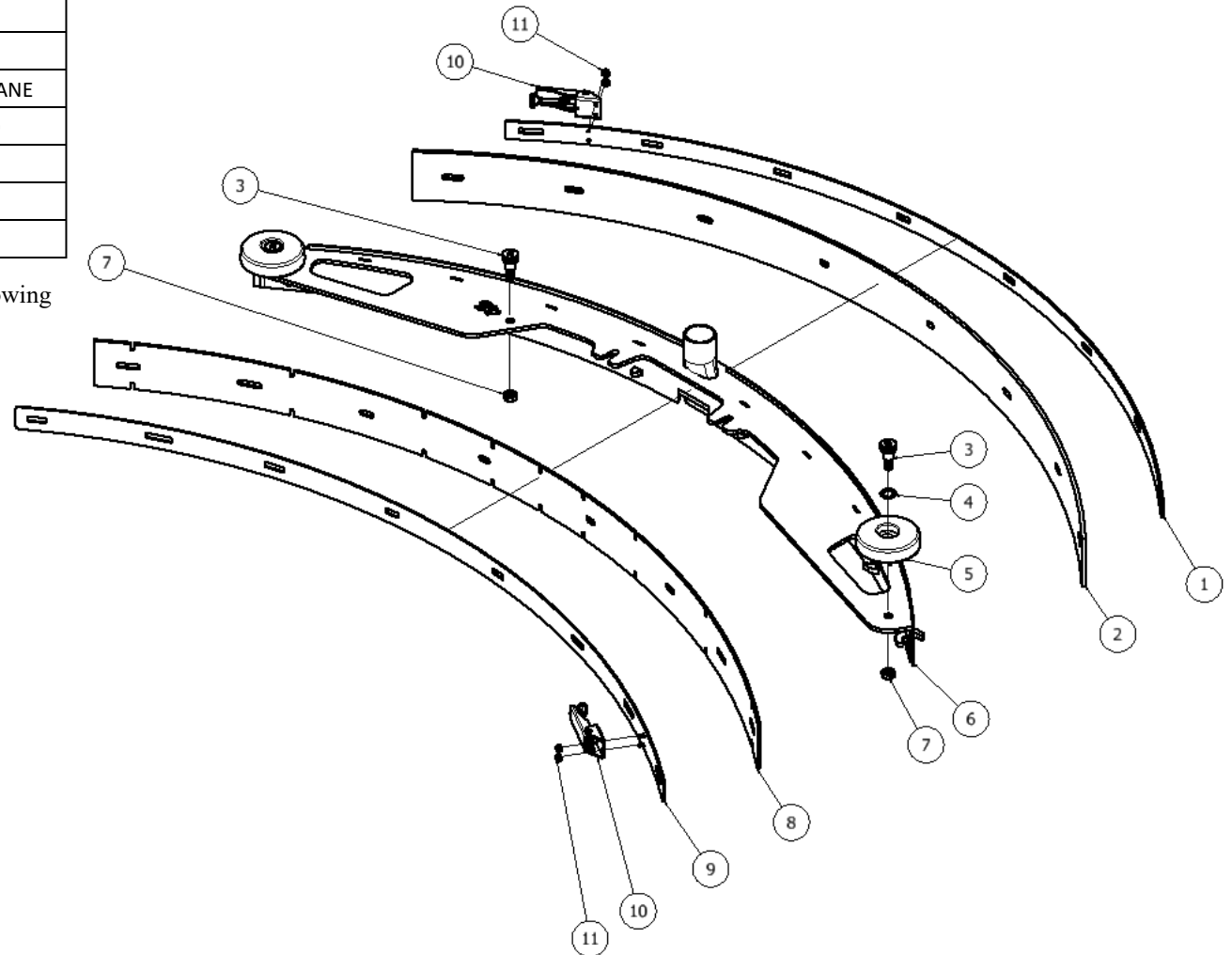

RETURN TO
TABLE OF
CONTENTS

S-24 DISK SCRUB HEAD

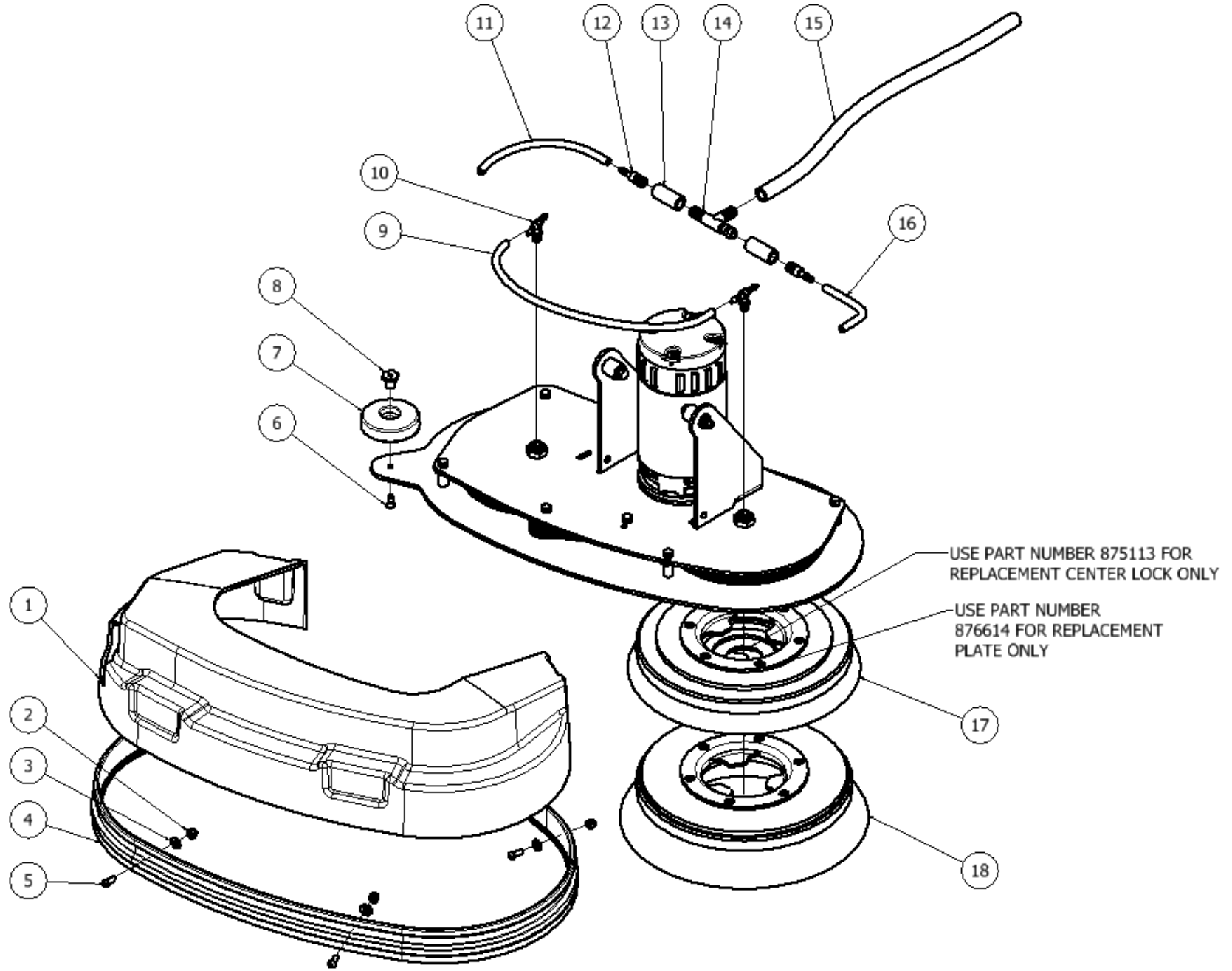

S-24 DISK SCRUB HEAD

ITEM	QTY	PART NUMBER	DESCRIPTION
1*	1	872305	SHROUD, HEAD, 24INCH
2*	4	920665	NUT, NYLOCK, 1/4-20, SS
3*	4	W104D	WASHER, FLAT, .25
4*	1	858503	SKIRT, BRISTLE
5*	4	962263	SCREW, BUTT, SOCK, .25-20X.62, SS BO
6	1	962274	SCREW, FLAT, SOCK, .25-20X.62, SS, PATCH
7	1	859703	WHEEL, GUIDE
8	1	878205	SPACER, WHEEL, GUIDE
9	1	204179 - 16.0"	TUBING, 1/4"
10	2	873302	FITTING, TEE, PM02XBM04
11	1	204179 - 8.25"	TUBING, 1/4"
12	2	853301	FITTING, REDUCER, BM08, BM04
13	2	224130 - 1.75"	TUBING, 1/2"
14	1	873308	FITTING, TEE, 0.50 INCH
15	1	224130 - 20.0"	TUBING, 1/2"
16	1	204179 - 9.75"	TUBING, 1/4"
17	2	875901	DRIVER, PAD, 12INCH, BRISTLE
18**	2	870902	BRUSH, POLY, 12 INCH
18**	2	870908	BRUSH, NYLON, 12 INCH
18**	2	870909	BRUSH, GRIT, 12 INCH

*Items 1-5 can be ordered as an assembly under part number 875019.

**Optional brushes (Item 18) listed for reference.

S-24 DISK SCRUB HEAD

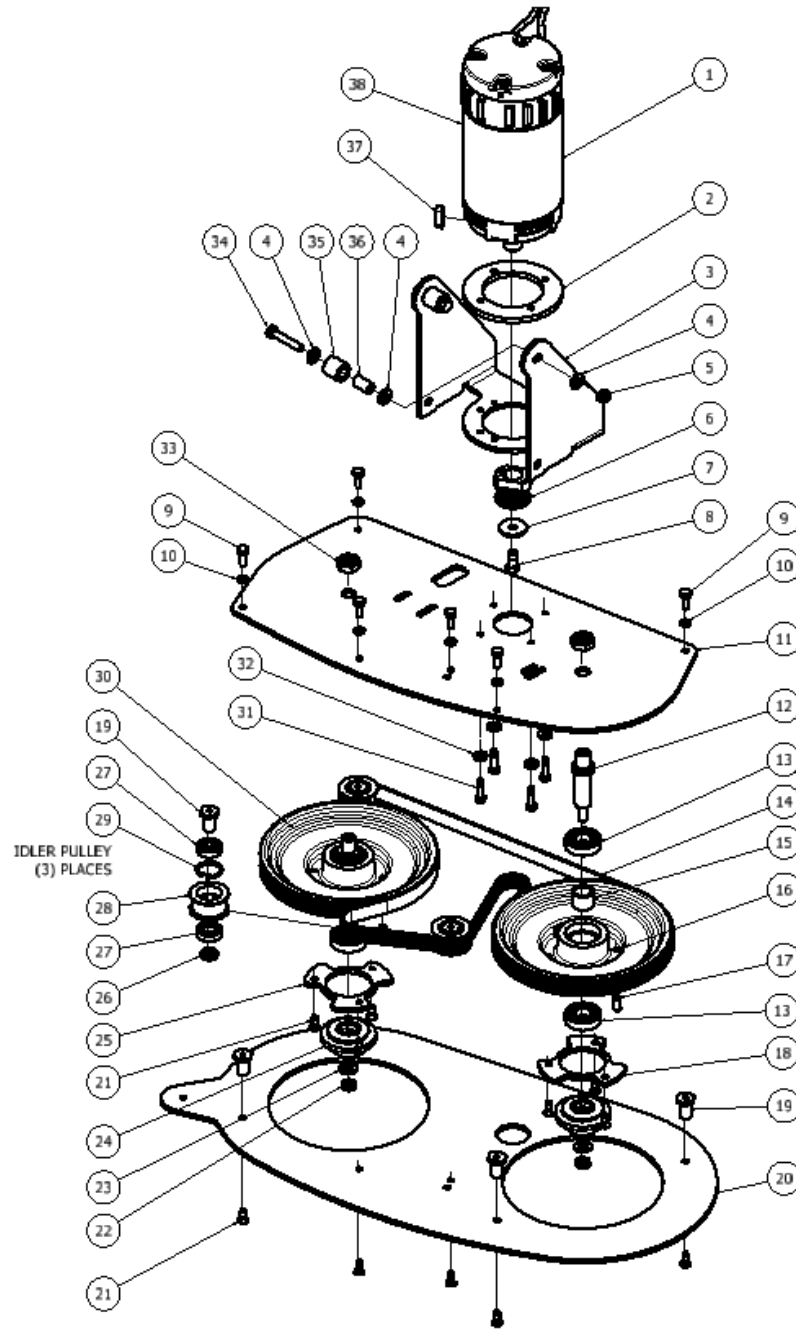

S-24 DISK SCRUB HEAD

ITEM	QTY	PART NUMBER	DESCRIPTION
1	1	855204	MOTOR, 24V, 2200 RPM, 1HP
2	1	878206	SPACER, MOTOR, 24INCH
3	1	870807	BRACKET, SUPPORT, HEAD 24
4	6	W243D	WASHER, FLAT, 5/16, SS
5	2	920012	NUT, NYLOCK, 5/16-18, ZINC
6	1	876902	PULLEY, MOTOR, DRIVE
7	1	980108	WASHER, FLAT, .31ID, 1.25OD, .12THK, SS
8	1	964060	SCREW, HEX, M8-1.25 X 20, SS
9	6	W189D	SCREW, HEX, 1/4-20 X .75, SS, PATCH
10	6	980002	WASHER, LOCK, SPLIT, .25
11	1	876602	PLATE, MTG, 24 INCH
12	2	877701	SHAFT, PULLEY, HEAD
13	4	902053	BEARING, .75 ID, DBL SEAL
14	1	903046	BELT, V-GROOVE, STRETCH
15	2	878203	SPACER, BEARING
16	1	874305	HUB, PULLEY, MACH FLAT
17	2	857009	PLUNGER BALL PRESS-IN
18	1	873802	GUIDE, DRIVER, RH
19	6	878201	SPACER, IDLER
20	1	876606	PLATE, COVER, 24 INCH
21	12	962274	SCREW, FLAT, SOCK, .25-20X.62, SS, PATCH
22	2	920035	NUT, NYLOCK, .38-16, SS
23	2	980003	WASHER, FLAT, .38
24	2	873801	GUIDE, PAD, PLASTIC
25	1	853803	GUIDE, DRIVER
26	3	878202	SPACER, IDLER, PLAIN
27	6	902035	BEARING, .5 ID, 1.1875 OD
28	3	876901	PULLEY, IDLER
29	3	877302	RING, RETAINING, INT, 1.12 DIA
30	1	874306	HUB, PULLEY, MACH GROOVED
31	4	964008	SCREW, HEX, M6 X 25, SS, PATCH

ITEM	QTY	PART NUMBER	DESCRIPTION
32	8	W104D	WASHER, FLAT, .25
33	2	920039	NUT, .62-18, NYLOCK, LOW
34	2	962270	SCREW, HEX, 5/16-18X1.75,SS
35	2	857501	ROLLER, PLASTIC
36	2	858203	SPACER, WHEEL, GUIDE
37	1	915006	KEY, 8MM X 7MM X 28MM
38	1	850906	BRUSH CARBON KIT 4 PC 855204 & 875201

S-28 DISK SCRUB HEAD

*** PRIOR TO SERIAL NUMBER 121567 – CONFIRM SERIAL NUMBER BEFORE ORDERING REPLACEMENT PARTS ***

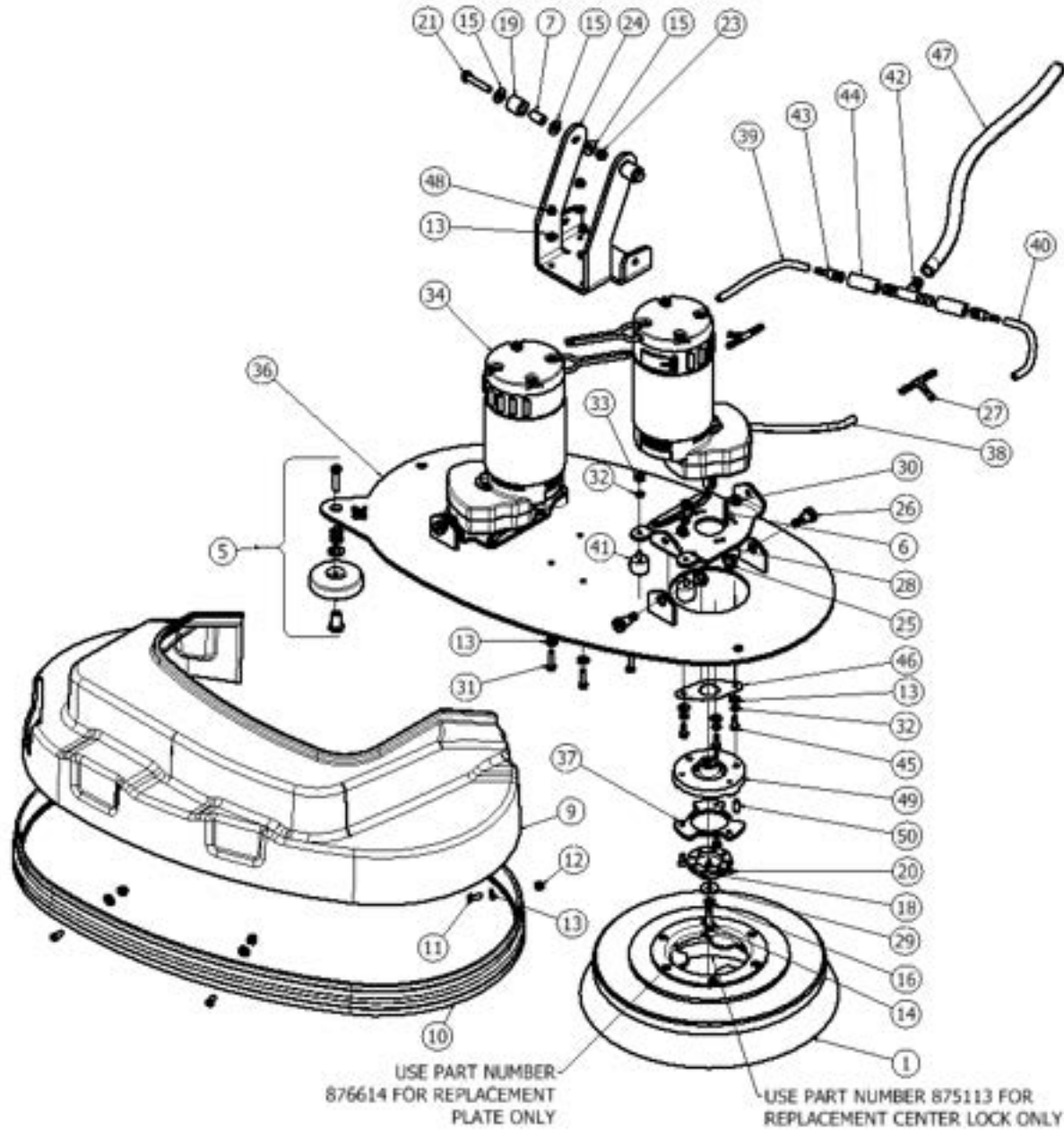

S-28 DISK SCRUB HEAD

***** PRIOR TO SERIAL NUMBER 121567 – CONFIRM SERIAL NUMBER BEFORE ORDERING REPLACEMENT PARTS *****

ITEM	QTY	PART NUMBER	DESCRIPTION
1**	2	870901	BRUSH, POLY, 14 INCH
1**	2	870904	BRUSH, NYLON, 14 INCH
1**	2	870906	BRUSH, GRIT, 14 INCH
1**	2	875902	DRIVER, PAD, 14 INCH
5	1	855022	KIT GUIDE WHEEL REPLACEMENT ANIT-RATTLE
6	2	915008	KEY, SQUARE, 5MM X 5 X 40MM
7	3	858203	SPACER, WHEEL, GUIDE
8	1	875020	KIT SHROUD S28 REPLACEMENT (ITEMS 9 - 13)
9	1	872302	SHROUD, HEAD, 28INCH
10	1	878502	SKIRT, BRISTLE
11	4	962263	SCREW, BUTT, SOCK, .25-20X.62, SS BO
12	4	920665	NUT, NYLOCK, 1/4-20, SS
13	20	W104D	WASHER, FLAT, .25
14	2	962466	SCREW, HEX, M8-1.25 X 25, SS, PATCH
15	6	W243D	WASHER, FLAT, 5/16, SS
16	2	980094	WASHER, SPLIT LOCK, .31, SS
17	1	853803	GUIDE, DRIVER
18	2	853804	GUIDE, PAD, PLASTIC
19	2	857501	ROLLER, PLASTIC
20	6	962274	SCREW, FLAT, SOCK, .25-20X.62, SS, PATCH
21	2	962270	SCREW, HEX, 5/16-18X1.75,SS
23	2	920012	NUT, NYLOCK, 5/16-18, ZINC
24	1	870804	BRACKET, SUPPORT, HEAD
25	4	871101	BUSHING, FLANGE, .50IN
26	4	962465	SCREW, SHOULDER, .50 X .50
27	2	873301	FITTING, TEE, .25INCH
28	2	876604	PLATE, MOUNTING, GIMBLE
29	2	980107	WASHER, FLAT, .31ID, 1.0OD, .12THK, SS
30	4	920035	NUT, NYLOCK, .38-16, SS
31	4	962221	SCREW, HEX, .25-20 X 1.0, SS

ITEM	QTY	PART NUMBER	DESCRIPTION
32	12	980002	WASHER, LOCK, SPLIT, .25
33	4	920037	NUT, THIN JAM, 1/4-20, ZINC
34	2	875203	MOTOR GEAR BRUSH MRP15 SERVICE
35	1	850906	BRUSH CARBON KIT 4 PC 855204 & 875201
36	1	876601	PLATE, MTG, 28INCH
37	1	873802	GUIDE, DRIVER, RH
38	1	204179 - 15.2"	TUBING, 1/4"
39	1	204179 - 6.0"	TUBING, 1/4"
40	1	204179 - 5.5"	TUBING, 1/4"
41	4	875603	BUMPER, RUBBER, WITH STUD
42	1	873308	FITTING, TEE, 0.50 INCH
43	2	853301	FITTING, REDUCER, BM08, BM04
44	2	224130 - 1.75"	TUBING, 1/2"
45	8	964448	SCREW, HEX, M6 X 16, SS, PATCH
46	2	870818	BRACKET, RETAINING, SEAL
47	1	224130 - 20.0"	TUBING, 1/2"
48	4	920011	NUT, NYLOCK, 1/4-20, ZINC
49	2	854302	HUB, DRIVER, BRUSH
50	2	857009	PLUNGER BALL PRESS-IN

*Items 9–13 can be ordered as an assembly under part number 875020.

**Optional brushes (Item 1) listed for reference.

S-28 DISK SCRUB HEAD

*** AFTER SERIAL NUMBER 121566 – CONFIRM SERIAL NUMBER BEFORE ORDERING REPLACEMENT PARTS ***

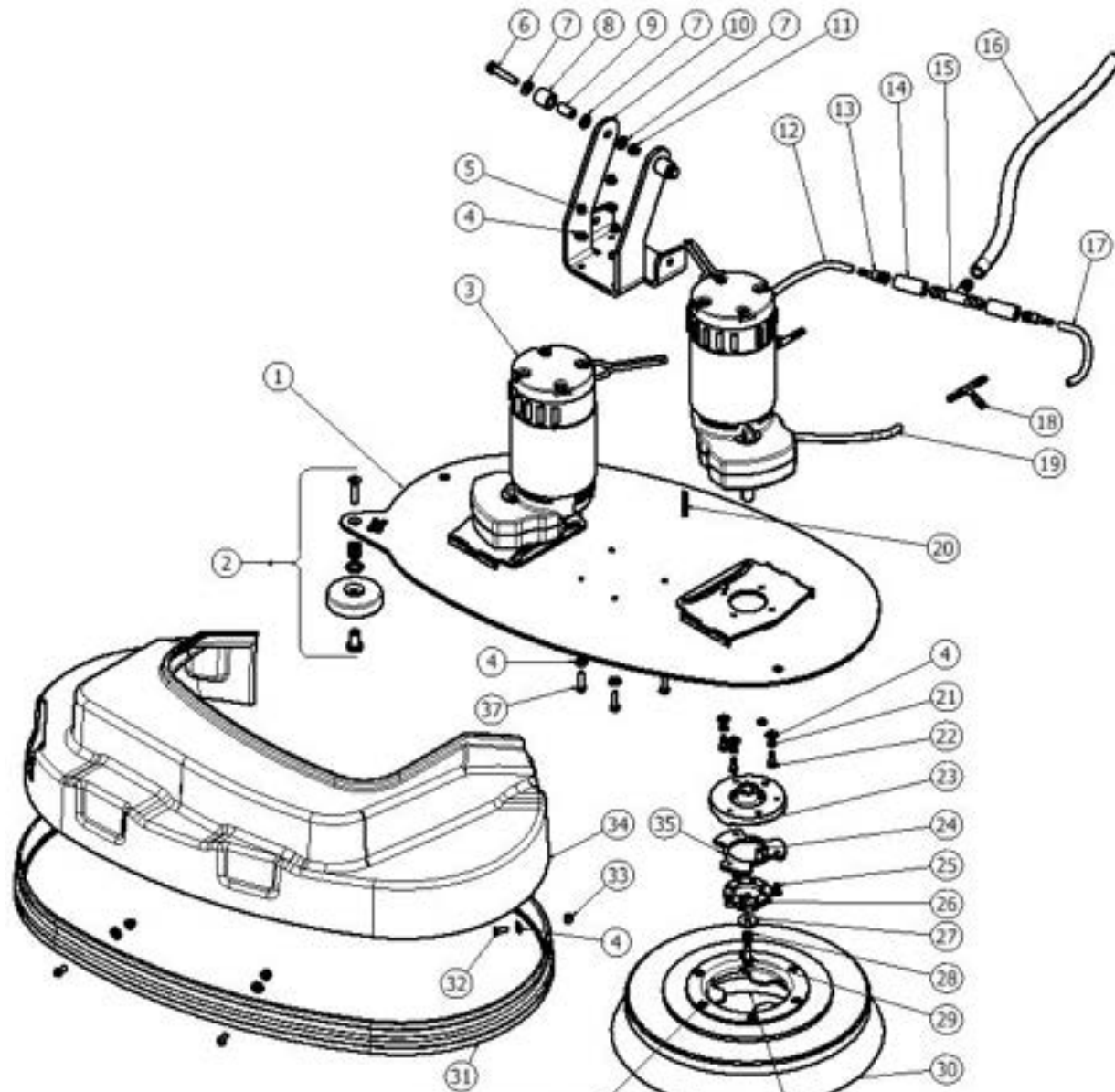

USE PART NUMBER
876614 FOR REPLACEMENT
PLATE ONLY

USE PART NUMBER 875113 FOR
REPLACEMENT CENTER LOCK ONLY

S-28 DISK SCRUB HEAD

***** AFTER SERIAL NUMBER 121566 – CONFIRM SERIAL NUMBER BEFORE ORDERING REPLACEMENT PARTS *****

ITEM	QTY	PART NUMBER	DESCRIPTION
1	1	876612	PLATE, MTG, 28INCH, TORNADO
2	1	855022	KIT WHEEL GUIDE REPLACEMENT
3	2	875203	MOTOR GEAR BRUSH MRP15 SERVICE
4*	20	W104D	WASHER, FLAT, .25
5	4	920011	NUT, NYLOCK, 1/4-20, ZINC
6	2	962270	SCREW, HEX, 5/16-18X1.75,SS
7	6	W243D	WASHER, FLAT, 5/16, SS
8	2	857501	ROLLER, PLASTIC
9	2	858203	SPACER, WHEEL, GUIDE
10	1	870804	BRACKET, SUPPORT, HEAD
11	2	920012	NUT, NYLOCK, 5/16-18, ZINC
12	1	204179 - 6.0"	TUBING, 1/4"
13	2	853301	FITTING, REDUCER, BM08, BM04
14	2	224130 - 1.75"	TUBING, 1/2"
15	1	873308	FITTING, TEE, 0.50 INCH
16	1	224130 - 20.0"	TUBING, 1/2"
17	1	204179 - 5.5"	TUBING, 1/4"
18	2	873301	FITTING, TEE, .25INCH
19	1	204179 - 15.2"	TUBING, 1/4"
20	2	915008	KEY, SQUARE, 5MM X 5 X 40MM
21	8	980002	WASHER, LOCK, SPLIT, .25
22	8	964448	SCREW, HEX, M6 X 16, SS, PATCH
23	2	854302	HUB, DRIVER, BRUSH
24	2	857009	PLUNGER BALL PRESS-IN
25	6	962274	SCREW, FLAT, SOCK, .25-20X.62, SS, PATCH
26	2	853804	GUIDE, PAD, PLASTIC
27	2	980107	WASHER, FLAT, .31ID, 1.0OD, .12THK, SS
28	2	980094	WASHER, SPLIT LOCK, .31, SS
29	2	962466	SCREW, HEX, M8-1.25 X 25, SS, PATCH
30	2	870901	BRUSH, POLY, 14 INCH

ITEM	QTY	PART NUMBER	DESCRIPTION
31*	1	878502	SKIRT, BRISTLE
32*	4	962263	SCREW, BUTT, SOCK, .25-20X.62, SS BO
33*	4	920665	NUT, NYLOCK, 1/4-20, SS
34*	1	872302	SHROUD, HEAD, 28INCH
35	1	873802	GUIDE, DRIVER, RH
36	1	853803	GUIDE, DRIVER, LH (NOT SHOWN)
37	4	962221	SCREW, HEX, .25-20 X 1.0, SS
38	1	875020	ASSY SHROUD S28 REPLACEMENT (ITEMS 31-34 & 4)
39	1	850906	BRUSH CARBON KIT 4 PC 855204 & 875201

*Items 31–34, & 4 can be ordered as an assembly under part number 875020.

S-32 DISK SCRUB HEAD

*** PRIOR TO SERIAL NUMBER 121567 – CONFIRM SERIAL NUMBER BEFORE ORDERING REPLACEMENT PARTS ***

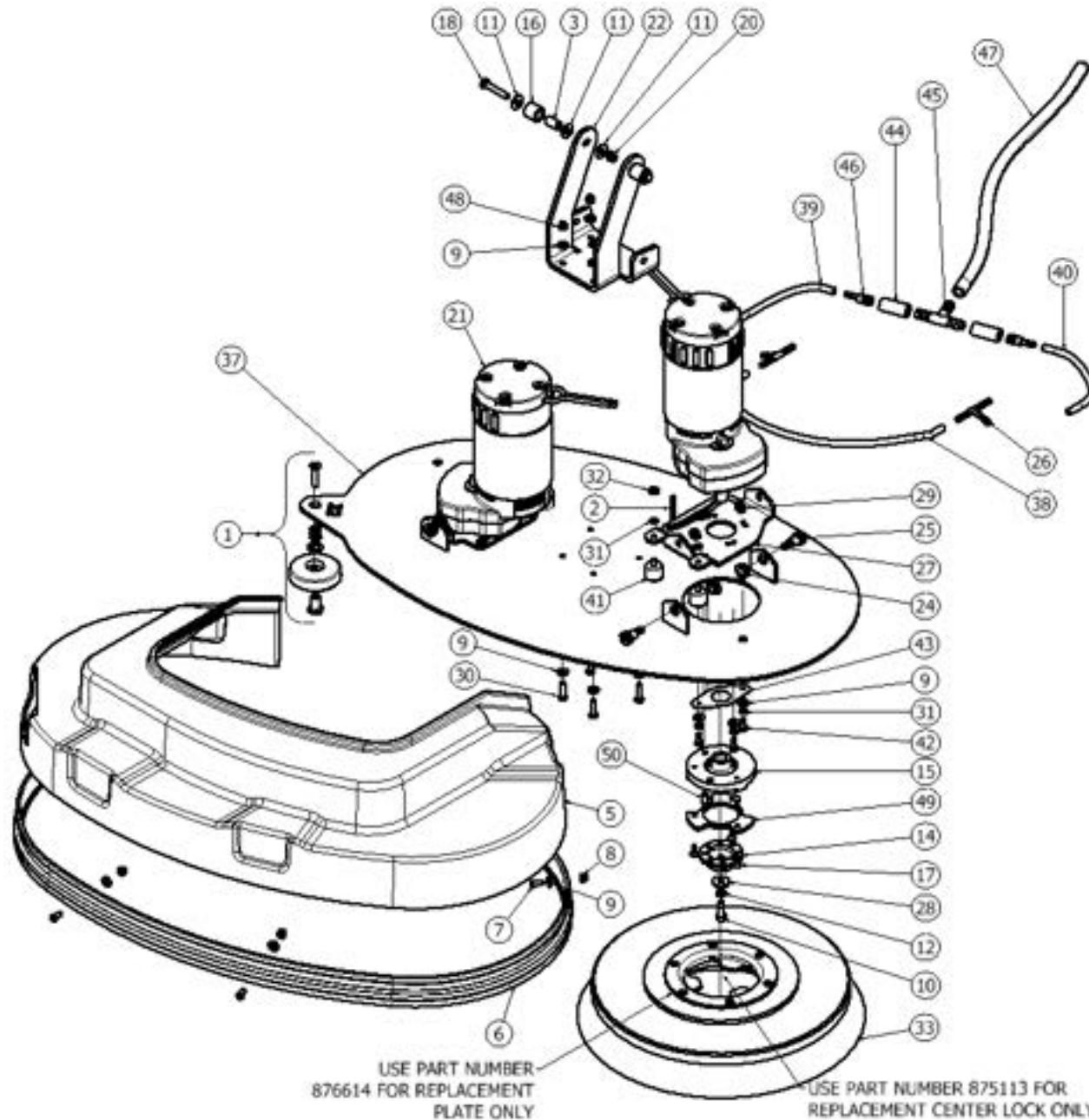

S-32 DISK SCRUB HEAD

***** PRIOR TO SERIAL NUMBER 121567 – CONFIRM SERIAL NUMBER BEFORE ORDERING REPLACEMENT PARTS *****

ITEM	QTY	PART NUMBER	DESCRIPTION
1	1	855022	KIT GUIDE WHEEL RELACEMENT ANTI-RATTLE
2	2	915008	KEY, SQUARE, 5MM X 5 X 40MM
3	2	858203	SPACER, WHEEL, GUIDE
4	1	875021	KIT SHROUD S32 REPLACEMENT (ITEMS 4 - 8)
5	1	872306	SHROUD, HEAD, 32INCH
6	1	878502	SKIRT, BRISTLE
7	4	962263	SCREW, BUTT, SOCK, .25-20X.62, SS BO
8	4	920665	NUT, NYLOCK, 1/4-20, SS
9	20	W104D	WASHER, FLAT, .25
10	2	962466	SCREW, HEX, M8-1.25 X 25, SS, PATCH
11	6	W243D	WASHER, FLAT, 5/16, SS
12	2	980094	WASHER, SPLIT LOCK, .31, SS
13	1	853803	GUIDE, DRIVER
14	2	853804	GUIDE, PAD, PLASTIC
15	2	854302	HUB, DRIVER, BRUSH
16	2	857501	ROLLER, PLASTIC
17	6	962274	SCREW, FLAT, SOCK, .25-20X.62, SS, PATCH
18	2	962270	SCREW, HEX, 5/16-18X1.75,SS
20	2	920012	NUT, NYLOCK, 5/16-18, ZINC
21	2	875203	MOTOR GEAR BRUSH MRP15 SERVICE
22	1	870804	BRACKET, SUPPORT, HEAD
23	1	850906	BRUSH CARBON KIT 4 PC 855204 & 875201
24	4	871101	BUSHING, FLANGE, .50IN
25	4	962465	SCREW, SHOULDER, .50 X .50
26	2	873301	FITTING, TEE, .25INCH
27	2	876604	PLATE, MOUNTING, GIMBLE
28	2	980107	WASHER, FLAT, .31ID, 1.0OD, .12THK, SS
29	4	920035	NUT, NYLOCK, .38-16, SS
30	4	962221	SCREW, HEX, .25-20 X 1.0, SS
31	12	980002	WASHER, LOCK, SPLIT, .25
32	4	920037	NUT, THIN JAM, 1/4-20, ZINC
33	2	870903	BRUSH, POLY, 16 INCH
33	2	870905	BRUSH, NYLON, 16 INCH
33	2	870907	BRUSH, GRIT, 16 INCH
33	2	875910	DRIVER, PAD, 16 INCH

ITEM	QTY	PART NUMBER	DESCRIPTION
37	1	876603	PLATE, MTG, 32INCH
38	1	204179 - 17.2"	TUBING, 1/4"
39	1	204179 - 7.0"	TUBING, 1/4"
40	1	204179 - 6.5"	TUBING, 1/4"
41	4	875603	BUMPER, RUBBER, WITH STUD
42	8	964448	SCREW, HEX, M6 X 16, SS, PATCH
43	2	870818	BRACKET, RETAINING, SEAL
44	2	224130 - 1.75"	TUBING, 1/2"
45	1	873308	FITTING, TEE, 0.50 INCH
46	2	853301	FITTING, REDUCER, BM08, BM04
47	1	224130 - 20.0"	TUBING, 1/2"
48	4	920011	NUT, NYLOCK, 1/4-20, ZINC
49	1	873802	GUIDE DRIVER RH
49	1	853803	GUIDE DRIVER LH
50	2	857009	PLUNGER BALL PRESS-IN

S-32 DISK SCRUB HEAD

*** AFTER SERIAL NUMBER 121566 – CONFIRM SERIAL NUMBER BEFORE ORDERING REPLACEMENT PARTS ***

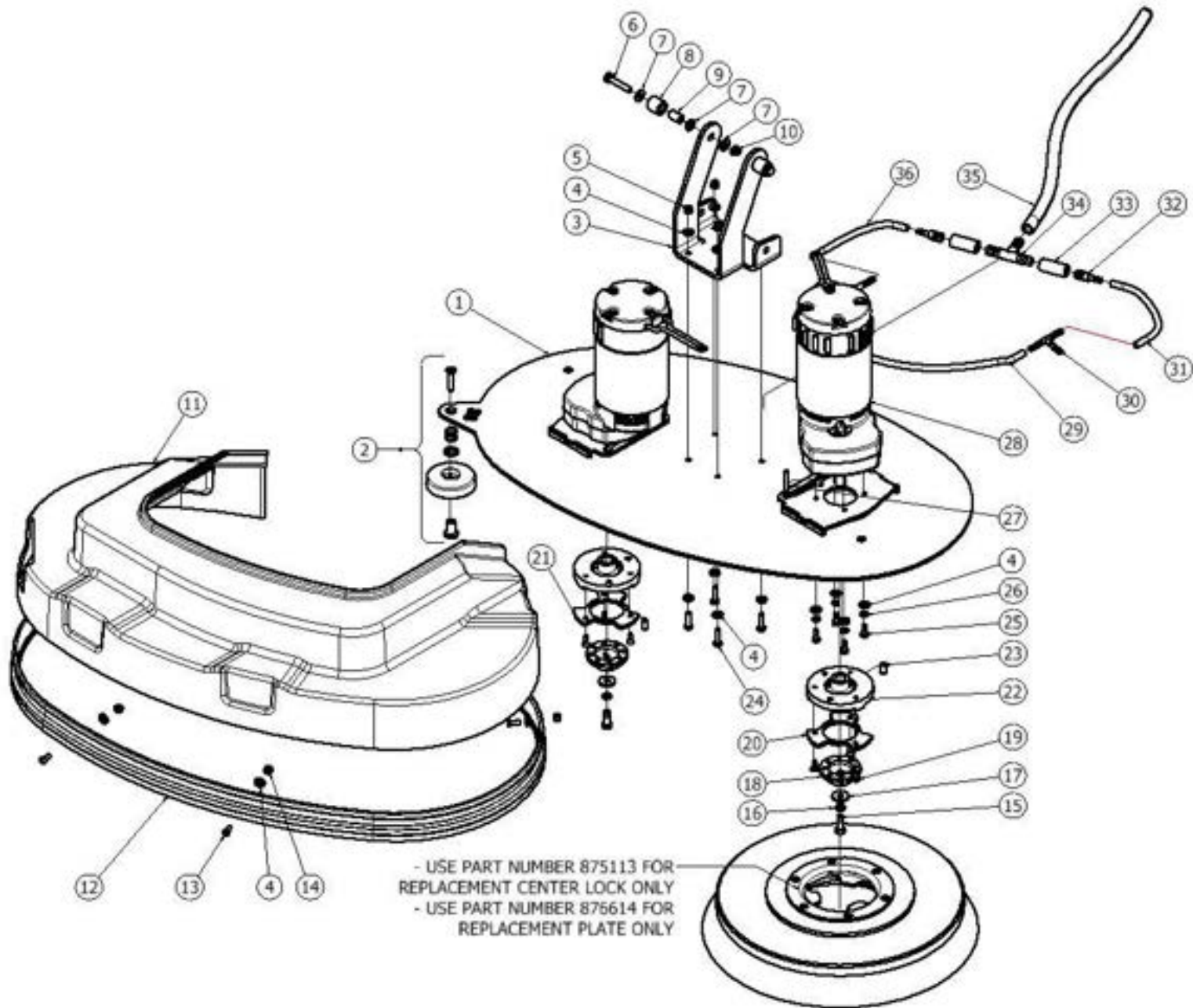

S-32 DISK SCRUB HEAD

***** AFTER SERIAL NUMBER 121566 – CONFIRM SERIAL NUMBER BEFORE ORDERING REPLACEMENT PARTS *****

ITEM	QTY	PART NUMBER	DESCRIPTION
1	1	876613	PLATE, MTG, 32INCH, RIGID
2	1	855022	KIT GUIDE WHEEL REPL ANTI-RATTLE
3	1	870804	BRACKET, SUPPORT, HEAD
4	20	W104D	WASHER, FLAT, .25
5	4	920011	NUT, NYLOCK, 1/4-20, ZINC
6	2	962270	SCREW, HEX, 5/16-18X1.75,SS
7	6	W243D	WASHER, FLAT, 5/16, SS
8	2	857501	ROLLER, PLASTIC
9	2	858203	SPACER, WHEEL, GUIDE
10	2	920012	NUT, NYLOCK, 5/16-18, ZINC
11	1	872306	SHROUD, HEAD, 32INCH
12	1	878502	SKIRT, BRISTLE
13	4	962263	SCREW, BUTT, SOCK, .25-20X.62, SS BO
14	4	920665	NUT, NYLOCK, 1/4-20, SS
15	2	962466	SCREW, HEX, M8-1.25 X 25, SS, PATCH
16	2	980094	WASHER, SPLIT LOCK, .31, SS
17	2	980107	WASHER, FLAT, .31ID, 1.00D, .12THK, SS
18	2	853804	GUIDE, PAD, PLASTIC
19	6	962274	SCREW, FLAT, SOCK, .25-20X.62, SS, PATCH
20	1	873802	GUIDE, DRIVER, RH
21	1	853803	GUIDE, DRIVER, LH
22	2	854302	HUB, DRIVER, BRUSH
23	2	857009	PLUNGER BALL PRESS-IN
24	4	962221	SCREW, HEX, .25-20 X 1.0, SS
25	8	964448	SCREW, HEX, M6 X 16, SS, PATCH
26	8	980002	WASHER, LOCK, SPLIT, .25
27	2	915008	KEY, SQUARE, 5MM X 5 X 40MM
28	2	875203	MOTOR GEAR BRUSH MRP15 SERVICE
29	1	204179 - 17.2"	TUBING, 1/4"
30	2	873301	FITTING, TEE, .25INCH
31	1	204179 - 6.5"	TUBING, 1/4"

ITEM	QTY	PART NUMBER	DESCRIPTION
32	2	853301	FITTING, REDUCER, BM08, BM04
33	2	224130 - 1.75"	TUBING, 1/2"
34	1	873308	FITTING, TEE, 0.50 INCH
35	1	224130 - 20.0"	TUBING, 1/2"
36	1	204179 - 7.0"	TUBING, 1/4"
37	1	875021	ASSY SHROUD S32 REPLACEMENT (ITEMS 11 - 14, & 4)
38	1	850906	BRUSH CARBON KIT 4 PC 855204 & 875201

*Items 11–14, & 4 can be ordered as an assembly under part number 875021.

S-28 ORBITAL SCRUB HEAD

ITEM	QTY	PART NUMBER	DESCRIPTION
1	1	870812	BRACKET, MTG, HEAD, ORBITAL
2	8	W104D	WASHER, FLAT, .25
3	4	962221	SCREW, HEX, .25-20 X 1.0, SS
4	1	853301	FITTING, REDUCER, BM08, BM04
5	10	920665	NUT, NYLOCK, 1/4-20, SS
6	2	856802	PLUG .62 TUBE
7	4	858205	SPACER, RUBBER
8	4	W405D	NUT, .31-18, JAM, SS
9	4	980094	WASHER, SPLIT LOCK, .31, SS
10	1	876609	PLATE, MOUNTING, MOTOR
11	8	851101	BUSHING, RUBBER
12	8	980104	WASHER, RUBBER
13	4	W117D	SCREW, HEX, .25-20 X 2.0, SS
14	4	964009	SCREW, SCK, FLT, M6-1 X 20, SS, PATCH
15	1	879005	TUBE DISTRIBUTION S-28 ORB
16	2	852003	CLAMP, P-SHAPED, .62 DIA
17	1	855116	LABEL PATENT ORBITAL HEAD
18	1	204179	TUBING, 1/4"
19	2	962263	SCREW, BUTT, SOCK, .25-20X.62, SS BO
20	2	855022	KIT GUIDE WHEEL REPLACEMENT ANTI-RATTLE
21	1	870813	BRACKET, SUPPORT, HEAD
22	2	920012	NUT, NYLOCK, 5/16-18, ZINC
23	6	W243D	WASHER, FLAT, 5/16, SS
24	2	857501	ROLLER, PLASTIC
25	2	858203	SPACER, WHEEL, GUIDE
26	2	980093	WASHER, WAVE, .50INCH
27	2	962270	SCREW, HEX, 5/16-18X1.75,SS
28	1	915006	KEY, 8MM X 7MM X 28MM
29	1	875205	MOTOR ORBITAL SERVICE
30	1	850906	BRUSH CARBON KIT 4 PC 855204 & 875201

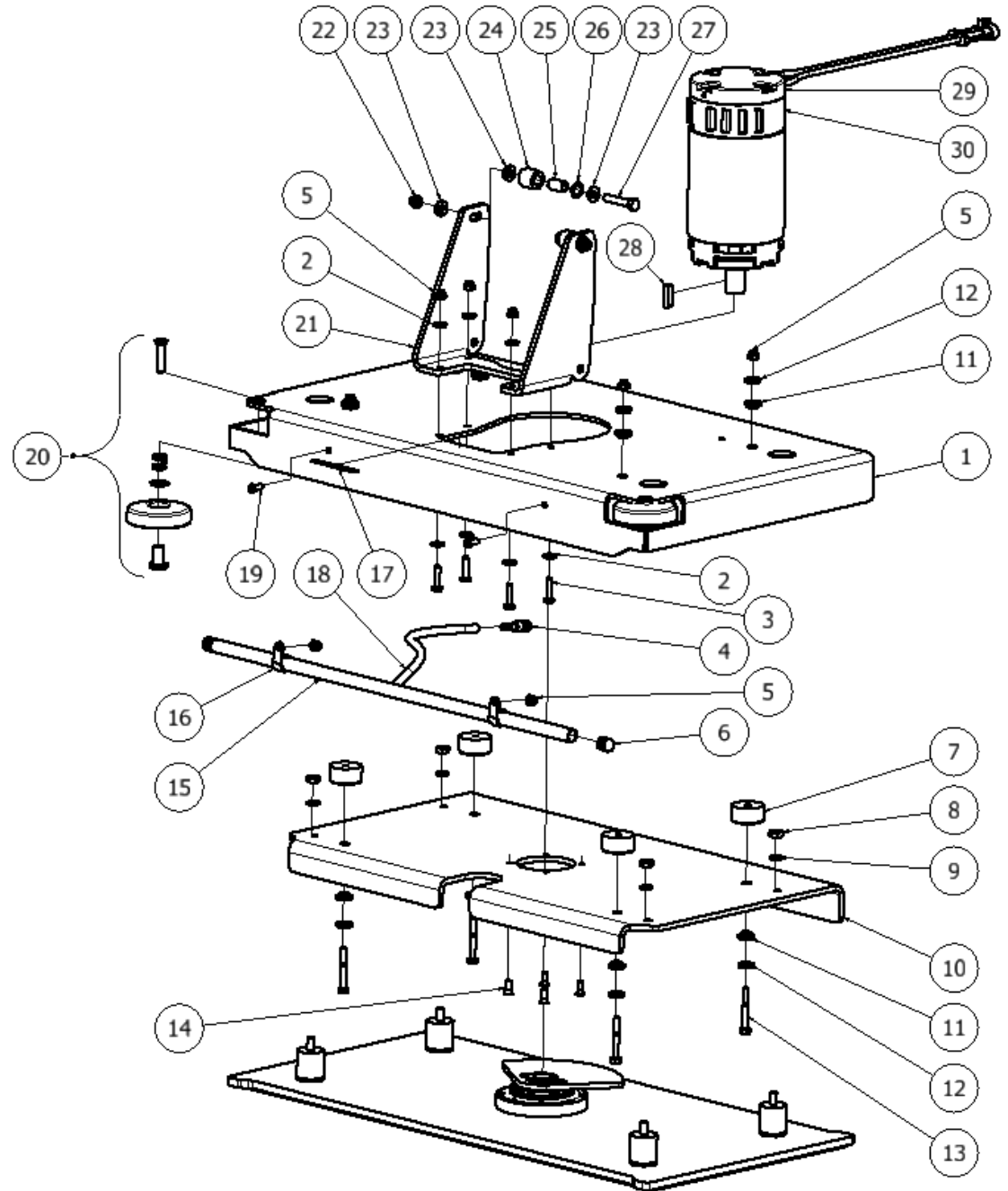

RETURN TO
TABLE OF
CONTENTS

S-28 ORBITAL SCRUB HEAD

ITEM	QTY	PART NUMBER	DESCRIPTION
1*	1	876607	PLATE, ORBITAL, 28 INCH
2*	1	875903	PAD, MIGHTYLOK ADH UNIVERSAL
3**	12	962278	SCREW, SOCKET, FLT, .31-18X.88, SS, PATCH
4**	4	980108	WASHER, FLAT, .31ID, 1.25OD, .12THK, SS
5**	4	855604	MOUNT, ISOLATOR, .31THD
6***	1	964447	SCREW, FLT, M8 X 16, SS
7***	1	875801	O-RING, EPDM, 233
8***	4	962274	SCREW, FLAT, SOCK, .25-20X.62, SS, PATCH
9***	1	876611	PLATE, RETAINING, BEARING
10***	1	N/A	ASSY, BEARING, REPL, ORBIT
11***	1	547604	SEAL BEARING ORBITAL
12	1	876608	PLATE, BALANCE, 28 INCH

*ITEMS 1 & 2 CAN BE ORDERED PRE-ASSEMBLED AS A KIT UNDER PART NUMBER 875009 - KIT, PLATE, REPL, ORBIT.

**ITEMS 3, 4, & 5 CAN BE ORDERED AS A KIT UNDER PART NUMBER 855027 - KIT ISOLATOR SET OF 4 W/ STD HWD.

***ITEMS 6-11 CAN BE ORDERED AS A KIT UNDER PART NUMBER 875010 - ASSY, BEARING, REPL, ORBIT.

NOTE: PRIOR TO SERIAL NUMBER 125673, SEAL (ITEM 11) WAS NOT PROVIDED. SEAL CAN BE ADDED WHEN THE BEARING ASSEMBLY IS REPLACED.

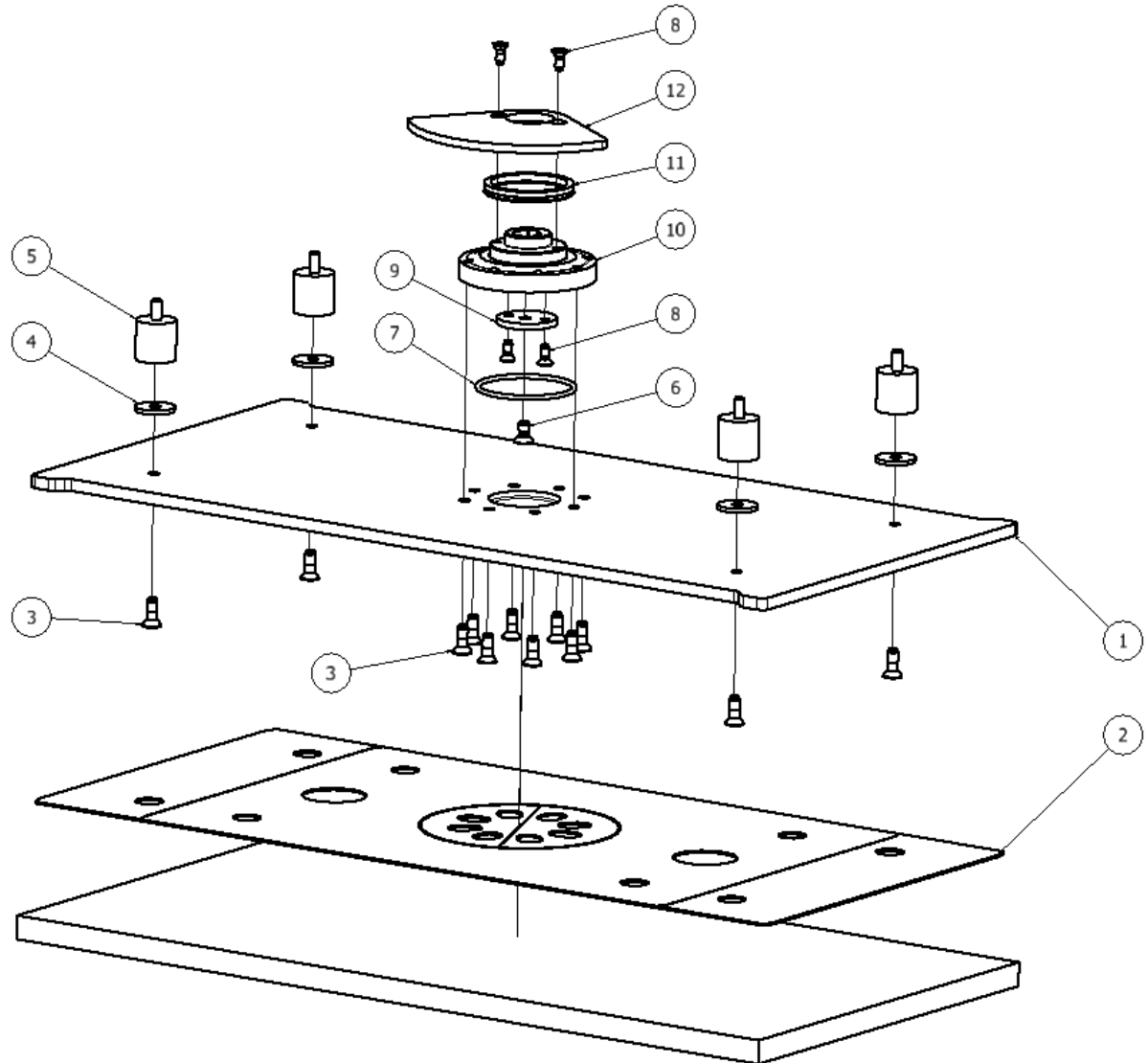

S-24 DISK

ALL SERIAL NUMBERS

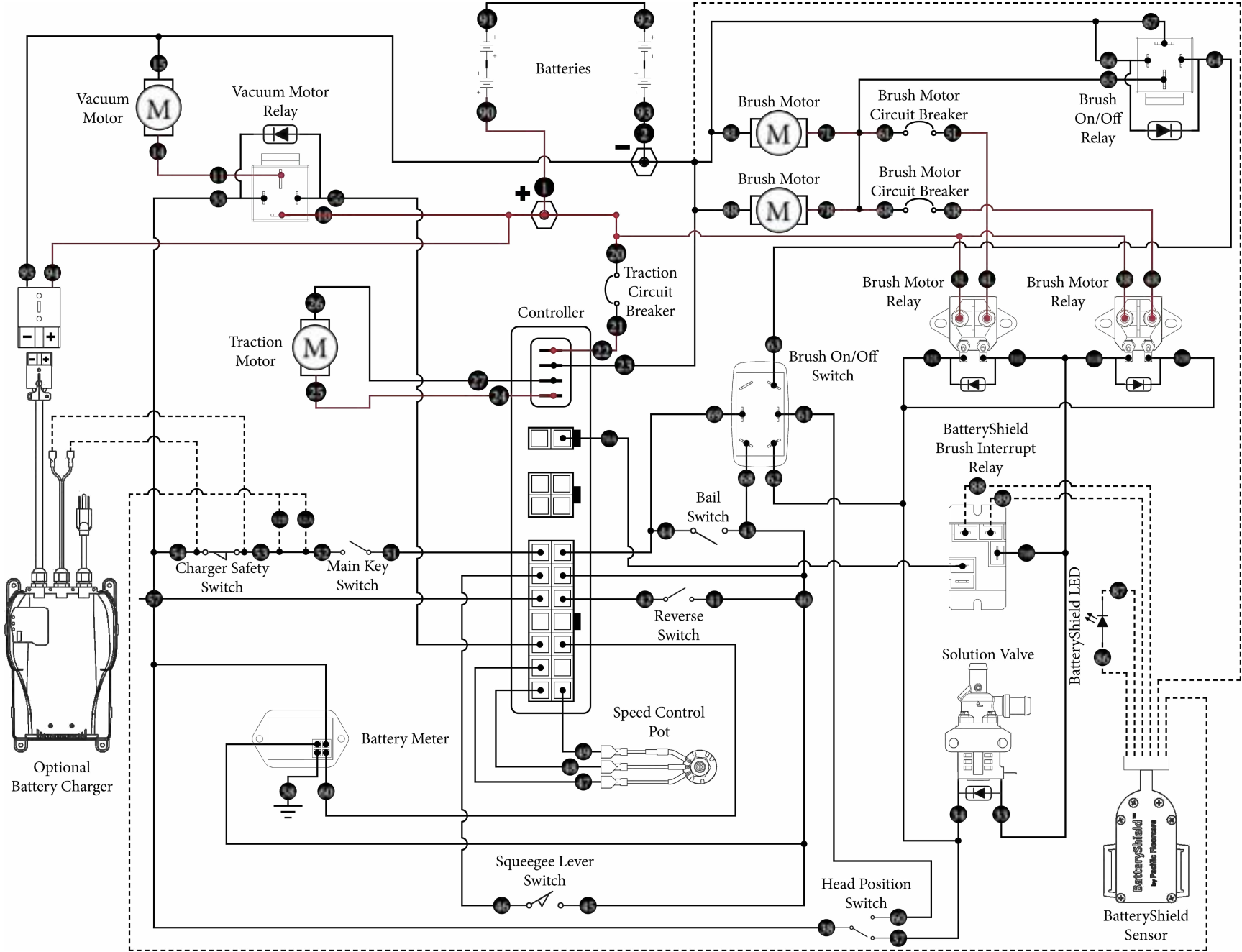

----- Wires represented with dashed lines indicate optional equipment installation

RETURN TO
TABLE OF
CONTENTS

PAGE INTENTIONALLY BLANK

S-28 & S-32 DISK ***PRIOR TO SERIAL NUMBER 113191***

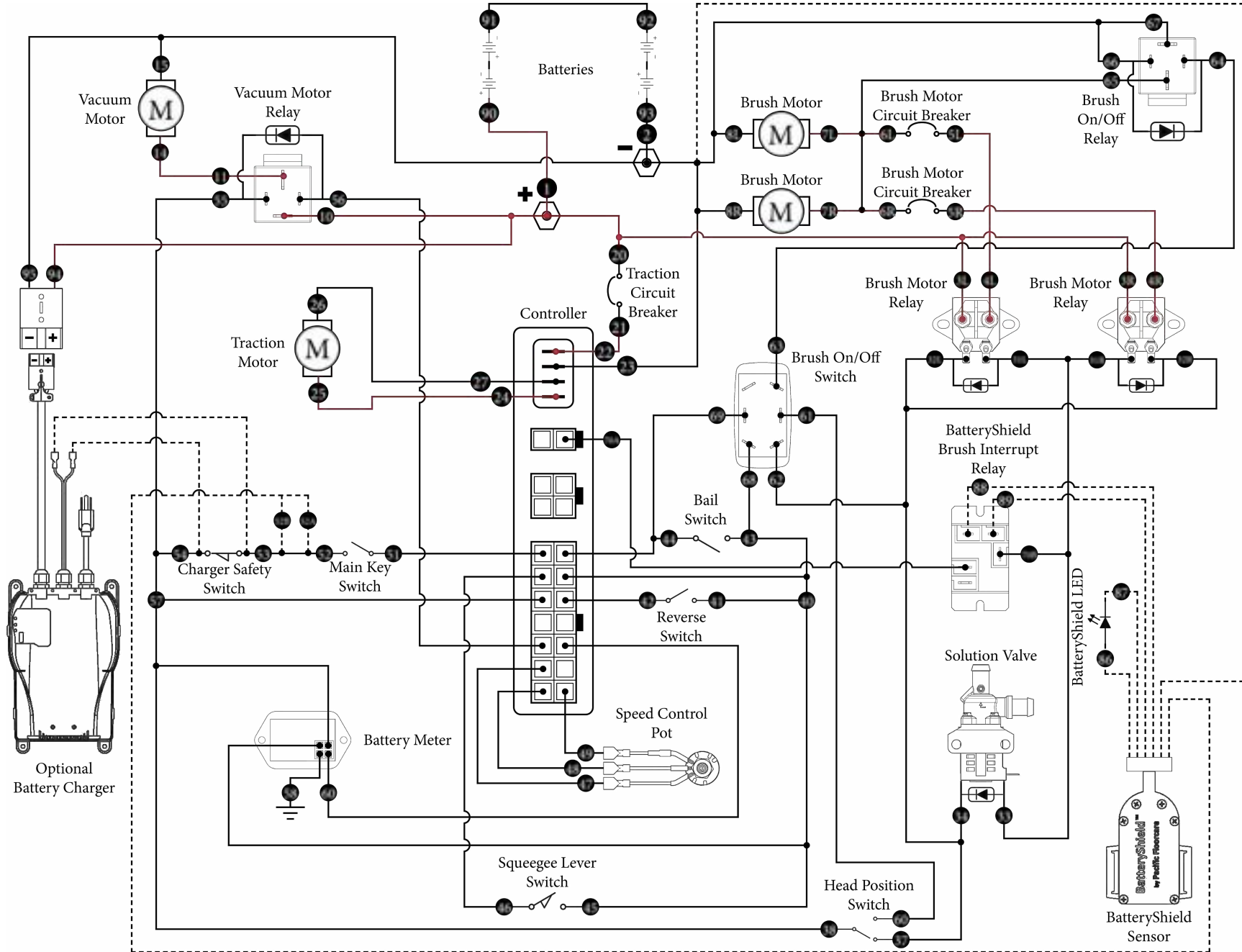

--- Wires represented with dashed lines indicate optional equipment installation

RETURN TO
TABLE OF
CONTENTS

S-28 & S-32 DISK ***AFTER SERIAL NUMBER 113191***

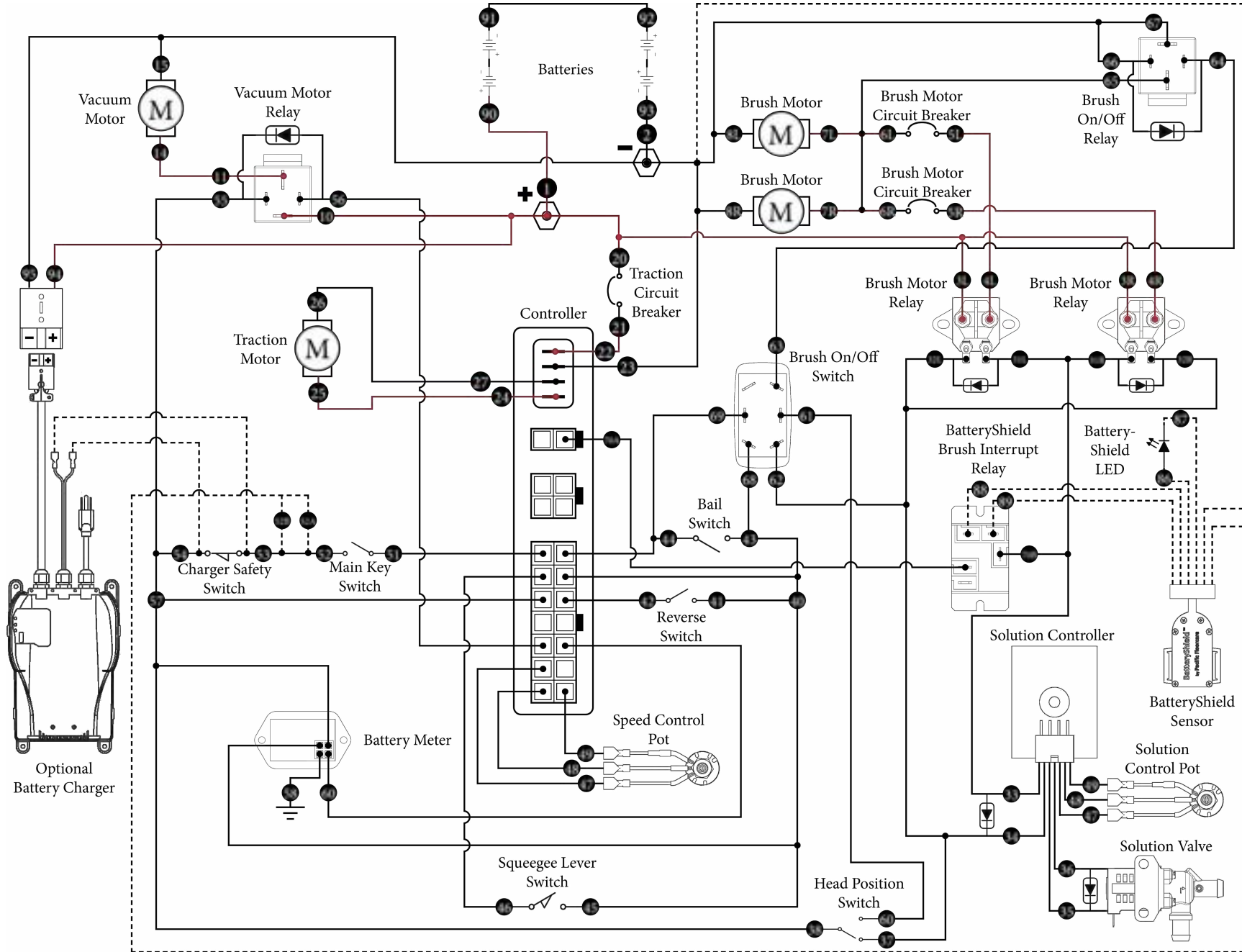

--- Wires represented with dashed lines indicate optional equipment installation

RETURN TO
TABLE OF
CONTENTS

S-28 ORBITAL

*****PRIOR TO SERIAL NUMBER 113191*****

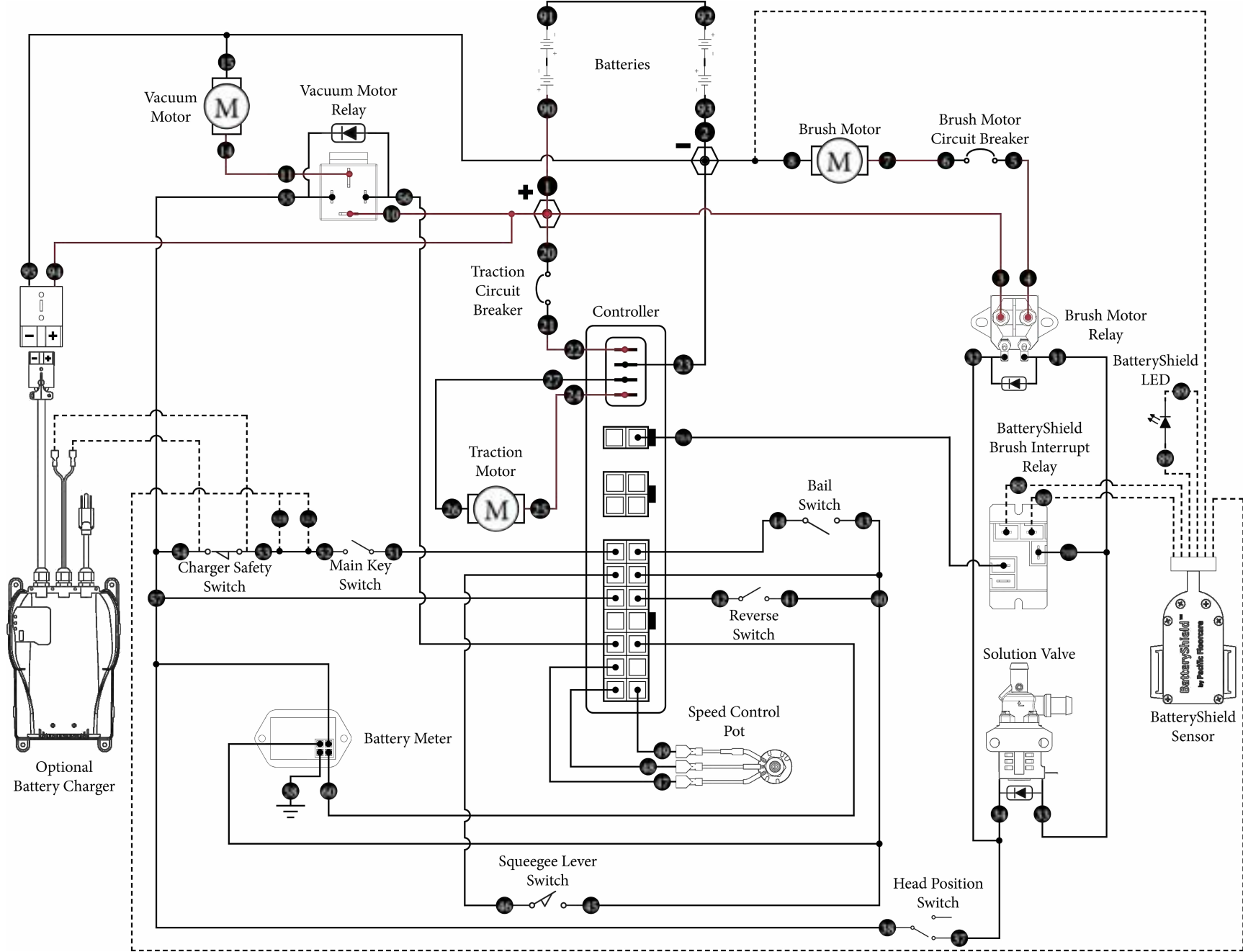

--- Wires represented with dashed lines indicate optional equipment installation

RETURN TO
TABLE OF
CONTENTS

S-28 ORBITAL

AFTER SERIAL NUMBER 113191

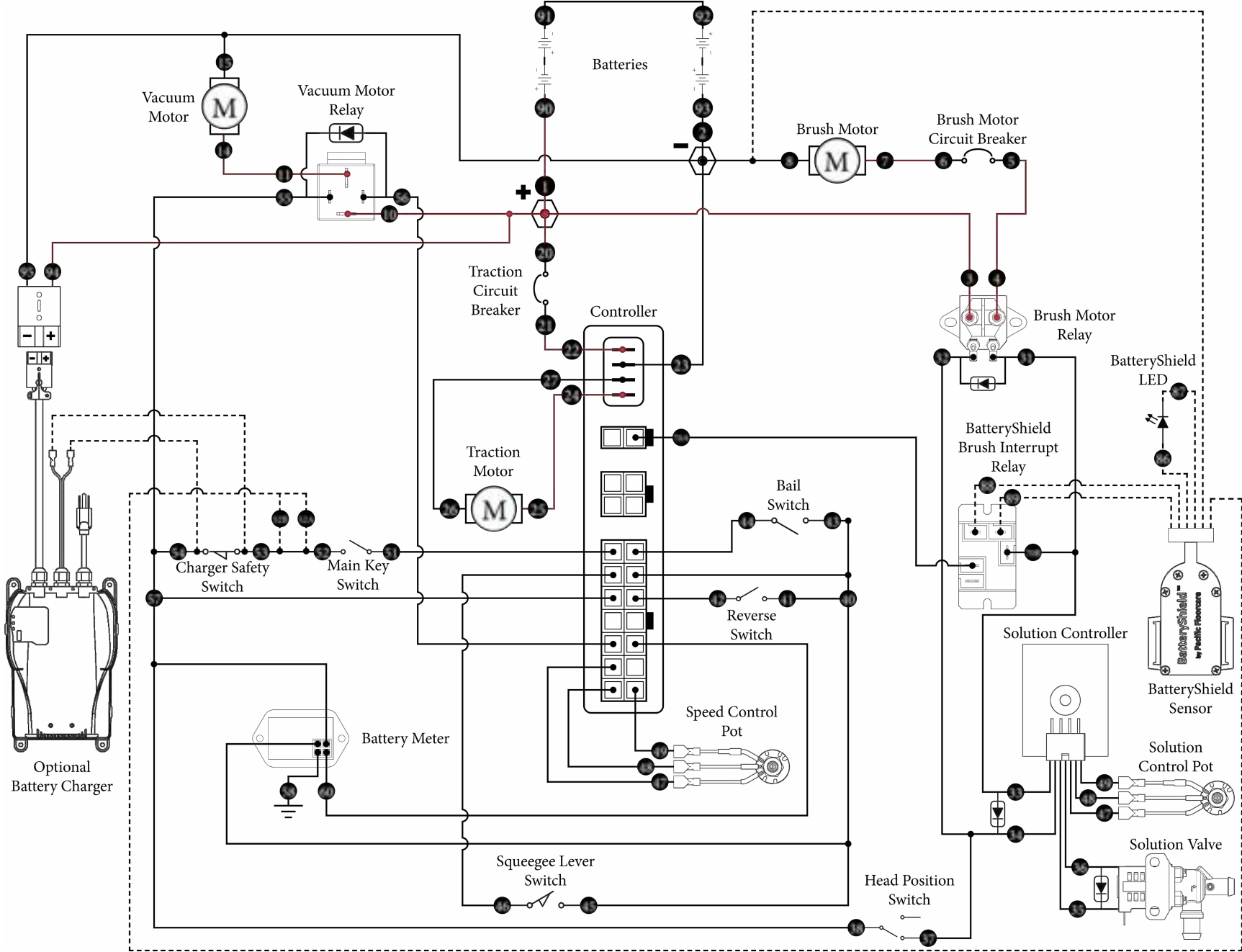

--- Wires represented with dashed lines indicate optional equipment installation

RETURN TO
TABLE OF
CONTENTS

OPTIONAL CHEMICAL INJECTION SYSTEM

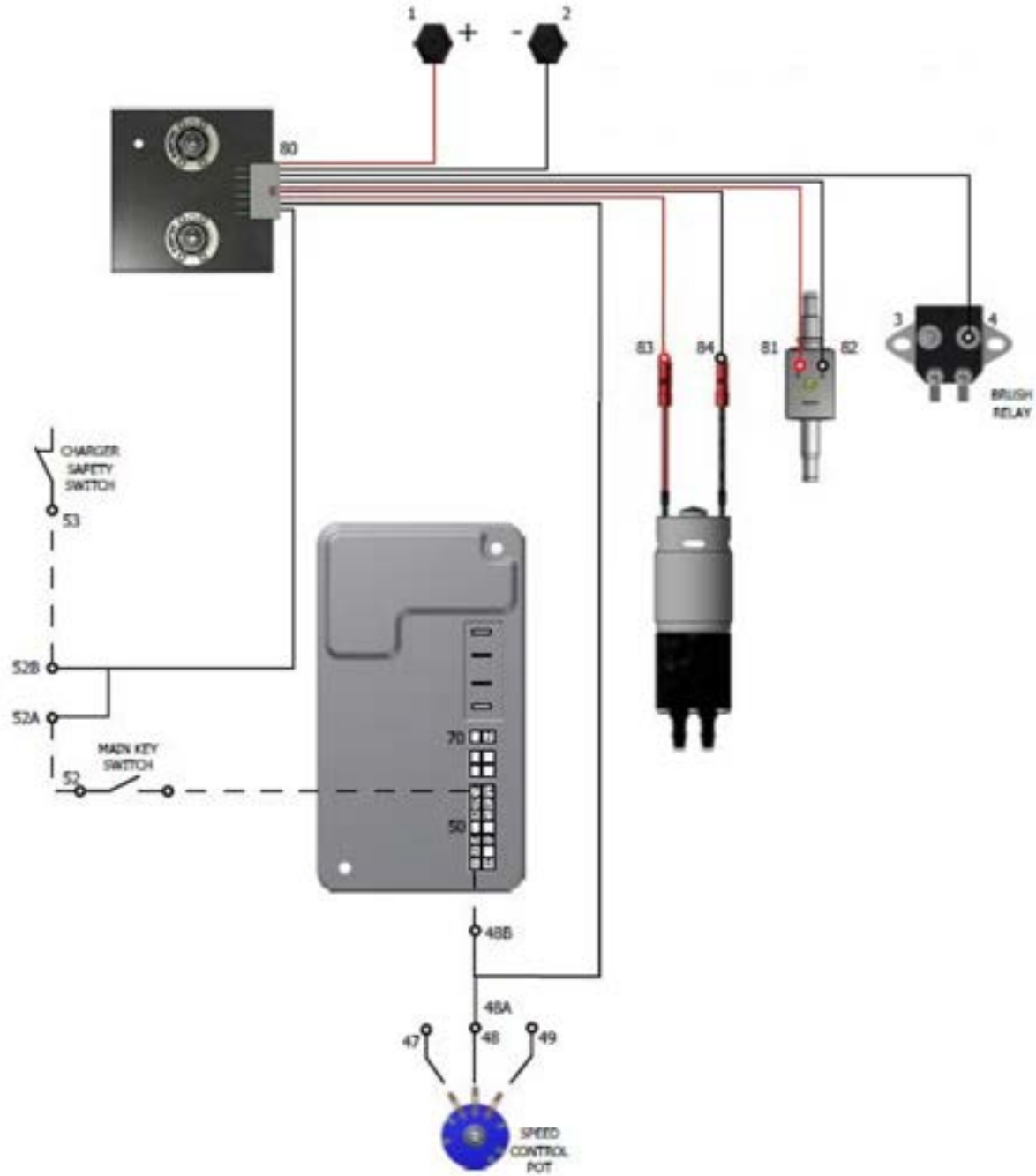

OPTIONAL SCRUBSMART® TELEMETRY SYSTEM

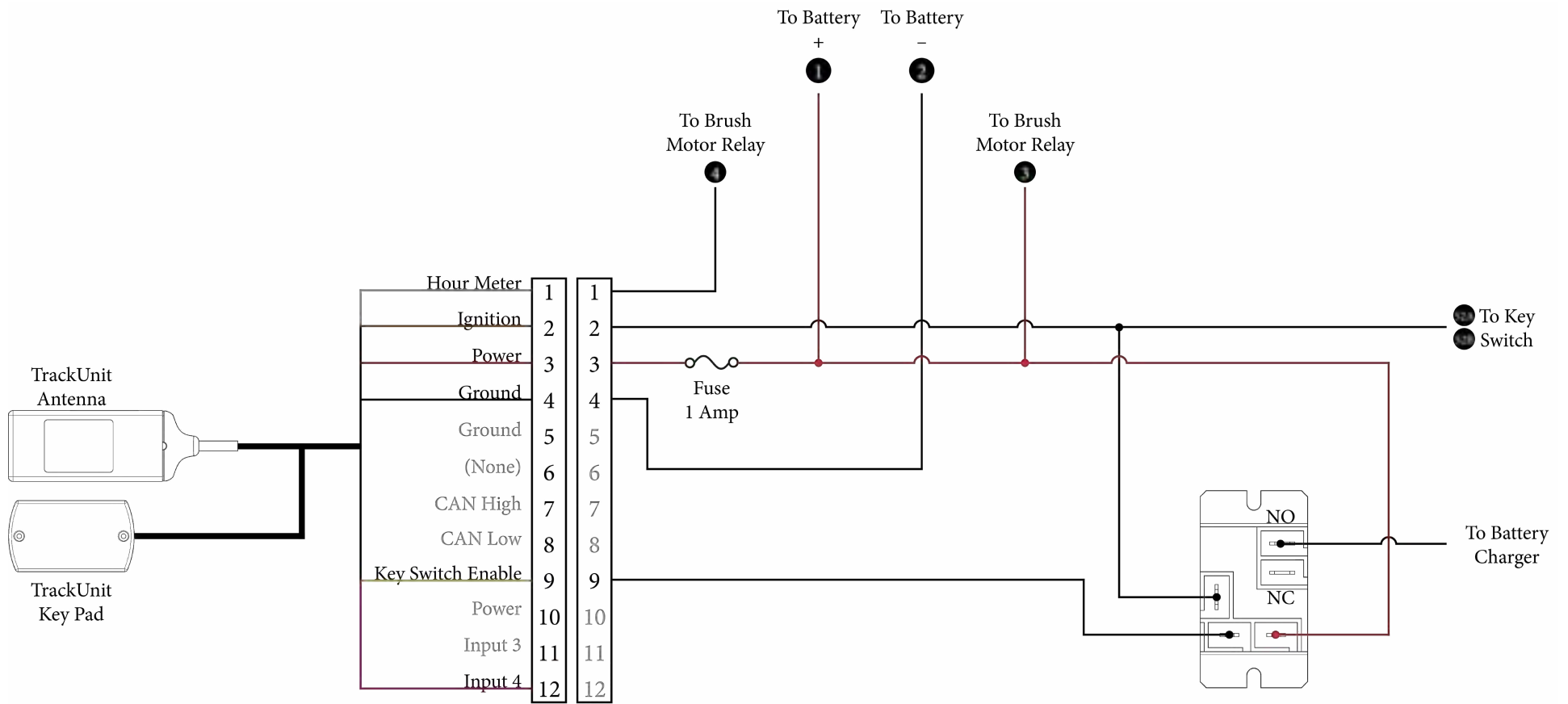

DATE	MAINTENANCE LOG

REVISION	REVISION LOG
2019.10.24	UPDATED BALLOONS FOR THE RECOVERY TANK, PAGE 37.
2020.03.02	MULTIPLE UPDATES, MISC CORRECTIONS AND ADDITIONS.
2020.06.15	UPDATE SQUEEGEE ASSEMBLY IMAGES, PAGES 45-47.
2020.7.29	UPDATE WARRANTY INFORMATION.
2020.10.16	UPDATE WATERING LEAD ACID BATTERIES WITH HYDROLINK, PAGE 9.
2021.1.5	UPDATE BATTERYSHIELD WARRANTY POLICY
2021.2.2	UPDATE 28" DISK AND 32" DISK PARTS DIAGRAMS
2021.3.30	UPDATE PART DESCRIPTION FOR 855204, PAGE 53.
2021.3.31	UPDATE PART NUMBERS, PAGES 55, 57 & 61. REMOVED WARRANTY INFORMATION.
2021.5.25	CORRECTED TYPO, PAGE 4
2021.6.1	UPDATE 28" DISK AND 32" DISK PARTS DIAGRAMS
2021.9.9	UPDATE RECOVERY TANK SYSTEM PARTS DIAGRAMS
2022.3.16	ADDED NOTES, PGS. 47, 48, & 49
2022.6.28	UPDATED HEAD LIFT DIAGRAMS & TABLE, PAGE 45.
2023.5.25	UPDATE PGS. 33-34, 37, 52 & 54. UPDATE ALL ELECTRICAL DIAGRAMS

PAGE INTENTIONALLY BLANK



PACIFIC[®]
F L O O R C A R E

PURPOSE BUILT.[®]

www.pacificfloorcare.com