



**PACIFIC**<sup>®</sup>  
F L O O R C A R E

**WDV-18**

# **18 GALLON WET/DRY VACUUM PARTS & OPERATING MANUAL**



Thank you for purchasing a Pacific Floorcare product. Carefully inspect all components for freight damage. If such damage is discovered, file a “CONCEALED DAMAGE REPORT” immediately with the delivering carrier.

Read this manual carefully and keep it near the machine, protected from liquids and other damaging substances. Failure to follow the instructions may result in injury or damage to equipment and property.

The contents of this manual are based on the latest product information available at the time of publication. Pacific Floorcare reserves the right to make changes or improvements without being obliged to apply changes to the machines previously sold.

New manuals can be downloaded from: [www.pacificfloorcare.com/manuals](http://www.pacificfloorcare.com/manuals)

# 18 GAL. WET/DRY VACUUM SPECIFICATIONS

Features	Specification	Units	
<b>Overall Machine</b>			
Weight		69	lbs.
Dimensions	Width at body	18	In.
	Width at Squeegee	24	In.
	Length	28	In.
	Height	38	In.
Noise Level		79	dBA
<b>Wheels</b>			
Dimension	Rear Wheels	10	In.
	Front Casters	3.5	In.
<b>Recovery Tank</b>			
Capacity		18	Gal.
Draining	Drain Hose	1.5	In.
<b>Vacuum</b>			
Vacuum	Air flow	94	cfm
	Vacuum Lift	90	In. H2O
<b>Squeegee</b>			
Edges	(2) usable edges per blade		
	Blade change with no tools		
Break-away	Break-away with impact		
<b>Operator Controls</b>			
Handle	Height off the floor	38.0	In.
	Diameter	1.5	In.
QR Codes	Machine Manual		
<b>Power</b>			
Voltage		120	VAC
Cord	Yellow 16/3 cord	50	Ft.
	Molded cord retainer		
<b>Accessory Kit</b>			
Includes	Dry filter, 10' hose, 2 cuffs, 2-piece aluminum S-wand, crevice tool, dusting brush, upholstery tool, squeegee tool, floor brush, and hard floor tool		

# TABLE OF CONTENTS

<b>SAFETY INFORMATION .....</b>	<b>1</b>
GROUNDING INSTRUCTIONS .....	1
USING EXTENSION CORDS.....	2
LIFTING AND TRANSPORTATION.....	2
PREPARATION.....	2
<b>SQUEEGEE ASSEMBLY .....</b>	<b>3</b>
SQUEEGEE HEAD REMOVAL AND INSTALLATION.....	3
SQUEEGEE BLADE REPLACEMENT .....	3
SQUEEGEE LIFT .....	4
<b>MACHINE DRAINING .....</b>	<b>5</b>
<b>COVER ASSEMBLY.....</b>	<b>6</b>
<b>DRY FILTER.....</b>	<b>7</b>
<b>WIRING DIAGRAM.....</b>	<b>7</b>
<b>MAINTENANCE.....</b>	<b>8</b>
<b>TROUBLESHOOTING .....</b>	<b>8</b>
<b>PARTS DIAGRAMS.....</b>	<b>9</b>
COVER ASSEMBLY .....	9
TANK ASSEMBLY .....	11
SQUEEGEE ASSEMBLY .....	15
SQUEEGEE LINK ASSEMBLY.....	16
<b>OPTIONAL ACCESSORIES KIT .....</b>	<b>17</b>



# SAFETY INFORMATION



## SAVE THESE INSTRUCTIONS

This machine is intended for commercial use.

When using an electrical appliance, basic precautions should always be followed, including the following:

### READ ALL INSTRUCTIONS BEFORE USING THIS VACUUM CLEANER

**WARNING:** To reduce the risk of fire, electrical shock, or injury:

- Do not leave appliance when plugged in. Unplug from the outlet when not in use and before servicing.
- Do not use outdoors.
- Do not allow to be used as a toy. Close attention is necessary when used in the presence of children.
- Use only as described in this manual. Use only manufacturer's recommended attachments.
- Do not use with damaged cord or plug. If appliance is not working as it should, has been dropped, damaged, left outdoors, or dropped into water, return it to a service center.
- Do not pull or carry by cord, use cord as a handle, close a door on cord, or pull cord around sharp edges or corners. Do not run appliance over cord. Keep cord away from heated surfaces.
- Do not unplug by pulling on cord. To unplug, grasp the plug, not the cord.
- Do not handle plug or appliance with wet hands.
- Do not put any object into openings. Do not use with any opening blocked; keep free of dust, lint, hair, and anything that may reduce airflow.
- Keep hair, loose clothing, fingers, and all parts of body away from openings and moving parts.
- Turn off all controls before unplugging.
- Use extra care when cleaning stairs.
- Do not use to pick up flammable or combustible liquids, such as gasoline, or use in areas where they may be present.
- Do not use without dust bag and/or filters in place.
- Do not pick up anything that is burning or smoking, such as cigarettes, matches, or hot ashes.
- Connect to a properly grounded outlet only. See Grounding Instructions.

## GROUNDING INSTRUCTIONS

This appliance must be grounded. If it should malfunction or break down, grounding provides a path of least resistance for electric current to reduce the risk of electric shock. This appliance is equipped with a cord having an equipment-grounding conductor and grounding plug. The plug must be inserted into an appropriate outlet that is properly installed and grounded in accordance with all local codes and ordinances.

**WARNING:** Improper connection of the equipment-grounding conductor can result in a risk of electric shock. Check with a qualified electrician or service person if you are in doubt as to whether the outlet is properly grounded. Do not modify the plug provided with the appliance. If it will not fit into the outlet, have a proper outlet installed by a qualified electrician.

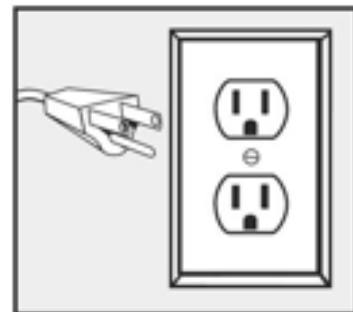

This appliance is for use on a nominal 120-volt circuit and has a grounding attachment plug that looks like the plug illustrated. Make sure that the appliance is connected to an outlet having the same configuration as the plug. No adapter should be used with this appliance.

## USING EXTENSION CORDS

The machine comes standard with a 50 foot, 16 gauge, 3 conductor cord (50' 16/3 AWG). Do not use an extension cord in conjunction with the cord provided with the machine. Replacement cords must meet or exceed the specification of the original cord.

**WARNING:** Do not use an extension cord that provides a loose connection. A loose connection may result in overheating, fire, and increases the risk of a burning.

Maintain Appliance With Care – Inspect extension cords periodically and replace if damaged. When not in use, wrap the cord carefully around the handle as shown below.



## LIFTING AND TRANSPORTATION

**CAUTION:** Two person lift. Never attempt to lift the machine alone.



- Unplug the cord and wrap it securely around the handle.
- Secure the machine with straps during transport in a vehicle or trailer to prevent damage.

## PREPARATION

- Verify the facility and the machine have compatible voltage prior to use (see Safety Instructions).
- Inspect the machine for loose or damaged components.

# SQUEEGEE ASSEMBLY

## SQUEEGEE HEAD REMOVAL AND INSTALLATION

Use the two black center knobs (rotate counter-clockwise to loosen, rotate clockwise to tighten) to remove and install the squeegee assembly from the machine.

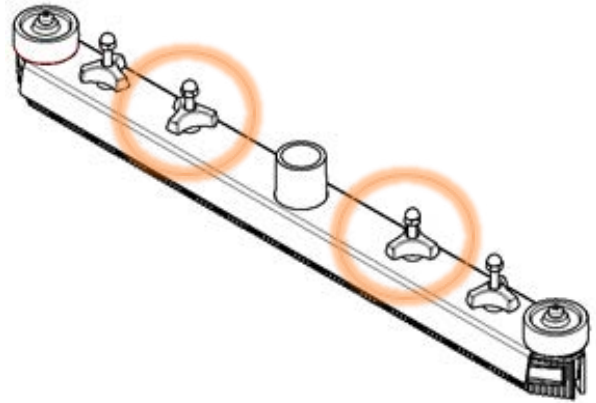

## SQUEEGEE BLADE REPLACEMENT

**NOTE:** The Squeegee Blades can be used twice by flipping them over to use the previously un-used edge. Installation is the reverse of installation.

- Loosen all (4) knobs until the stop rotating.
- Slide the outer Squeegee Assembly housing up the posts.
- Remove the Squeegee Blades.

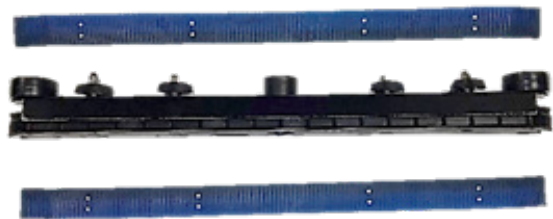
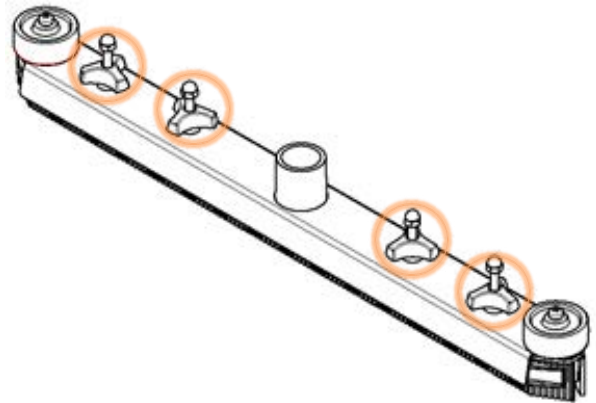

## SQUEEGEE LIFT

- Move the foot lever forward and allow the Squeegee Assembly to lower to the working position.



- Press the foot lever down and back to lock the Squeegee Assembly to the upper position.

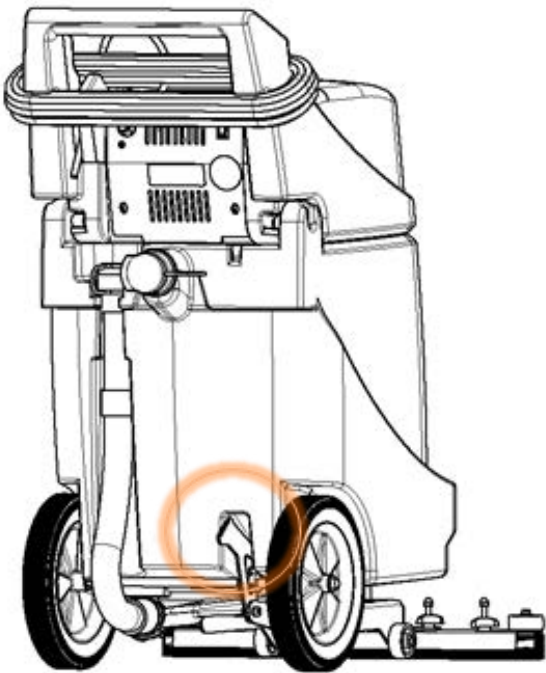
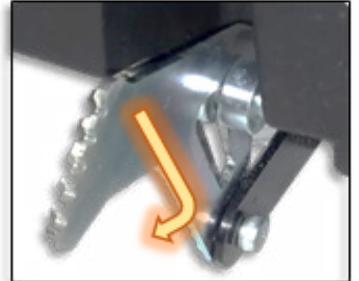

# MACHINE DRAINING

**NOTE:** The vacuum must be turned off prior to draining the machine.

## Hose Drain:

1. Back the machine up to the drain.
2. Lift the drain hose from the holster.
3. Remove the drain cap.
4. Lay the hose into the drain.
5. Replace the cap when finished.



## Spout Drain:

1. Remove the cover assembly.
2. Back the tank up to the drain location.
3. Remove the Drain Spout Cap and secure it in the recessed area to the right of the spout to prevent it from interfering with the drain area.
4. Using the two-person lift method, grab the handle at the base of the tank and tilt backwards to begin draining the tank.
5. Follow all of your company's safety policies and standards when lifting and moving the machine.

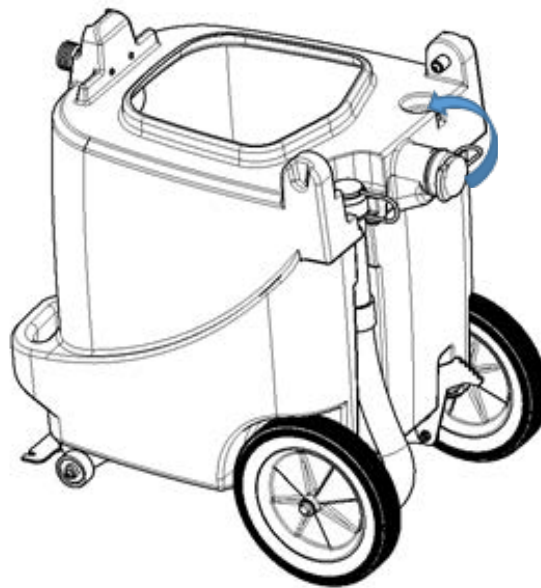



# COVER ASSEMBLY

## Open:

To open the cover assembly, release the latch on the front of the machine and lift the cover backwards until it stops.

## Close:

Lower the cover, verifying it is properly seated on the Tank. Secure the latch to the catch on the Tank.

## Removal:

1. Secure the electrical cord.
2. Release the latch on the front of the machine and lift the cover backwards.
3. Lift the cover off of the Tank.

## Installation:

**NOTE:** Make sure the drain spout cap is not stored in the recession on top of the tank. It will prevent the cover from seating to the tank.

1. With the cover angled backwards, align the slots on the handle with the mounting pins on the tank.
2. Slide the cover onto the pins and lower the cover forward until it rests on the tank.
3. Verify the lid is properly seated on the tank.
4. Secure the latch on the front of the cover to the catch on the Tank.

## Ball Float:

The ball float threads on to the cover assembly and is reinforced by a clamp. The clamp may remain on the ball float during removal and installation.

Remove and clean the ball float frequently to prevent buildup.

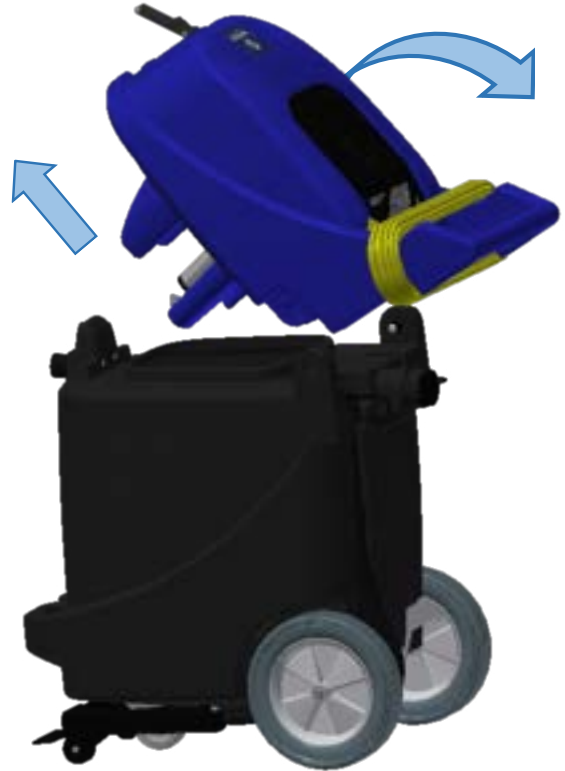

# DRY FILTER

The optional dry filter is installed over the ball float. The dry filter must be removed for wet recovery.

**NOTE:** Once the mount bracket is installed, it does not need to be removed.

## Installation:

1. Use the (2) screws and lock washers to install the mount bracket as shown.
2. Slide the filter element over the bracket.
3. Install the filter retaining cap and secure with the wingnut.

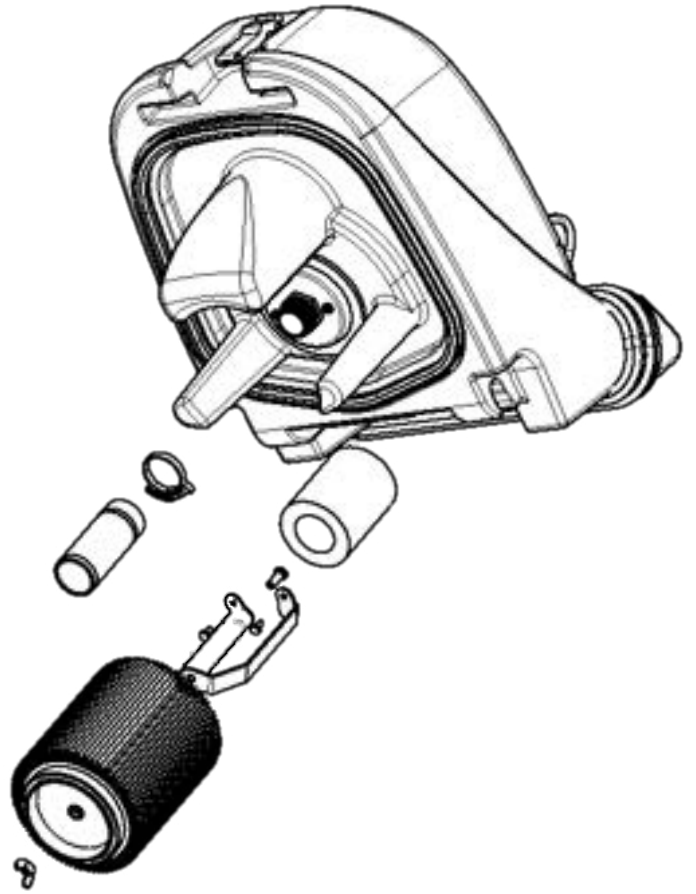

# WIRING DIAGRAM

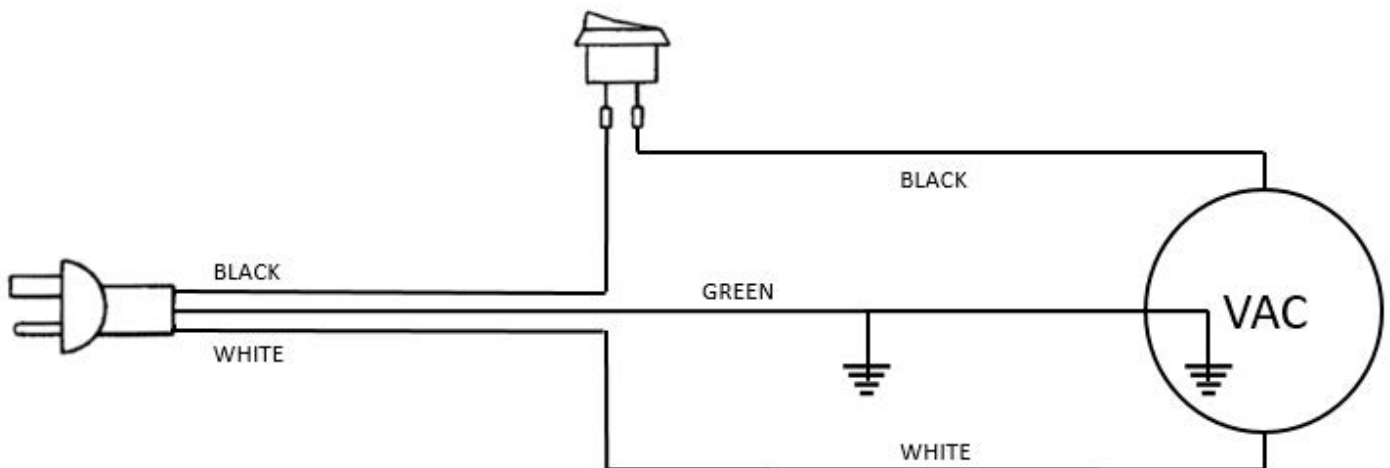

# MAINTENANCE

**NOTE:** Read all safety instructions prior to performing maintenance.

**WARNING:** Always unplug the cord from the power source prior to performing any service, maintenance, or inspection of the machine.

1. After each use:
  - Inspect cords, switches, casters, and wheels for wear or damage.
  - Clean vacuum motor ventilation louvers.
2. After each wet use:
  - Remove the squeegee assembly and clean the blade retainer and opening.
  - Inspect the squeegee blades for wear and damage.
  - Verify the float shut-off moves freely. If the tank overfills or shows signs of foaming, use a de-foaming agent.
  - Inspect hoses, caps, and recovery tank gasket for leaks, cuts, or damage.
  - Rinse the recovery tank and clean any residue or heavy solids left behind.
3. When using the dry filter, remove and blow out the filter element weekly.

# TROUBLESHOOTING

ISSUE	POTENTIAL CAUSE	SOLUTION
Vacuum will not turn on	Faulty power supply	Contact facility maintenance
	Faulty power cord	Replace cord
	Internal electrical problem	Contact service technician
	Faulty On/Off switch	Contact service technician
	Faulty vacuum motor	Contact service technician
Poor vacuum pickup	Ball float is stuck	Manually reset ball float
	Cover gasket is dirty or damaged	Clean and inspect/replace gasket
	Drain cap is not installed	Install drain cap
	Hose is obstructed	Clear all debris from hoses
	Squeegee assembly is dirty	Clean squeegee assembly
	Squeegee blades are worn or damaged	Replace squeegee blades

# PARTS DIAGRAMS

## COVER ASSEMBLY

ITEM	QTY	PART NUMBER	DESCRIPTION
1	1	692301	COVER TANK WDV
2	1	692302	COVER MOTOR VACUUM
3	4	962263	SCREW, BUTT, SOCK, .25-20X.62, SS BO
4	1	695201	MOTOR VACUUM 120VAC
5	1	603473	GASKET 198395
6	1	696101	PLATE MTG MOTOR VACUUM
7	1	911089	SWITCH, ROCKER, 20A 125 VAC
8	1	693301	FOAM NOISE MOTOR COOLING
9	1	693302	FOAM NOISE REAR
10	2	962063	SCREW, PAN, #8-32 X .38
11	2	980026	WASHER, LOCK, #8 INT TOOTH
12	1	223370	FLOAT, SHUTOFF
13	1	693303	FITTING COUPLING 1.25 NPT
14	1	698501	STRIP FOAM GASKET
15	1	505187	LABEL, SERIAL NUMBER
16	1	853401	GASKET, COVER, PRESS-IN
17	1	908136	CORD EXTENSION 50' YELLOW
18	8	964224	SCREW, PAN, #10 X .5, SELF TAPPING
19	1	694501	HARNES 2-WIRE WDV
20	1	908137	CORD PIGTAIL WDV
21	1	695101	LABEL WARNING TRI-LINGUAL
22	2	W124D	WASHER LOCK INT #10
23	2	920013	NUT, #10-32, ZINC
24	1	962363	SCREW, PAN, #10-32 X .50, SS
25	1	691102	BUSHING STRAIN RELIEF CORD
26	1	692002	CLAMP HOSE PLASTIC 1.69-1.81 DIA
27	1	695102	CLAMP OVER-CENTER RUBBER
28	1	505197	LABEL, PACIFIC, 3 INCH
29	1	693305	FILTER KNOCK DOWN FOAM

# PARTS DIAGRAMS

## COVER ASSEMBLY

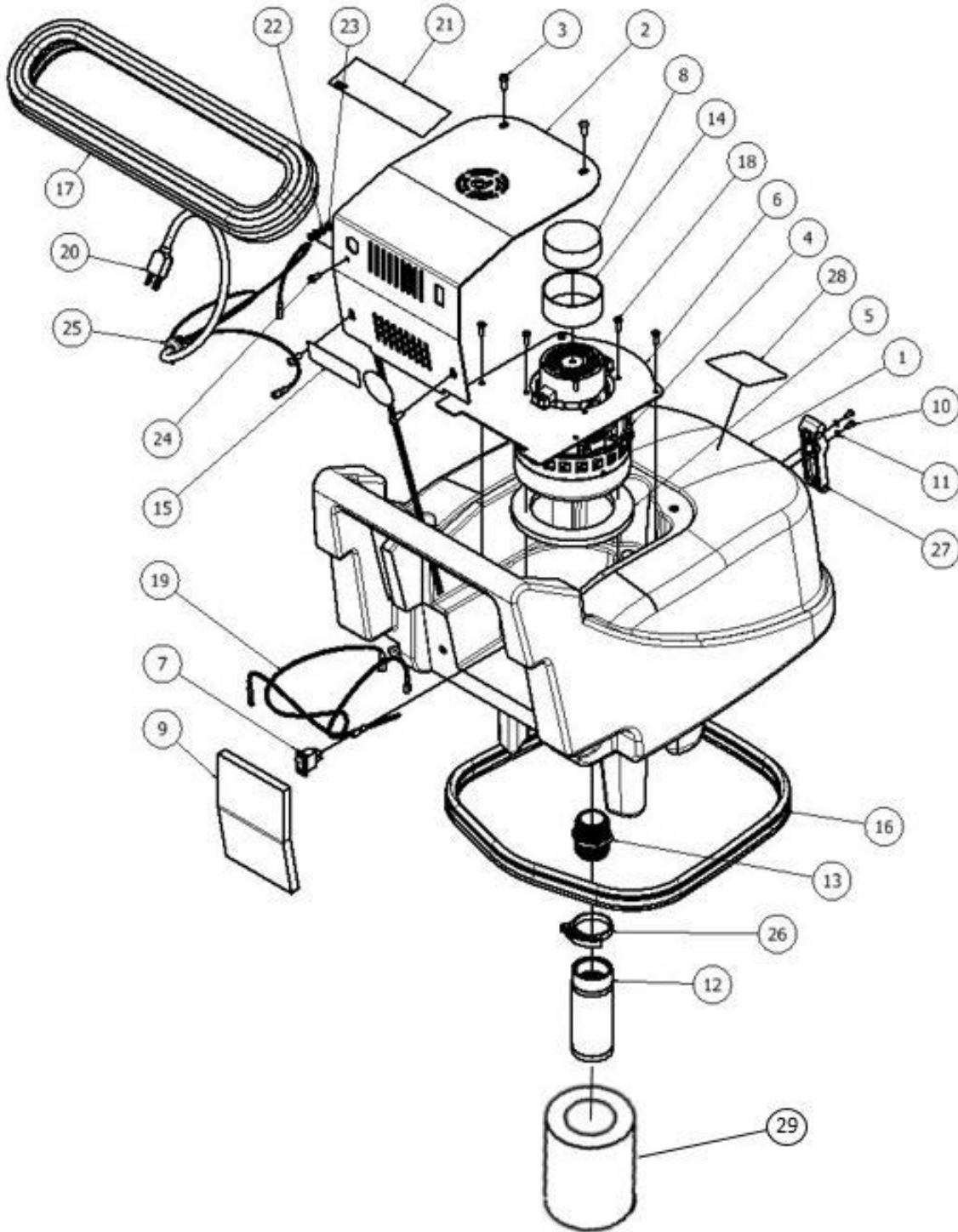

# PARTS DIAGRAMS

## TANK ASSEMBLY

Prior To Serial Number: 120540

ITEM	QTY	PART NUMBER	DESCRIPTION
1	1	698601	TANK RECOVERY WDV
2	1	694101	HOSE DRAIN WDV WITH CAP
3	1	692002	CLAMP HOSE PLASTIC 1.69-1.81 DIA
4	1	696801	PLUG DRAIN HOLE 2 INCH
5	4	W189D	SCREW, HEX, 1/4-20 X .75, SS, PATCH
6	4	980002	WASHER, LOCK, SPLIT, .25
7	4	W104D	WASHER, FLAT, .25
8	1	853308	FITTING, MODIFIED
9	1	695102	CLAMP OVER-CENTER RUBBER KEEPER ONLY
10	2	962063	SCREW, PAN, #8-32 X .38
11	2	980026	WASHER, LOCK, #8 INT TOOTH
12	2	698201	SPACER NYLON
13	2	962464	SCREW, BUTTON, .31-18X1.25, ZINC
14	2	980094	WASHER, SPLIT LOCK, .31, SS
15	2	229750	WHEEL- 10X1.75 GREY
16	1	697701	SHAFT WHEEL WDV
17	4	509820	WASHER FIBER .50INCH
18	2	S482P	SNAP AXLE CAP .50INCH
19	2	542402	COLLAR, CLAMP, .50INCH
20	2	692001	CLAMP AXLE .50 INCH
21	4	962363	SCREW, PAN, #10-32 X .50, SS
22	4	980022	WASHER, LOCK, SPLIT, #10
23	1	692701	DEFLECTOR WATER WDV
24	2	W401D	WASHER, FLAT, #10
25	2	930023	RIVET .188 DIA, .50-.62 GRIP
26	1	699701	CASTER 3.5 INCH TOP PLATE

AVAILABLE REINFORCED WHEEL CONVERSION KIT - #695009		
QTY	PART NUMBER	DESCRIPTION
2	692001	CLAMP AXLE .50 INCH
2	259705	WHEEL 10 X 1.75 .5 HUB
2	218201	SPACER NYLON 0.5 ID 1.0 X 0.50

# PARTS DIAGRAMS

## TANK ASSEMBLY

Prior To Serial Number: 120540

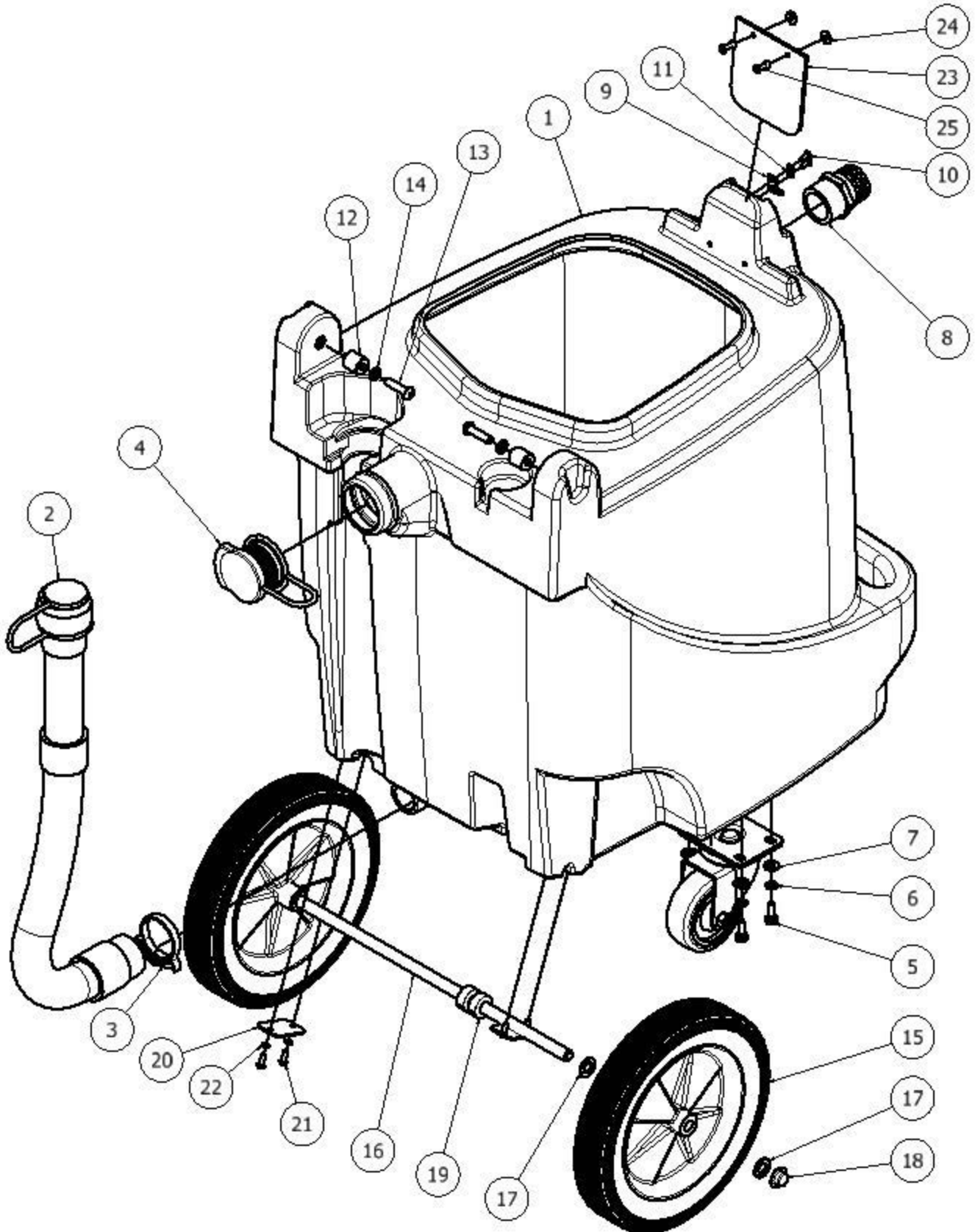

# PARTS DIAGRAMS

## TANK ASSEMBLY

After Serial Number: 120540

ITEM	QTY	PART NUMBER	DESCRIPTION
1	1	698601	TANK RECOVERY WDV
2	1	694101	HOSE DRAIN WDV WITH CAP
3	1	692002	CLAMP HOSE PLASTIC 1.69-1.81 DIA
4	1	696801	PLUG DRAIN HOLE 2 INCH
5	4	W189D	SCREW, HEX, 1/4-20 X .75, SS, PATCH
6	4	980002	WASHER, LOCK, SPLIT, .25
7	4	W104D	WASHER, FLAT, .25
8	1	853308	FITTING, MODIFIED
9	1	695102	CLAMP OVER-CENTER RUBBER KEEPER ONLY
10	2	962063	SCREW, PAN, #8-32 X .38
11	2	980026	WASHER, LOCK, #8 INT TOOTH
12	2	698201	SPACER NYLON
13	2	962464	SCREW, BUTTON, .31-18X1.25, ZINC
14	2	980094	WASHER, SPLIT LOCK, .31, SS
15	1	697701	SHAFT WHEEL WDV
16	4	509820	WASHER FIBER .50INCH
17	2	S482P	SNAP AXLE CAP .50INCH
18	2	542402	COLLAR, CLAMP, .50INCH
19	2	692001	CLAMP AXLE .50 INCH
20	4	962363	SCREW, PAN, #10-32 X .50, SS
21	4	980022	WASHER, LOCK, SPLIT, #10
22	1	692701	DEFLECTOR WATER WDV
23	2	W401D	WASHER, FLAT, #10
24	2	930023	RIVET .188 DIA, .50-.62 GRIP
25	1	699701	CASTER 3.5 INCH TOP PLATE
26	2	259705	WHEEL 10 X 1.75 .5 HUB
27	2	218201	SPACER NYLON 0.5 ID 1.0 X 0.50



# PARTS DIAGRAMS

## TANK ASSEMBLY

After Serial Number: 120540

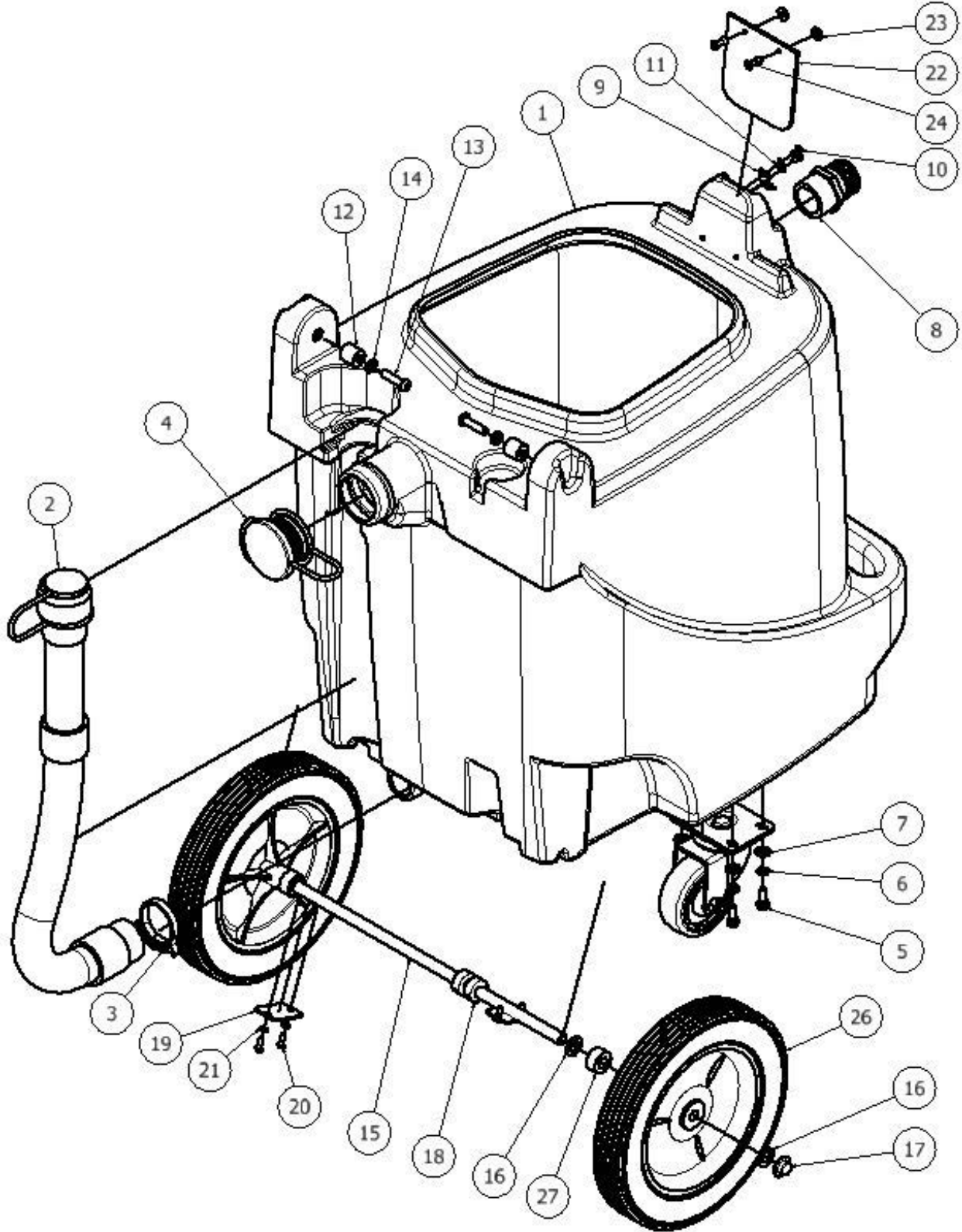

# PARTS DIAGRAMS

## SQUEEGEE ASSEMBLY

ITEM	QTY	PART NUMBER	DESCRIPTION
1	1	693202	FRAME SQUEEGEE WDV
2	1	697201	RETAINER BLADE SQUEEGEE
3	2	690701	BLADE SQUEEGEE 2-EDGE WDV
4	1	694102	HOSE SQUEEGEE WDV
5	2	695001	KNOB RETENTION SQUEEGEE
6	2	695005	KNOB RETENTION BLADE BLUE
7	4	920701	NUT ACORN .25-20 1-PIECE BLK
8	4	962478	SCREW 14-20X2.25 HEX ZINC FULL THRD
9	6	920011	NUT, NYLOCK, 1/4-20, ZINC
10	4	W104D	WASHER, FLAT, .25
11	2	699702	WHEEL 2 INCH DIA .31 ID
12	2	962290	SCREW SHLDR .31"DIA. X 1.0"L X .25-20

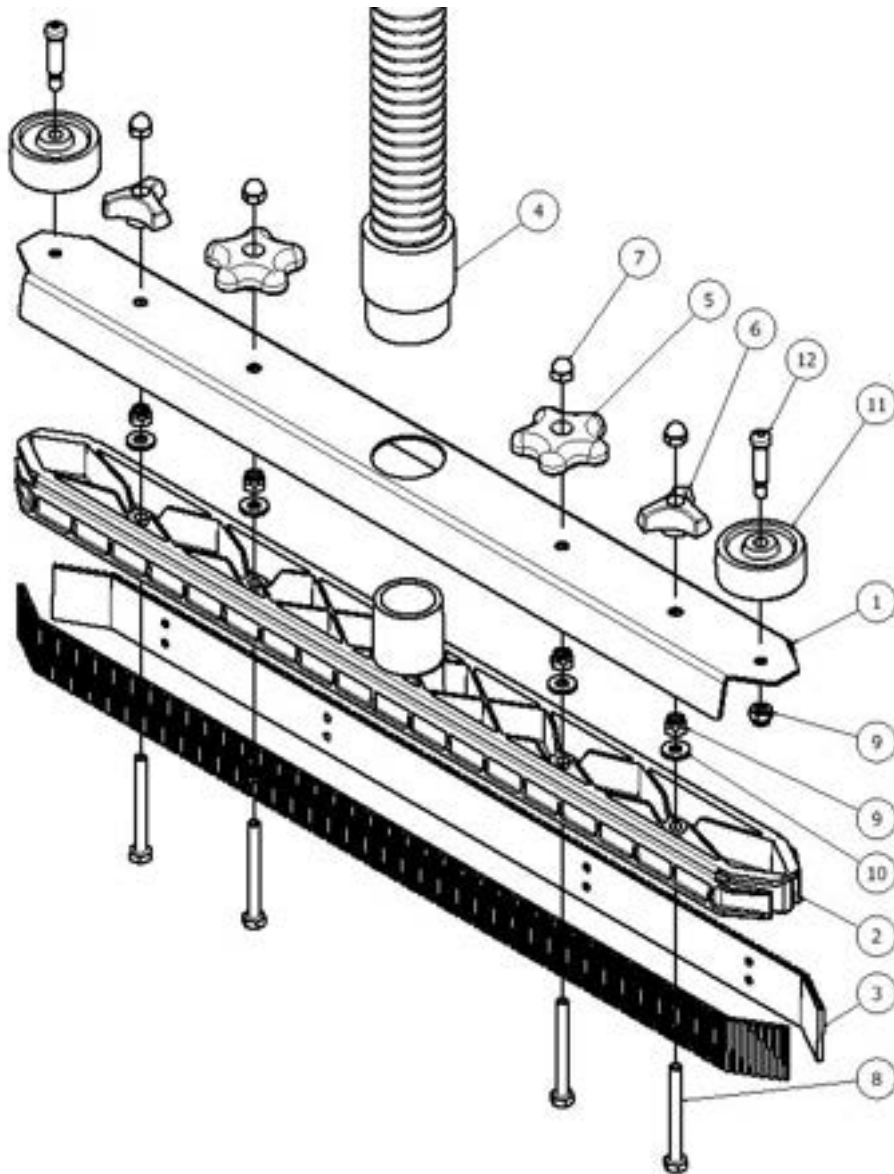

# PARTS DIAGRAMS

## SQUEEGEE LINK ASSEMBLY

ITEM	QTY	PART NUMBER	DESCRIPTION
1	1	693201	FRAME LIFT SQUEEGEE
2	1	690802	BRACKET LIFT SQUEEGEE
3	3	962238	SCREW SHLDR .38"DIA. X .25"L X .31-18
4	3	691101	BUSHING SPLIT .38 INCH
5	1	920036	NUT, NYLOCK, 5/16-18, SS
6	2	699702	WHEEL 2 INCH DIA .31 ID
7	2	920011	NUT, NYLOCK, 1/4-20, ZINC
8	2	962290	SCREW SHLDR .31"DIA. X 1.0"L X .25-20

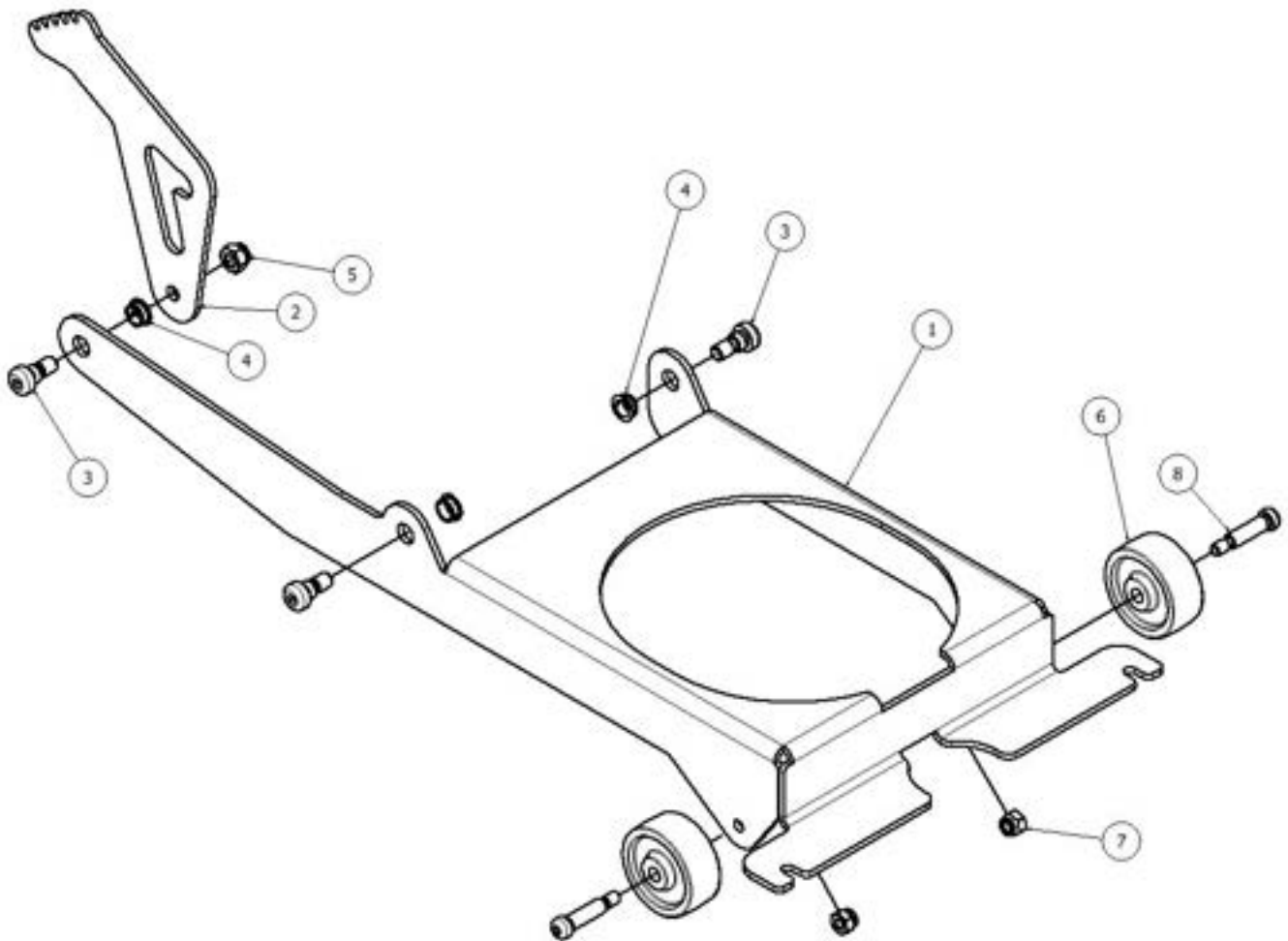

# OPTIONAL ACCESSORIES KIT

ITEM	QTY	PART NUMBER	DESCRIPTION
	1	695004	KIT, ACCESSORIES
1	2	980002	LOCK WASHER
2	2	W169D	1/4-20 HEX CAP SCREW
3	1	690801	BRACKET, FILTER RETAINER
4	1	693304	FILTER ELEMENT (W/ UPPER & LWR SEALS)
5	1	691501	CAP, FILTER RETAINER
6	1	920700	NUT, WING .38-16
7	1	695002	TOOL, HARD FLOOR
8	1		TOOL, UPHOLSTERY
9	1		TOOL SQUEEGEE
10	1		BRUSH FLOOR
11	1		TOOL, CREVICE
12	1		BRUSH, DUST
13	1		HOSE, 10 FT
14	2		CUFF, HOSE
15	1		WAND, S-SHAPED (2 PIECE)

# OPTIONAL ACCESSORIES KIT

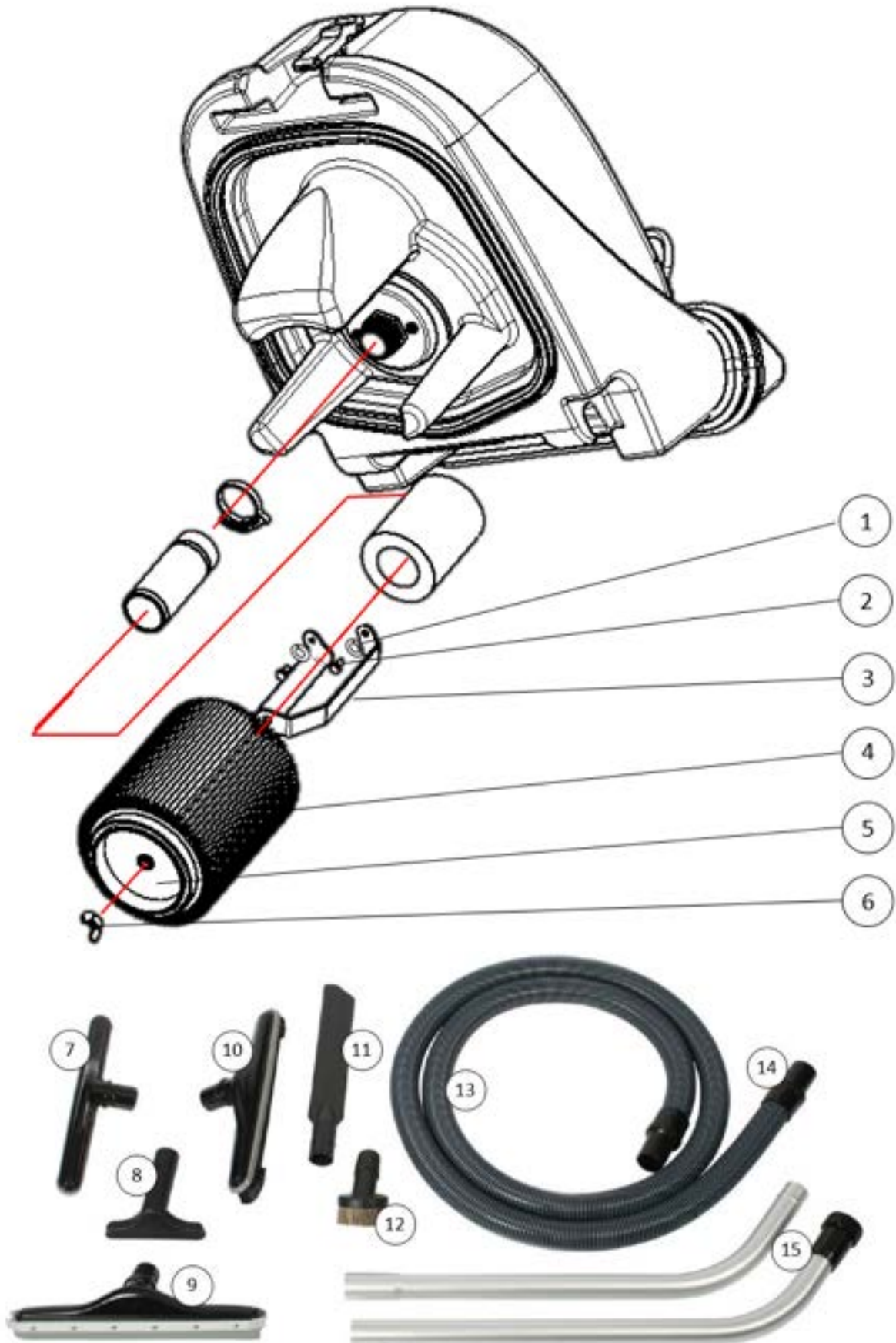

**PAGE INTENTIONALLY BLANK**

REVISION	REVISION LOG
2020.7.29	DOCUMENTED NEW WHEELS, ADDED PGS. 13-14
2021.3.5	UPDATE WARRANTY POLICY
2021.4.15	REMOVED WARRANTY POLICY



**PACIFIC**<sup>®</sup>  
F L O O R C A R E

**PURPOSE BUILT.**<sup>®</sup>

[www.pacificfloorcare.com](http://www.pacificfloorcare.com)